

Wastewater combination air valve

Mod. SWV 3S

SWV 3S air valve guarantees the proper operation of sewage lines allowing the entrance and the discharge of large volumes of air, during pipe draining and filling operations, and the release of air pockets during working conditions.



Technical features and benefits

- Large lower body designed with strongly sloped funnel shaped walls to avoid deposit of grease or other material, and containing four ribs obtained by casting to guide the stainless steel float.
- Upper body containing a casing that protects the air release device against spurts during rapid filling.
- Mobile block including a large AISI 316 stainless steel float, placed on the lower body, and connected through a stainless steel rod to the air release system.
- Flat obturator in solid polypropylene to avoid deformations and to prevent it from remaining stuck to the gaskets, while other materials have the tendency to do it.
- Drainage valve for chamber control and draining.
- Nozzle and gasket holder wear resistant thanks to gasket compression control.
- Maintenance can be easily performed from the top without removing the air valve from the pipe.
- Evacuation bend in polypropylene standard for DN 50/65 and on request for other DN (through SUB kit).

Applications

- Sewage main transmission lines.
- Treatment plants.
- Irrigation systems in presence of solids/debris in suspension.
- Whenever the technology of air valves for treated water can't be used for the risk of clogging and damages to the internal components.

Operating principle



Discharge of large volumes of air

During the pipe filling it is necessary to discharge air as liquid flows in. The SWV 3S, thanks to an aerodynamic body and deflector, will make sure to avoid premature closures of the mobile block during this phase.

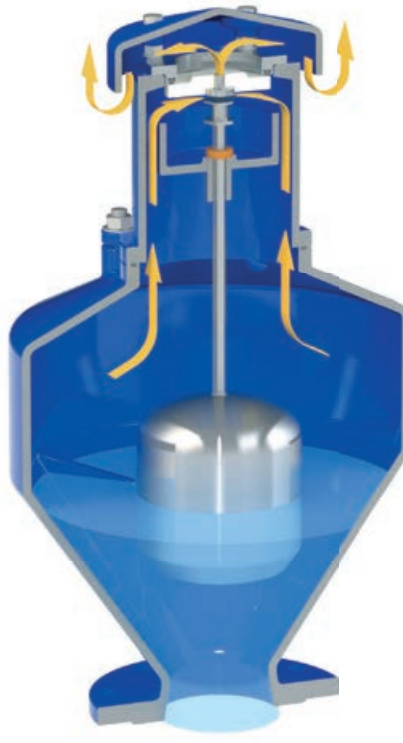

Air release during working conditions

During operation the air produced by the pipeline is accumulated in the upper part. Little by little it is compressed and its volume increases, pushing the liquid level downwards and allowing the air release through the nozzle.



Entrance of large volumes of air

During pipeline draining, or pipe bursts, it is necessary to bring in as much air as the quantity of outflowing liquid. This is to avoid negative pressure and serious damages to the pipeline and the entire system.

Optional



- **Vacuum breaker version Mod. SWV 2S**, to allow the entrance and discharge of large volumes of air only. This model is normally recommended on changes in slope ascending, long ascending segments, and wherever the air release won't be required.



- **Version for submerged applications, SUB series**, standard for DN 50/65, available both for SWV 3S and SWV 2S Models, with elbow for air conveyance. The design sprang from the necessity of having an air valve performing also in case of flood, without the risk of contaminated water entering the pipeline. Another benefit of SUB is to avoid the spray effect, conveying spurts coming from the rapid closure of the air valve.



- **Version for air discharge only EO series** (on request), available both for SWV 3S and SWV 2S models. The most important application of EO is to allow the air valve installation in those locations of the system where HGL may drop below the pipe profile, and to any other node where for project requirements air entrance must be avoided.

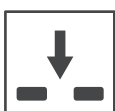

- **Version for air entrance only IO series**, available for vacuum breaker model. The most important application of IO is to allow the air valve installation in those locations of the system where, for project requirements, air discharge and release must be avoided.

Technical data

Air flow performance charts

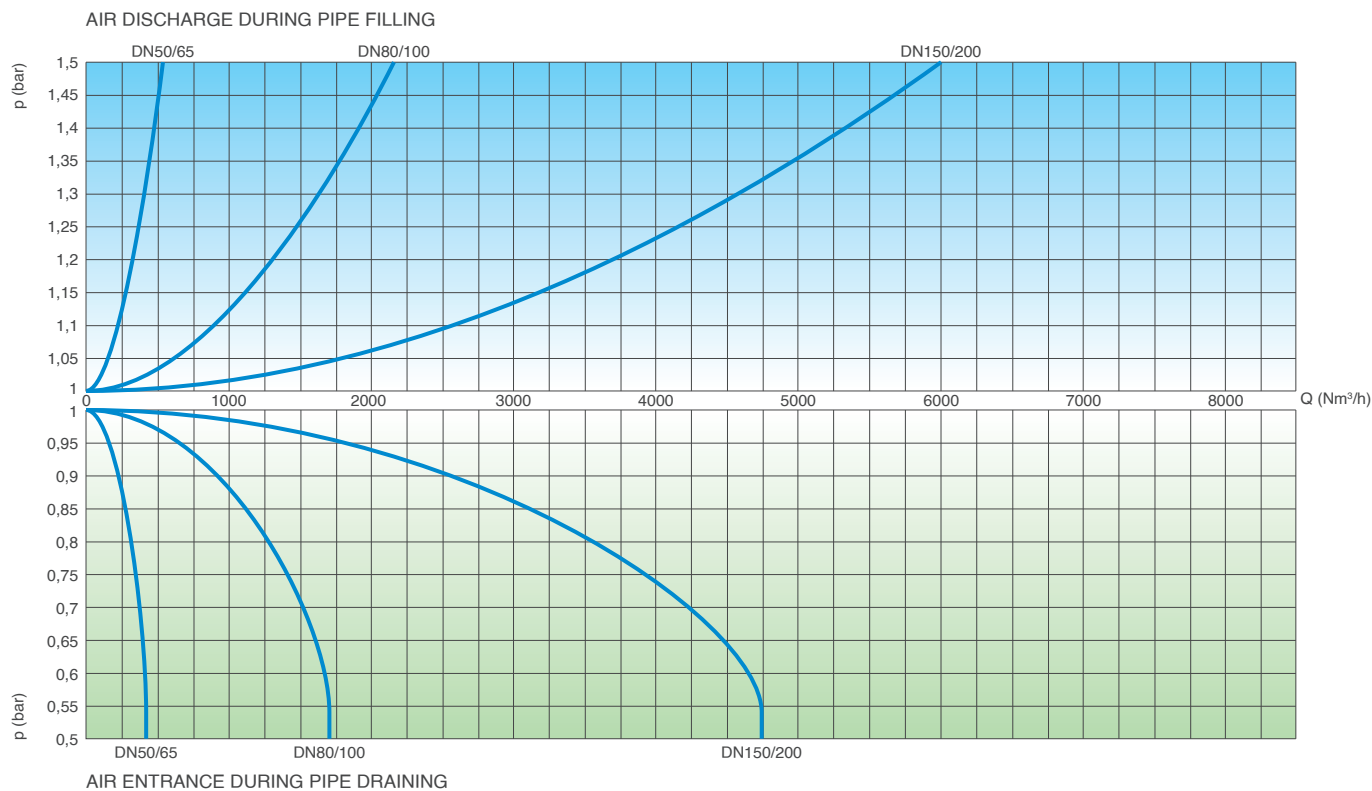

Working conditions

Water and waste water max. 60°C.
 Maximum pressure 16 bar.
 Minimum pressure 0,2 bar. Lower on request.
 Higher temperatures on request.

Standard

Certificated and tested in compliance with EN-1074/4.
 Flanges according to EN 1092/2.
 Epoxy painting applied through fluidized bed technology blue RAL 5005.
 Changes on the flanges and painting details available on request.

AIR RELEASE DURING WORKING CONDITIONS

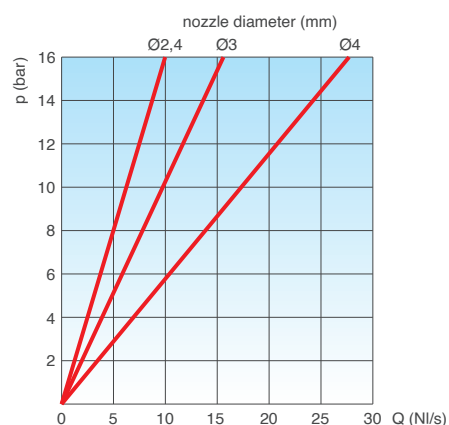

Nozzle choice

Nozzle diameter in mm according to the size of the air valve and the PN.

	PN 10	PN 16
DN 50/65	2,4	2,4
DN 80/100	3	3
DN 150/200	4	4

Weights and dimensions

DN mm	A mm	B mm	B' mm	C mm	D mm	Weight Kg
50/65	185	-	650	300	190	29
80/100	220	600	-	350	202	40
150	285	850	-	488	243	78
200	340	850	-	488	243	82

All values are approximate, consult PF service for more details.

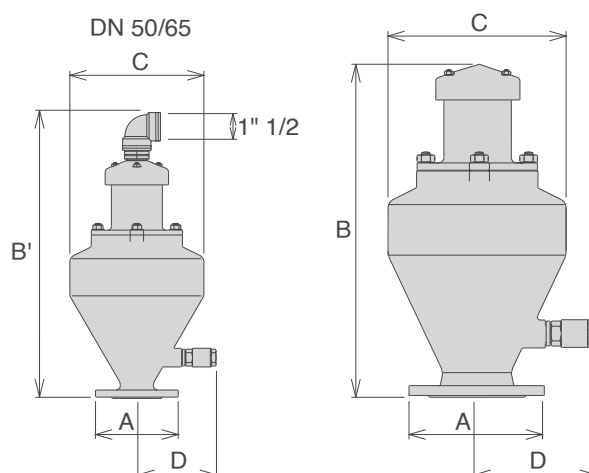

Technical details

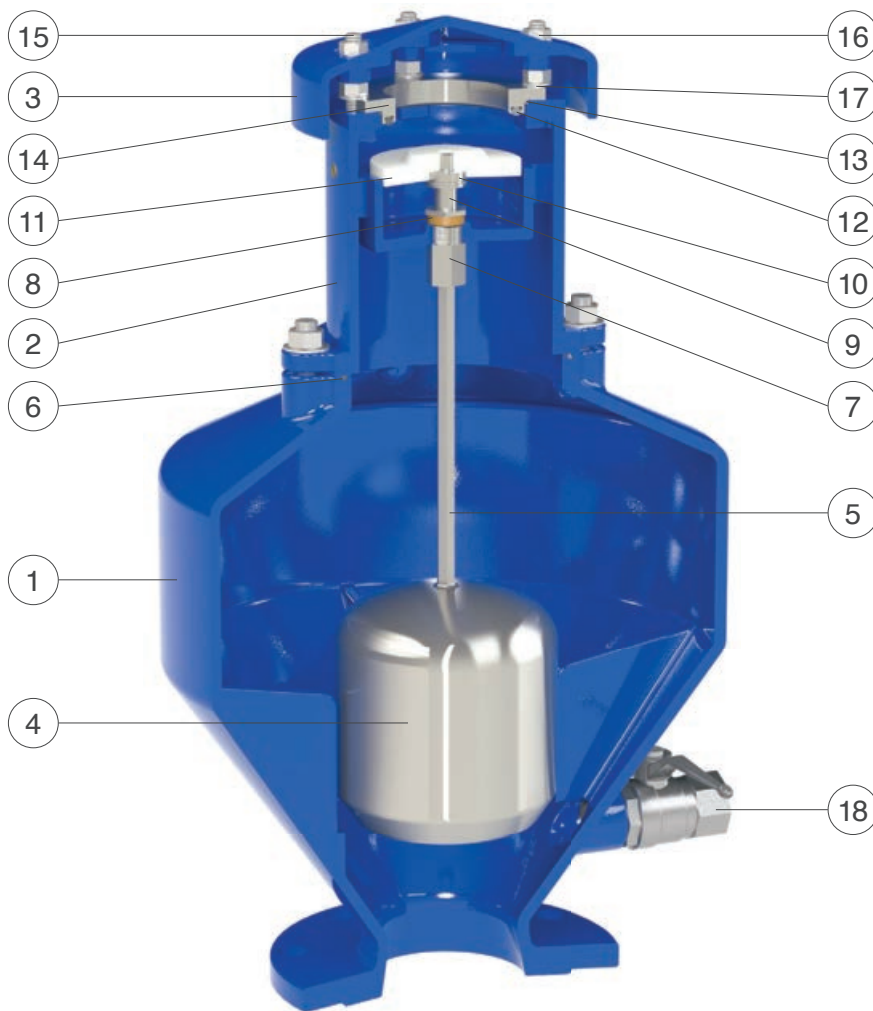

Threaded PP evacuation bend 1" 1/2 supplied as a standard for DN 50/65.

N.	Component	Standard material	Optional
1	Lower body	ductile cast iron GJS 450-10	
2	Upper body	ductile cast iron GJS 450-10	
3	Cap	ductile cast iron GJS 450-10	
4	Float	stainless steel AISI 316	
5	Float shaft	stainless steel AISI 316	
6	O-ring	NBR	EPDM/Viton/silicone
7	Driving sleeve	stainless steel AISI 303	stainless steel AISI 316
8	Plane gasket	NBR	
9	Gasket holder	stainless steel AISI 316	
10	Nozzle subset	stainless steel AISI 316	
11	Obturator flat	polypropylene	
12	Seat gasket	NBR	EPDM/Viton/silicone
13	O-ring	NBR	EPDM/Viton/silicone
14	Seat	stainless steel AISI 304 (AISI 303 for DN 50/65)	stainless steel AISI 316
15	Studs	stainless steel AISI 304	stainless steel AISI 316
16	Nuts	stainless steel AISI 304	stainless steel AISI 316
17	Washers	stainless steel AISI 304	stainless steel AISI 316
18	Ball valve 1"	stainless steel AISI 316	

The list of materials and components is subject to changes without notice.