

Fast acting anti-water hammer valve with flanged outlet - Mod. H-PVS 90F

The PF fast acting, surge prevention, pressure relief valve Mod. H-PVS 90F has been designed to avoid the devastating effects of water hammers in pipeline networks. The purpose is actually to prevent pressure from rising above a pre-set value, thanks to its capability of discharging the excessive volume of water through its flanged outlet.



Technical features and benefits

- Solid and compact design suitable for treated and raw water and to reduce blow-back.
- Negligible inertia of the internal mobile parts ensuring the absence of friction and long lasting performances.
- Perfect water tightness and excellent resistance to cavitation and harsh working conditions due to the floating obturator technology and to the use of special gaskets and high resistant stainless steel grades.
- Fast and accurate response without any hysteresis effect thanks to high frequency annealed springs.
- Wide selection of spring and ranges in pressure.
- Flanged outlet which allows to direct the water outflow through a discharge pipe.
- The valve is supplied with a pressure gauge and drainage ball valve, in order to facilitate the pressure measurement and setting procedure directly on the field.

Applications

- Downstream of pumping stations to cushion sudden overpressure as a result of pump start up and power failure (in case of one or more pumps in parallel).
- Downstream and upstream of main transmission lines, or pipe segments, not able to endure critical conditions such as sudden and unexpected rise in pressure, and to guarantee reliable system protection.
- Downstream of a pressure reducing valve as a safety device.
- Upstream of modulating and sectioning devices with rapid response time, likely to generate unwanted surges.
- In general, whenever unwanted upsurges may occur.

Operating principle

The valve must be pre-set at first, simply acting on the spring, to open whenever the pressure rises above a certain value considered critical for the system.



Valve normally closed

Without any incoming pressure the H-PVS 90F is a normally closed valve, as shown in the picture, where the obturator is kept pushed down to the seat by the force of the spring.

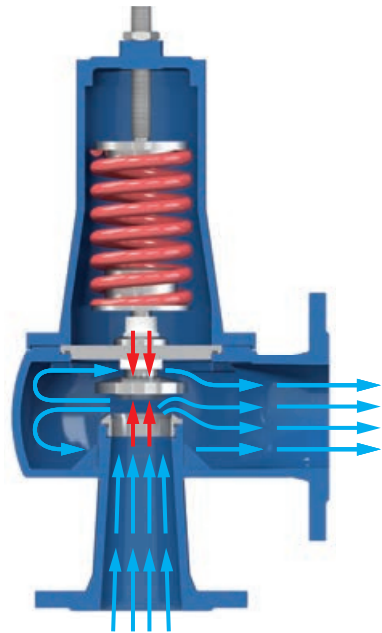

Valve fully open

Should the upstream pressure rise above the set point of the valve, obtained by the compression of the spring, the H-PVS 90F will open completely allowing the full passage through the seat.

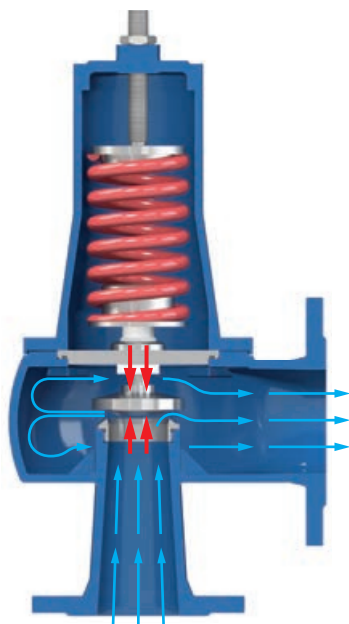

Valve modulating

Should the upstream pressure fluctuate around the valve's set point the obturator, thanks to the difference in force between the spring pushing downwards and the incoming pressure underneath pushing upwards, will move throttling the flow through the seat in order to maintain the minimum required pressure value.



Valve fully closed (static conditions)

Should the water supply and upstream pressure begin to drop, the H-PVS 90F will react immediately to maintain and stabilize the required value even in static conditions, thanks to the pressure balanced mobile block.

Technical data

DN (mm)	50/65	80	100	150
Kv (m ³ /h)	50	101	158	273
Stroke (mm)	17	21	23,5	35

Head loss coefficient

Kv coefficient representing the flow rate which is flowing through the valve fully open, and producing a head loss of 1 bar.

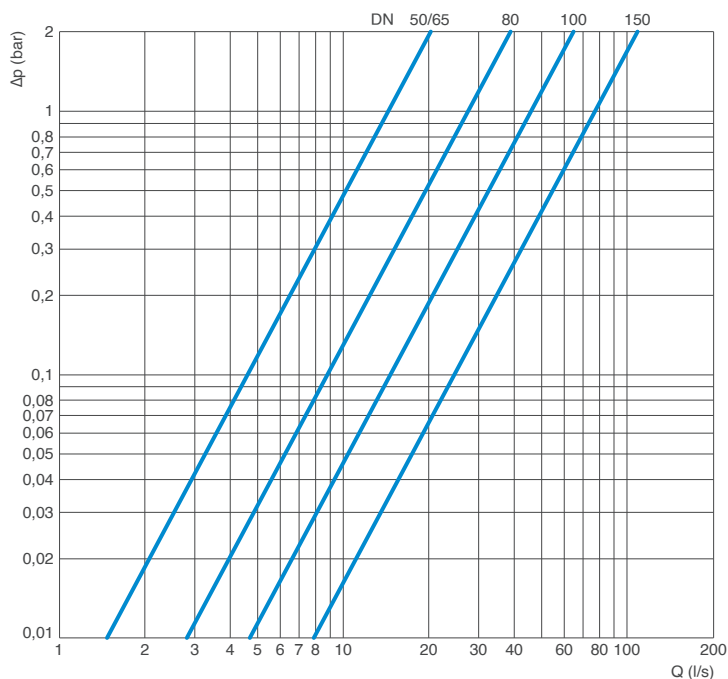

Head loss chart

The chart indicates the head loss of the valves fully open versus flow rate in l/s.

DN mm	PN bar	Setting bar	Overpressure bar
50/65	10	1-8	0,8
50/65	16	8-16	1,5
50/65	25	16-25	2,2
80	10	1-8	1
80	16	8-16	2
80	25	16-25	2,5
100	10	1-8	1
100	16	8-16	2
100	25	16-25	2,5
150	10	1-8	2
150	16	8-16	2,5
150	25	16-25	3,5

Overpressure

The table shows the overpressure of the valve with different pressure set-points. The H-PVS 90F are supplied with three springs to cover the following pressure ranges:

- 1-8 bar,
- 8-16 bar,
- 16-25 bar.

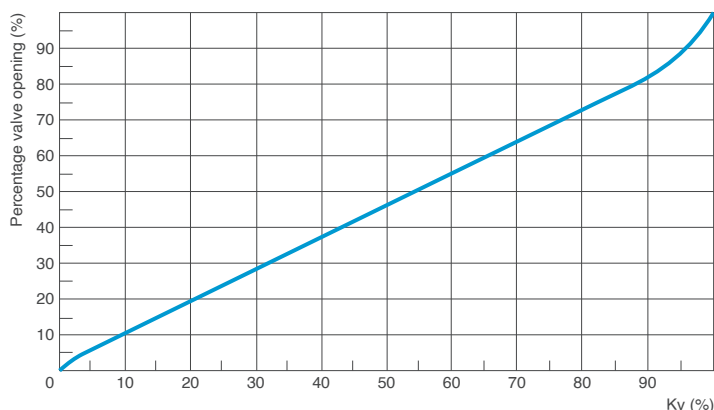

Kv to valve opening chart

The chart aside shows the opening percentage of the valves versus the Kv.

Technical data

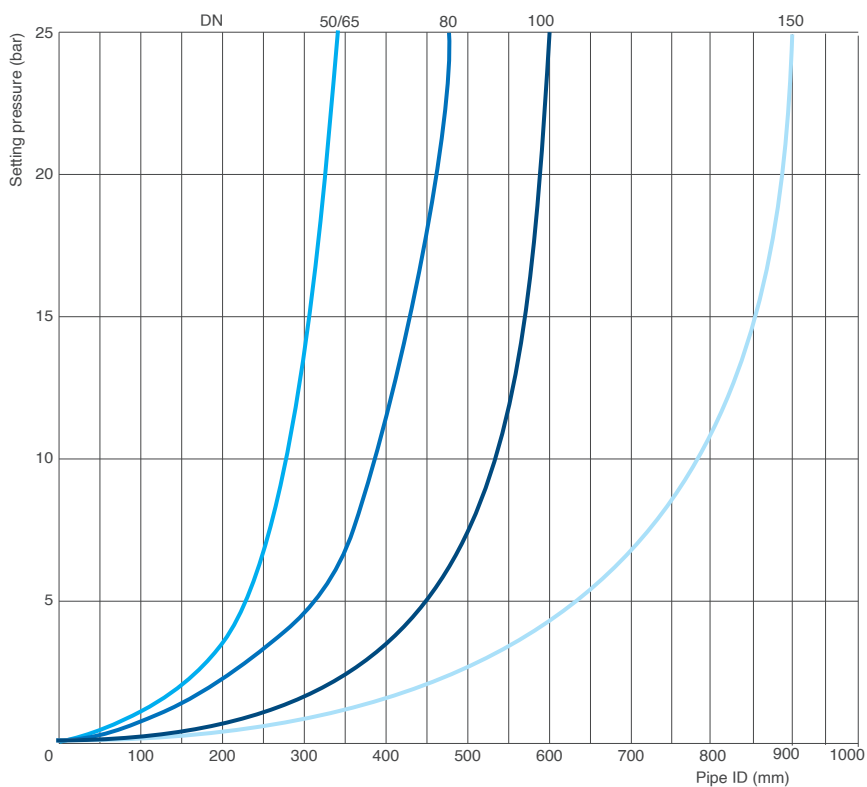

Preliminary sizing chart

The function of the fast acting relief valve PF Mod. H-PVS 90F is to protect piping systems, pumps, vessels and other equipment from excess in pressure and potential damages.

For the sizing overpressure values, blow-down effects and installation criteria must be taken into account, purely as an indication and for a preliminary assessment use the following chart showing the recommended valve's DN versus pressure setting and pipe ID. Ensure that the operating conditions fall on the left of the curve of the chosen valve.

DN (mm)	50/65	80	100	150
Flow rate max. (l/s)	12,5	26	41	72

Advised flow rates

The table shows the recommended maximum flow rates for the different sizes.

Working conditions

Treated and row water.
Maximum temperature of 70°C.
Maximum pressure 25 bar.
Spring setting ranges: 1-8 bar, 8-16 bar, 16-25 bar.

Standard

Certified and tested in compliance with EN 1074/5.
Flanges according to EN 1092/2.
Epoxy painting blue RAL 5005 applied through fluidized bed technology. Changes on flanges and painting on request.

Weights and dimensions

Inlet DN mm	A mm	B mm	C mm	D mm	E mm	F mm	G mm	Seat DN mm	Outlet DN mm	Weight Kg
50/65	185	188	418	100	200	130	150	43,5	80	20
80	200	244	542	130	235	184	177	60	100	36
100	235	244	567	130	270	196,5	177	75	125	41
150	300	409	758	165	360	235	335	100	200	111

Values are approximate, consult PF service for more details.

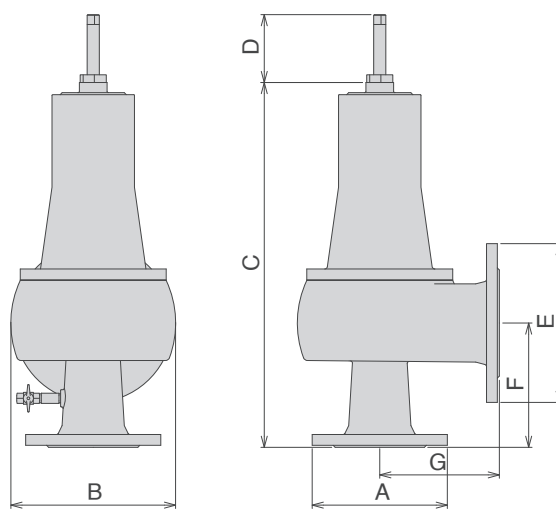

Examples of common applications

Pumping station. The following picture shows a characteristic application of the fast acting pressure relief valve H-PVS 90F, installed downstream of pumps check valves. Particular of the installation with an anti surge combination air valve PF WAVE or WAVE LITE 3S-AWH for the protection against negative pressure conditions.



Pressure reduction valve station. In this second layout H-PVS 90F is installed downstream of a pressure reduction valve station to prevent in any case rise in pressure on the main line. The installation also includes the pressure reducing valve PF H-VAL 310/410, a by-pass for maintenance and anti-surge combination air valves WAVE or WAVE LITE 3S-AWH upstream and downstream.

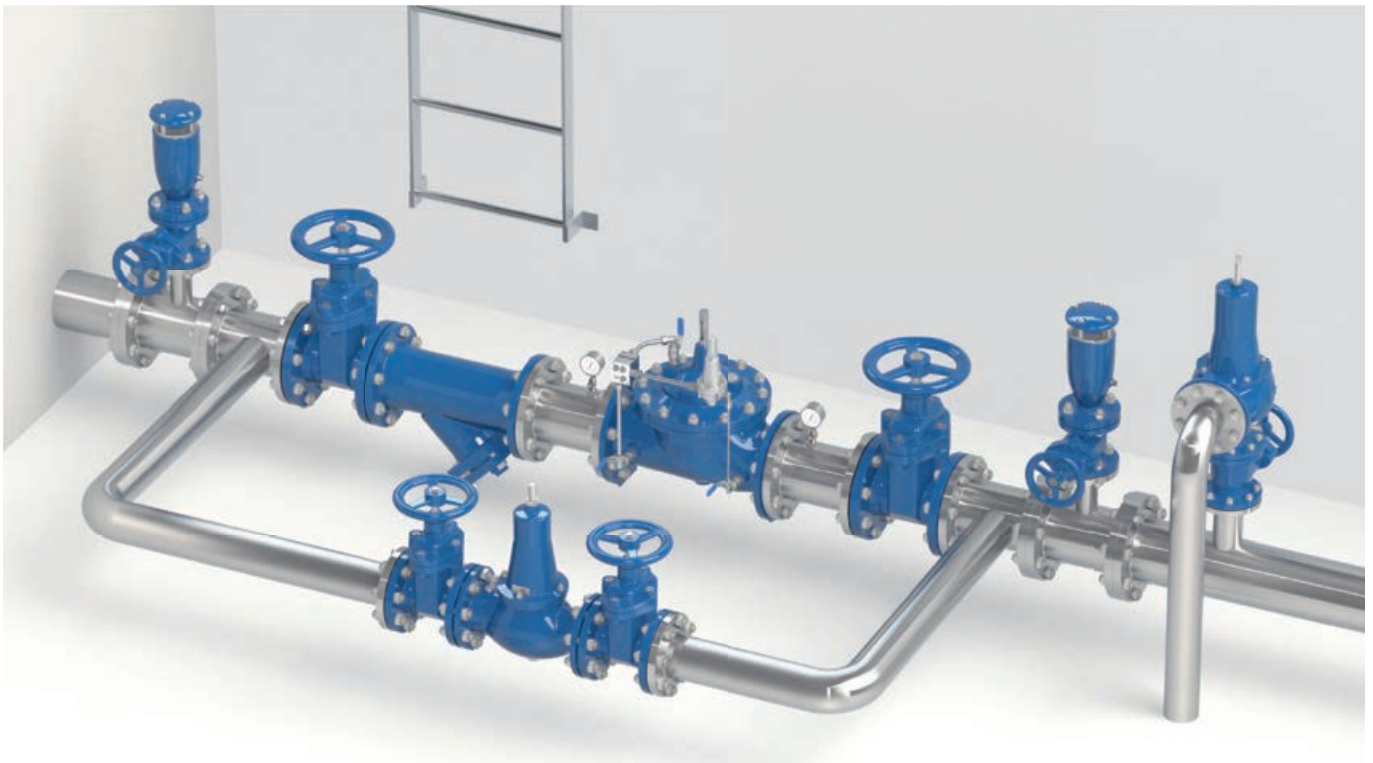

Technical details

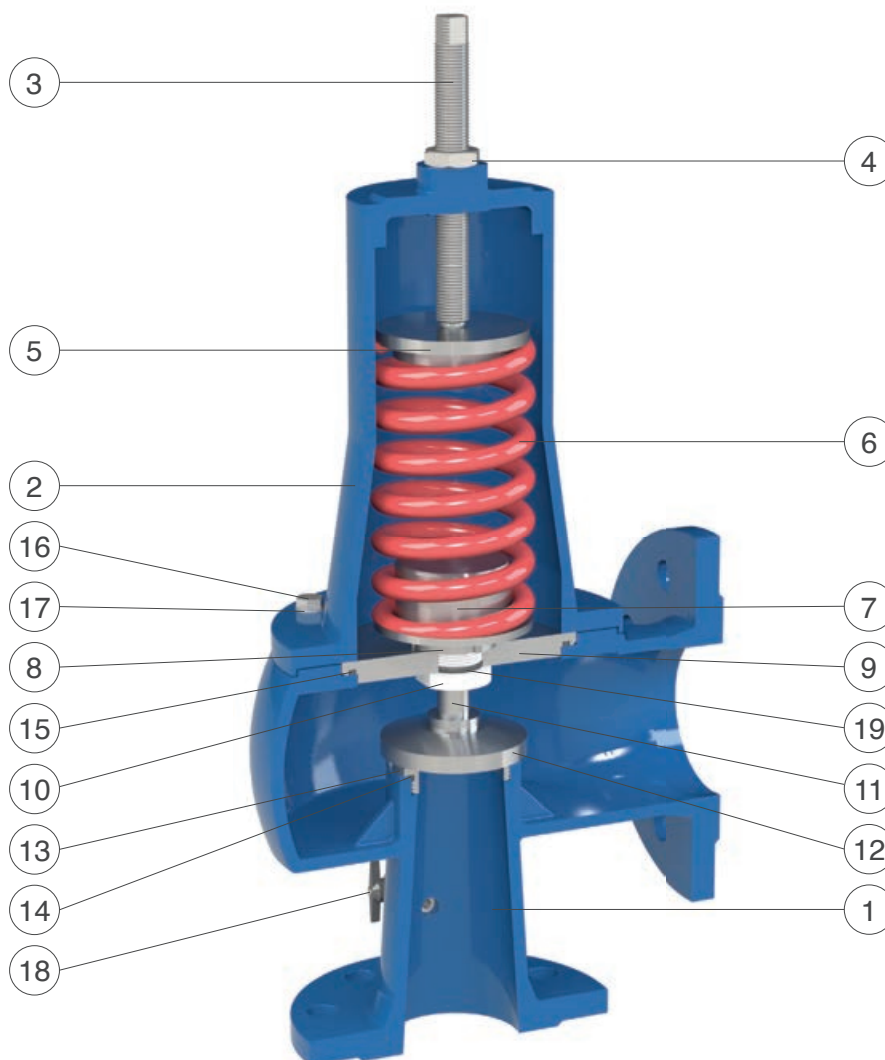

N.	Component	Standard material	Optional
1	Body	ductile cast iron GJS 450-10	
2	Cap	ductile cast iron GJS 450-10 and painted steel	
3	Driving screw	stainless steel AISI 304	stainless steel AISI 316
4	Nut	stainless steel AISI 304	stainless steel AISI 316
5	Spring support	stainless steel AISI 303 (304 for DN 150-200)	stainless steel AISI 316
6	Spring	spring painted steel 52SiCrNi5	
7	Spring housing	stainless steel AISI 303 (304 for DN 150-200)	stainless steel AISI 316
8	Ring	stainless steel AISI 304	stainless steel AISI 316
9	Separation plate	s.s. AISI 304 (painted steel for DN 150-200)	stainless steel AISI 316
10	Driving sleeve with O-ring	Delrin (s. s. AISI 304 for DN 150-200) and NBR	
11	Shaft	stainless steel AISI 304	stainless steel AISI 316
12	Obturator with plane gasket	st. st. AISI 303 (304 for DN 150-200) and polyurethane	stainless steel AISI 316
13	Sealing seat	stainless steel AISI 304 (303 for DN 50/65)	stainless steel AISI 316
14	O-ring	NBR	EPDM/Viton
15	O-ring	NBR	EPDM/Viton
16	Screws	stainless steel AISI 304	stainless steel AISI 316
17	Washers	stainless steel AISI 304	stainless steel AISI 316
18	Ball valve 1/4"	nickel-plated brass	stainless steel AISI 316
19	O-ring	NBR	EPDM/Viton

The list of materials and components is subject to changes without notice.