

# Downstream pressure reducer-stabilizer for high pressure - Mod. W-FLUX

The PF direct acting pressure reducing valve Mod. W-FLUX reduces and stabilizes the downstream pressure to a constant value, regardless of flow rate variations. It can be used for water, air and fluids in general up to a temperature of 70° C and a maximum pressure of 64 bar.



## Technical features and benefits

- Flanged version DN 50-150 PN 64 rated.
- Ductile cast iron cap and body in electro-welded steel, piston and mobile block in stainless steel.
- Upstream and downstream pressure balanced, to stabilize the downstream pressure to a pre-set (and adjustable) value regardless of upstream pressure variations without creating unwanted upsurges.
- Innovative self cleaning piston technology (patent pending) to improve performances reducing maintenance operations.
- Mobile block composed of three components in gun metal/stainless steel obtained by CNC to ensure the maximum accuracy and sliding precision, this is to avoid friction and unexpected leakage.
- Upstream and downstream pressure outlets for gauges.
- Large expansion chamber and materials providing an excellent resistance to cavitation and long lasting performances.
- Epoxy powder applied using FBT technology.

## Applications

- Water distribution systems for high pressure ratio.
- Mining.
- Industry and cooling systems.
- Dams and power plants.

## Operating principle

The operating principle of W-FLUX is based on a piston sliding into two rings in stainless steel/bronze of different diameters. These rings, tightly connected to the body, form a watertight chamber also known as the compensation chamber which is necessary for the accuracy and stability of the valve.

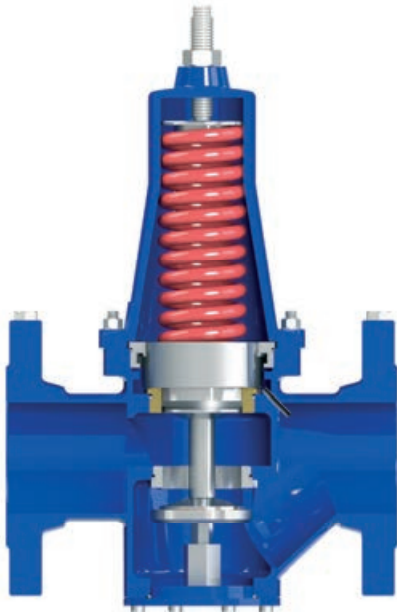

### Valve normally open

Without any pressure the W-FLUX is a normally open valve, where the piston is kept pushed down by the force of the spring located in the cover.

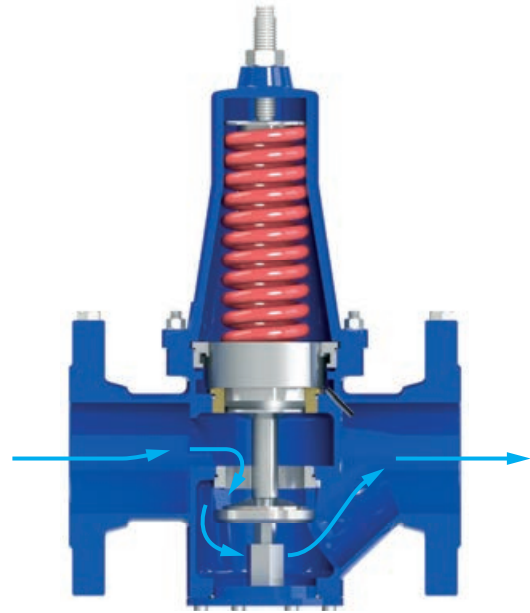

### Valve fully open

During working conditions, should the downstream pressure drop below the valve's set point obtained by the compression of the spring, the W-FLUX will open completely allowing the full passage.

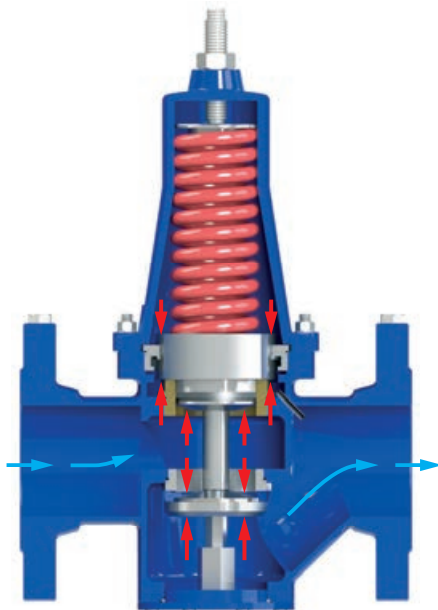

### Valve modulating

Should the downstream pressure rise above the valve's set point the resultant of the force obtained by the downstream pressure, acting on the mobile block and the compensation chamber against the spring pushing downwards, will move the obturator producing the required head loss to modulate and stabilize the downstream pressure.

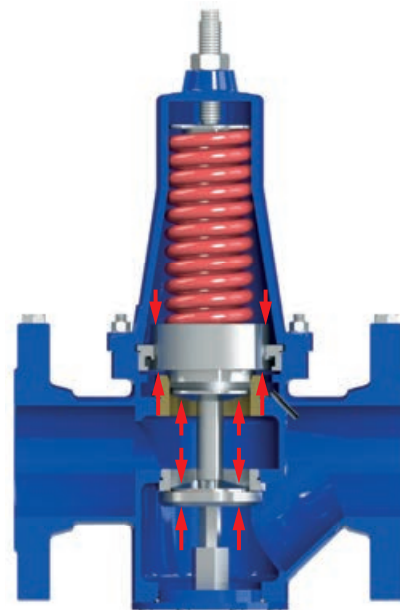

### Valve fully closed (static conditions)

Should the water supply be interrupted from downstream the system will go in static conditions, the W-FLUX will maintain and stabilize the required pressure even with no flow thanks to the pressure balanced technology and compensation chamber.

## Technical data

DN (mm)	50	80	100	150
Kv (m <sup>3</sup> /h)/bar	18	63	98	147

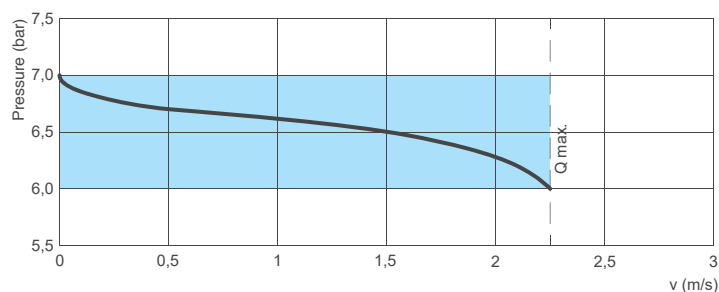
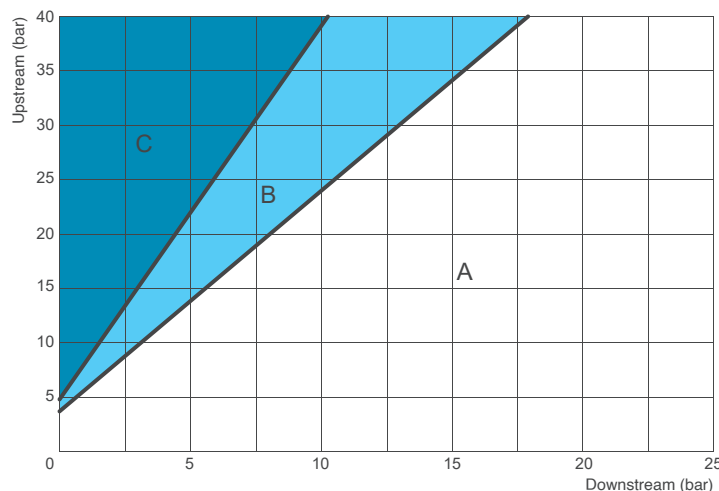

## Working conditions

Treated water with a maximum temperature of 70°C.  
 Upstream pressure (inlet): maximum 64 bar.  
 Downstream pressure (outlet): standard from 1,5 to 6 bar or from 5 to 12 bar. Higher values on request.

## Recommended flow rate

DN (mm)	50	80	100	150
Flow rate min. (l/s)	0,3	0,8	1,2	2,6
Flow rate max. (l/s)	3,9	10	15	40
Exceptional (l/s)	6,9	17	27	61

## Weights and dimensions

DN (mm)	50	80	100	150
A (mm)	230	310	350	480
B (mm)	90	108	126	172
C (mm)	240	340	400	500
Weight (Kg)	15	29	40	90

Values are approximate, consult PF service for more details.

## Head loss coefficient

Kv coefficient representing the flow rate which is flowing through the valve fully open producing a head loss of 1 bar.

## Cavitation chart

- A: Recommended working conditions;
- B: Incipient cavitation;
- C: Damage cavitation.

Ensure that the working point, obtained connecting upstream (y axis) and downstream (x axis) pressure conditions, falls on the A zone with the smallest valve to meet the required flow.

The chart is to be used for valves modulating with an opening percentage between 35-40% at standard water temperature and elevation below 300 m. For continuous pressure reduction the maximum allowed  $\Delta p$  shall not exceed 24 bar, for higher values contact PF assistance.

## Reduced pressure falloff

The plot is showing the reduced pressure falloff that occurs through the valve when the flow increases. Ensure that the operating conditions fall on the area depicted in blue for the recommended fluid flow velocity through the valve.

## Standard

Certified and tested in compliance with EN 1074/5.  
 Flanges according to EN 1092/2. Epoxy painting applied through fluidized bed technology blue RAL 5005.  
 Changes on flanges and painting on request.

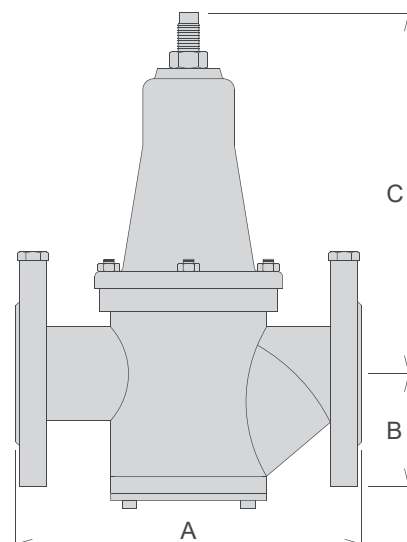

## Technical details

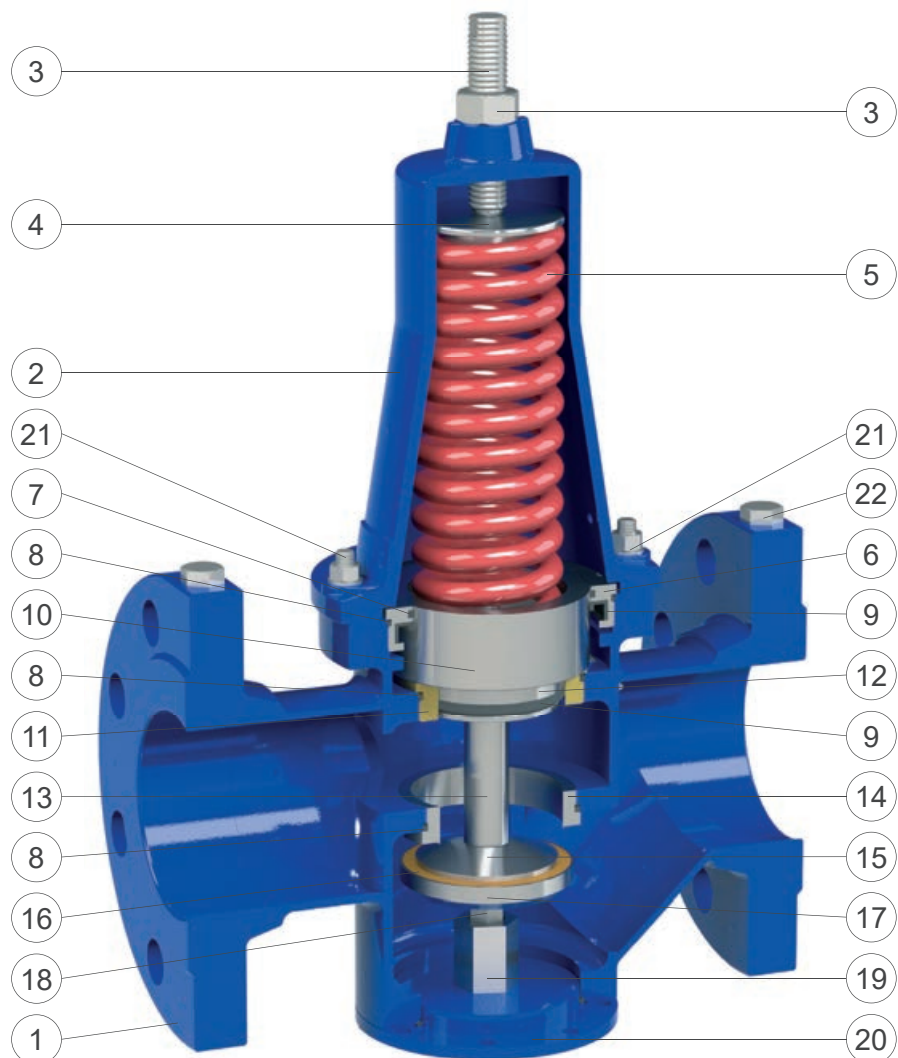

N.	Component	Standard material	Optional
1	Body	painted steel	
2	Cap	ductile cast iron GJS 450-10	
3	Driving screw and nut	stainless steel AISI 304	stainless steel AISI 316
4	Spring guide	stainless steel AISI 303	stainless steel AISI 316
5	Spring	spring painted steel 52SiCrNi5	
6	Main bush	stainless steel AISI 304	stainless steel AISI 316
7	Sliding ring	PTFE	
8	O-rings	NBR	EPDM/Viton
9	Gasket	NBR	EPDM/Viton
10	Upper piston	s.s. AISI 303 (bronze CuSn5Zn5Pb5 for DN 150)	stainless s. AISI 303/316
11	Lower reinforcements	bronze CuSn5Zn5Pb5	stainless s. AISI 304/316
12	Lower piston	stainless steel AISI 303	stainless steel AISI 316
13	Spacer	stainless steel AISI 303	stainless steel AISI 316
14	Obturator sealing seat	stainless steel AISI 304	stainless steel AISI 316
15	Gasket support	stainless steel AISI 303	stainless steel AISI 316
16	Plane gasket	polyurethane	
17	Obturator guide	stainless steel AISI 303	stainless steel AISI 316
18	Guiding shaft	stainless steel AISI 303	stainless steel AISI 316
19	Driving tap	stainless steel AISI 303	stainless steel AISI 316
20	Lower tap	painted steel	
21	Studs, nuts and washers	stainless steel AISI 304	stainless steel AISI 316
22	Taps for pressure gauges	stainless steel AISI 316	

The list of materials and components is subject to changes without notice.

## Spare parts breakdown

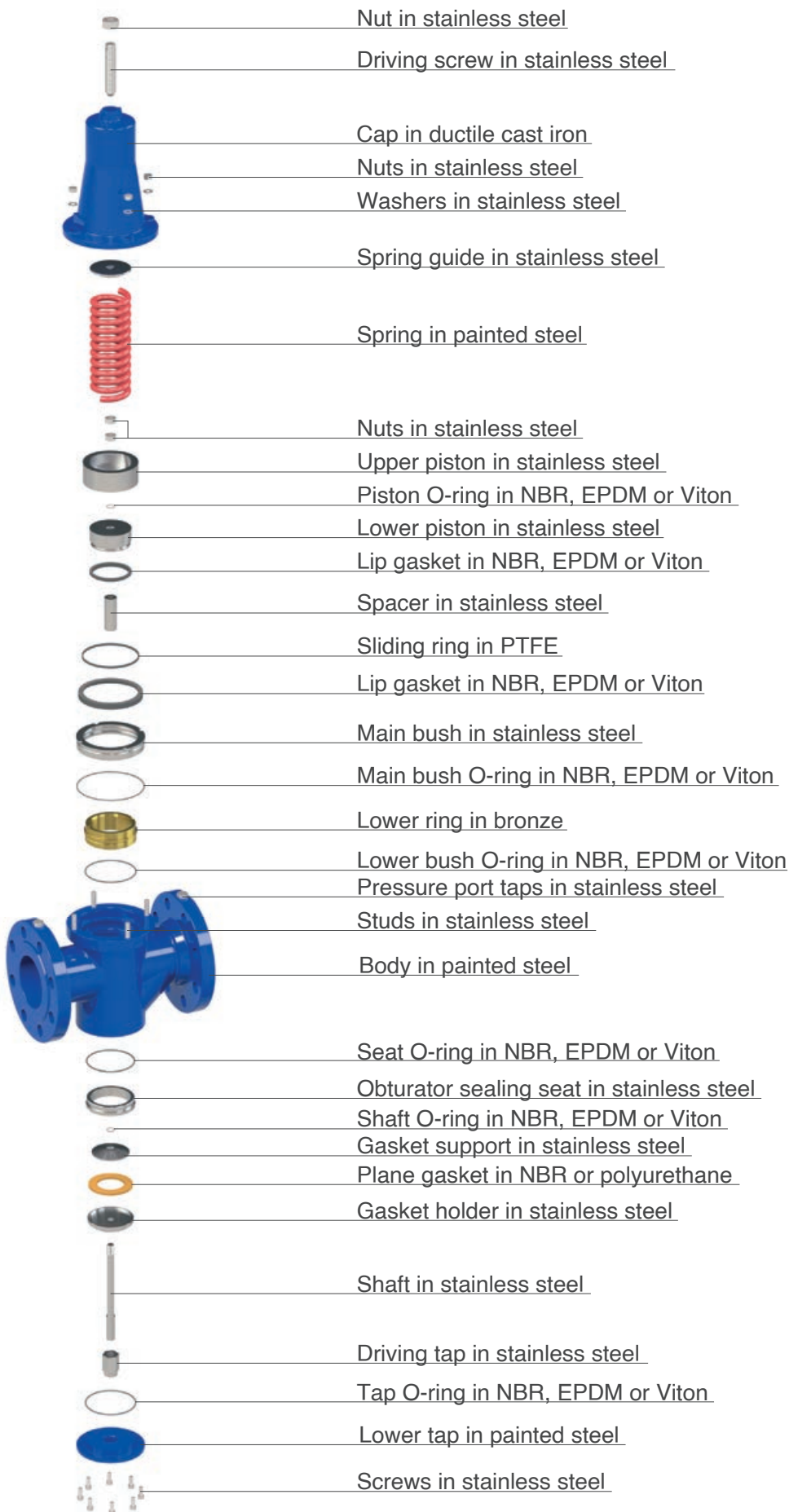

### Installation layout

The installation layout of the PF direct acting pressure reducer W-FLUX includes a strainer upstream to prevent the entrance of debris, stones and particles likely to damage the internal components, and sectioning devices needed for inspection and maintenance. PF anti-slam combination air valves WAVE 3S-AWH series are needed before and after the installation as well as PF direct acting pressure relief valve WR/AM located downstream, to discharge any possible increase in pressure.



### Installation layout

The picture shows PF pressure reducers installed in series, case of two steps pressure reduction applications, with the first as W-FLUX (in carbon welded steel) followed by the W-VAL HP line in ductile cast iron. The idea is to avoid excessive pressure dissipation on the W-VAL HP with the potential for cavitation and wear. Direct acting pressure sustaining/relief valves are located between the two PRV and downstream of the second to prevent dangerous rise in pressure, as well as to avoid damages on the ductile cast iron unit.

