

Combination air valve Mod. WAVE LITE 3S

The PF combination, triple function, automatic air valve Mod. WAVE LITE 3S will ensure the proper operation of the pipeline network allowing the release of air pockets during working conditions, the evacuation and entrance of large volumes of air during filling and draining operations.



Technical features and benefits

- Single chamber body in ductile cast iron, PN 40 bar rated, provided with internal ribs for accurate guiding of the floats.
- Aerodynamic deflector in stainless steel to avoid premature closures of the mobile block.
- Drainage valve, produced by PF, for chamber control and pressure relief during maintenance.
- Mobile block composed of a cylindrical float and upper disk in solid polypropylene, joined together by the PF air release system in AISI 316. The solid cylindrical floats, obtained by CNC machining, avoid deformations and ensure a great sliding precision inside the body processed ribs and a perfectly vertical thrust.
- Nozzle and gasket holder, part of PF air release system, entirely made in AISI 316 and designed with gasket compression control to prevent aging process and consequent leakage during working conditions.
- Maintenance can be easily performed from the top, without removing the air valve from the pipe.
- Cover in ductile and screen in stainless steel as a standard execution to prevent the entrance of insects, with three optional outlets (for submerged applications, air inlet only, air outlet only).

Applications

- Main transmission lines.
- Water distribution networks.
- Irrigation systems.
- In general this model is used on changes in slope and at the high points of the pipeline.

Operating principle



Discharge of large volumes of air

During the pipe filling it is necessary to discharge air as water flows in. The WAVE LITE 3S, thanks to the aerodynamic body and the deflector, will make sure to avoid premature closures of the mobile block during this phase.



Air release during working conditions

During operation the air produced by the pipeline is accumulated in the upper part of the air valve. Little by little it is compressed and the pressure arrives to water pressure, therefore its volume increases pushing the water level downwards allowing the air release through the nozzle.



Entrance of large volumes of air

During pipeline draining, or pipe bursts, it is necessary to bring in as much air as the quantity of outflowing water to avoid negative pressure and serious damages to the pipeline, and to the entire system.

Optional



- **Vacuum breaker version Mod. WAVE LITE 2S**, to allow the entrance and discharge of large volumes of air only. This model is normally recommended in changes in slope ascending, long ascending segments, dry fire systems, and wherever the air release won't be required.



- **Version for submerged applications, SUB series**, available both for WAVE LITE 3S and 2S Models, with threaded elbow for air conveyance. The design sprang from the necessity of having an air valve performing also in case of flood, without the risk of contaminated water entering the pipeline. Another benefit of SUB is the possibility of conveying spurts coming from the rapid closure of the air valve.



- **Version for air discharge only EO series**, available both for WAVE LITE 3S and 2S models. The most important application of EO is to allow the air valve installation in those locations of the system where HGL may drop below the pipe profile, and to any other node where for project requirements air entrance must be avoided, such as in pump suction lines or siphons pipelines.

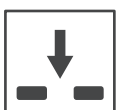

- **Version for air entrance only IO series**, available for WAVE LITE 2F model only. The most important application of IO is to allow the air valve installation in those locations of the system where, for project requirements, air discharge and release must be avoided.

Technical data

Air flow performance charts

AIR DISCHARGE DURING PIPE FILLING

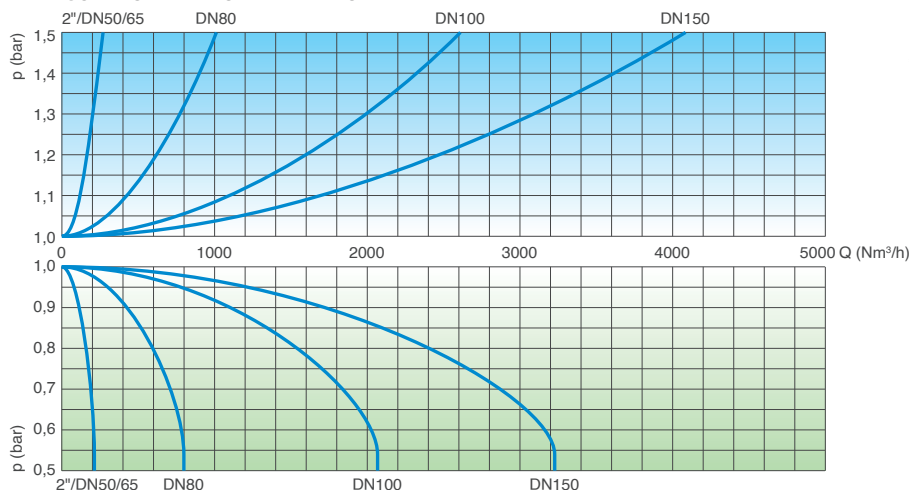

AIR ENTRANCE DURING PIPE DRAINING

AIR DISCHARGE DURING PIPE FILLING

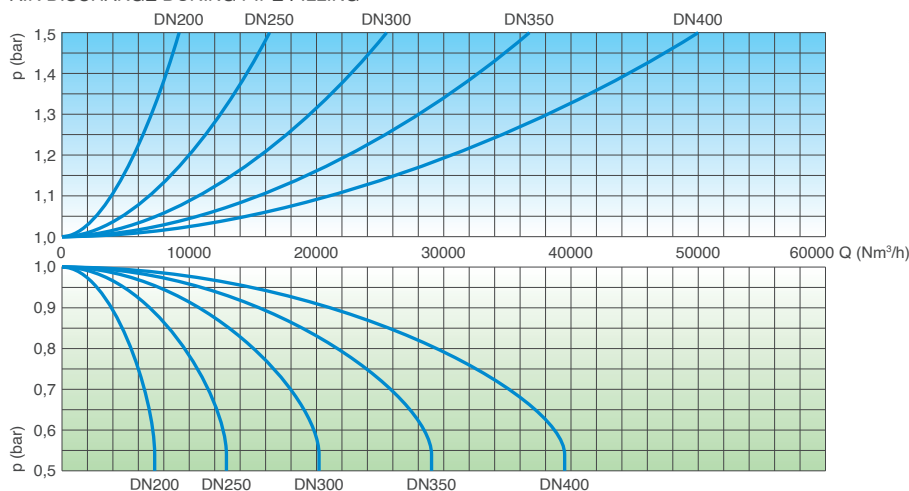

AIR ENTRANCE DURING PIPE DRAINING

Working conditions

Treated water max. 60°C.
Max. pressure 40 bar.
Min. pressure 0,2 bar. Lower on request.

Standard

Designed in compliance with EN-1074/4 and AWWA C-512. Flanges according to EN 1092/2 or ANSI 150. Epoxy painting applied through fluidized bed technology blue RAL 5005. Changes on the flanges and painting on request.

Weights and dimensions

CONNECTION inch/mm	A mm	B mm	C mm		D mm	Weight Kg
Threaded 2"	117	240	-	-	CH 70	4,8
Flanged 50	117	250	165	-	-	6,8
Flanged 65	117	250	185	-	-	7,6
Flanged 80	141	305	210	205	-	10,8
Flanged 100	172	303	235	220	-	13,8
Flanged 150	206	337	305	285	-	23,0
Flanged 200	285	555	375	340	-	55,0
Flanged 250	365	635	450	405	-	101,0
Flanged 300	420	785	515	455	-	127,0
Flanged 350	515	940	580	520	-	250,5
Flanged 400	600	1075	620	580	-	304,0

Nozzle choice

Nozzle diameter in mm according to the air valve size and the PN.

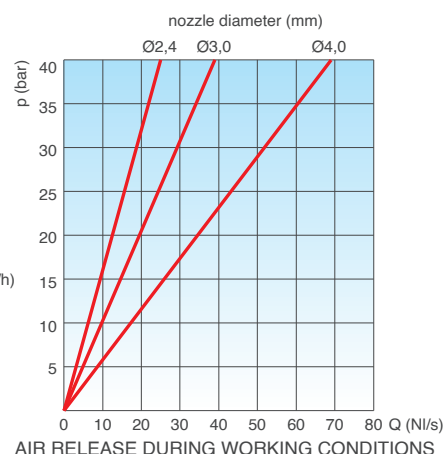
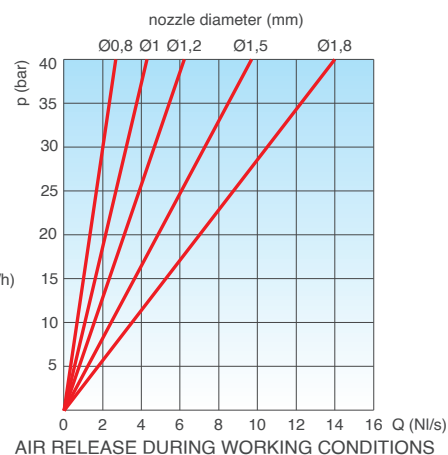

The air flow charts were created in Kg/s from laboratory tests and numerical analysis, without the screen, then converted in Nm³/h using a safety factor.

	PN 10	PN 16	PN 25	PN 40
2"-DN 65	1,2	1,2	1	0,8
DN 80	1,8	1,5	1,2	0,8
DN 100	1,8	1,5	1,2	1
DN 150	2,4	1,8	1,8	1,2
DN 200	4	3	2,4	1,8
DN 250	4	4	3	2,4
DN 300	4	4	4	4
DN 350	4	4	4	4
DN 400	4	4	4	4

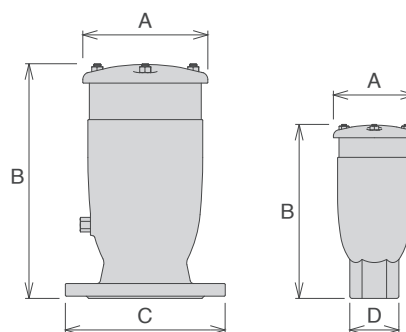

Values are approximate, consult PF service for more details.

Technical details

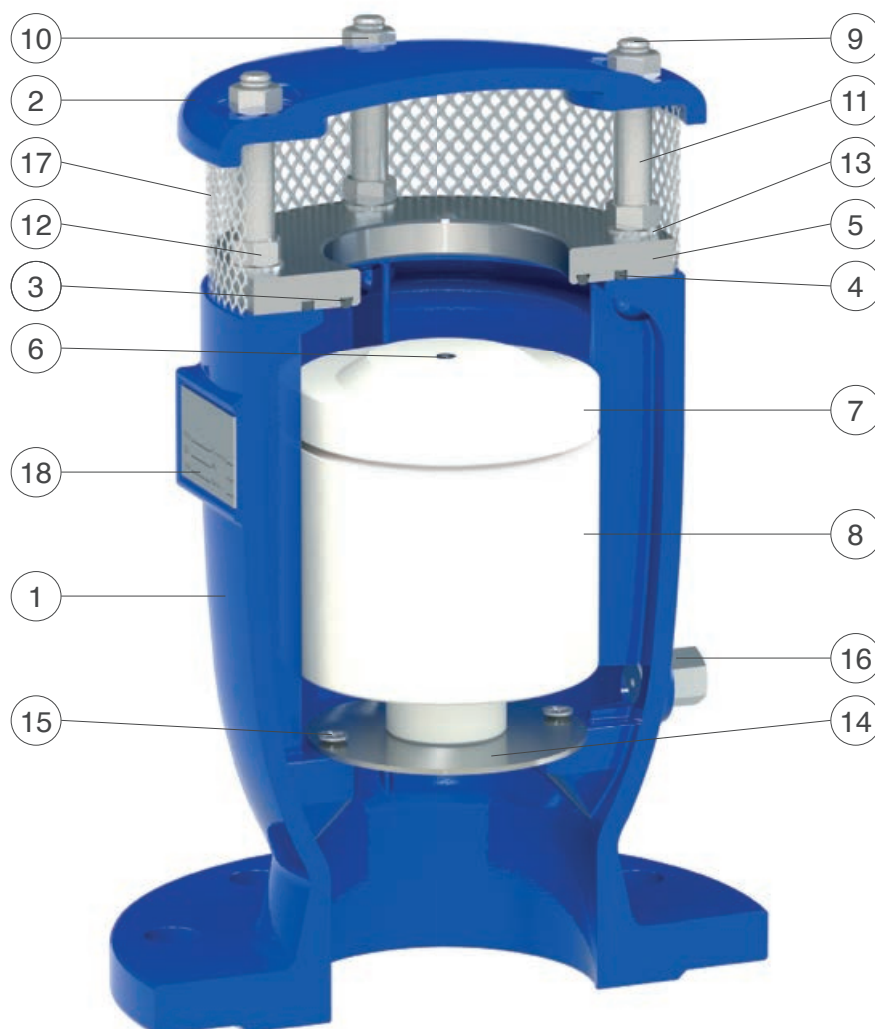

N.	Component	Standard material	Optional
1	Body	ductile cast iron GJS 450-10	
2	Cap	ductile cast iron GJS 450-10	
3	O-ring	NBR	EPDM/Viton/silicone
4	O-ring	NBR	EPDM/Viton/silicone
5	Seat	stainless steel AISI 304	stainless steel AISI 316
6	Nozzle Subset	stainless steel AISI 316	
7	Upper flat	polypropylene	
8	Float	polypropylene	
9	Studs	stainless steel AISI 304	stainless steel AISI 316
10	Nuts	stainless steel AISI 304	stainless steel AISI 316
11	Spacers	stainless steel AISI 304	stainless steel AISI 316
12	Nuts	stainless steel AISI 304	stainless steel AISI 316
13	Washers	stainless steel AISI 304	stainless steel AISI 316
14	Deflector (not in 1")	stainless steel AISI 304	stainless steel AISI 316
15	Screws	stainless steel AISI 304	stainless steel AISI 316
16	Drain valve	stainless steel AISI 303	stainless steel AISI 316
17	Screen	stainless steel AISI 304	
18	Tag	stainless steel AISI 304	

The list of materials and components is subject to changes without notice.