



## **Pillar Hydrant**

# Pillar Hydrant series PF-SAFE 247

Technical Features	4
In harmony with the environment	5
360° Orientability	5
Breaking system	5
Obturator	6



## ■ Pillar Hydrant Mod. PF-SAFE 247

Technical features and benefits	7
Technical details	8



## ■ Pillar Hydrant Mod. PF-SAFE 247-S

Technical features and benefits	9
Technical details	10

## Pillar fire hydrant PF-SAFE 247 series

The pillar fire hydrant series PF-SAFE 247, designed in conformity with the applicable European standards, is composed of two models entirely manufactured in ductile cast iron and stainless steel with technical features to reach the highest standards in product safety and quality. Their design, production process and performances contribute to create a reliable product proudly made in Italy.



### **Mod. PF-SAFE 247 DN 80-100 PN 16**

This non-freezing pillar fire hydrant model, equipped with apparent outlets, is supplied with up to 6 different heights of the underground column including the duck foot bend. Thanks to a breaking system, acting on the connection between the upper body and the lower barrel, the risk of severe damages and pressure loss for the water distribution system is avoided in case of sudden impact by a vehicle. The winged shaped obturator, anti-water hammer and anti-vibrations, allows the water discharge through the anti-freezing hole only when the hydrant is fully closed reducing leakage and water loss unavoidable by using different technologies such as flat shutters.



### **Mod. PF-SAFE 247-S DN 80-100 PN 16**

This non-freezing pillar fire hydrant model, equipped with protecting hood manufactured in ductile cast iron, is supplied with up to 6 different heights of the underground column including the duck foot bend. Thanks to a breaking system, acting on the connection between the upper body and the lower barrel, the risk of severe damages and pressure losses for the water distribution system is avoided in case of sudden impact by a vehicle. The winged shaped obturator, anti-water hammer and anti-vibrations, allows the water discharge through the anti-freezing hole only when the hydrant is fully closed avoiding leakage, otherwise unavoidable by using different technologies such as flat shutters. The hood will prevent tampering reducing at the same time environmental impact, by means of its modern and pleasant design.

## Technical features

### 1. Overall painting

To guarantee the best resistance against corrosion and in compliance with potable water requirements all PF hydrants are subject to internal and external painting, more precisely black or blue RAL 5005 epoxy powders for the underground barrel and red polyester RAL 3000 for the upper body (above ground).

### 2. Internal components in stainless steel

All internals are manufactured in stainless steel and protected from contact with the ductile iron by means of components in bronze and brass.

### 3. Anti-friction technology

All components involved in the movement and rotation are designed to reduce friction and interferences as much as possible, in addition to innovative technical solutions, in order to reduce torque and excessive wearing.

### 4. Obturator anti-water hammer and anti-vibration (see page 7)

### 5. Anti-freezing drainage hole

In case of low temperatures with risk of frost it is necessary to allow the complete drainage of the hydrant once the closed position has been reached. PF manufactures all hydrants with anti-freezing drainage hole obtained on the sealing ring, onto which the rubber coating of the obturator is acting, embedded inside the base either supplied with a duck foot bend or vertical connection.

### 6. Breaking system (see page 6)

### 7. Safety system of the obturator

The water tightness on PF hydrants is obtained by the compression of the rubber coating of the obturator, made in ductile cast iron, against the sealing ring housed inside the lower base either supplied as a duck foot bend or vertical connection. This solution avoids excessive wearing and frequent maintenance, as well as reducing the torque necessary for the complete closure. Should the latter be excessive, an innovative construction detail will prevent under any circumstances any possible damage to the obturator mobile block.

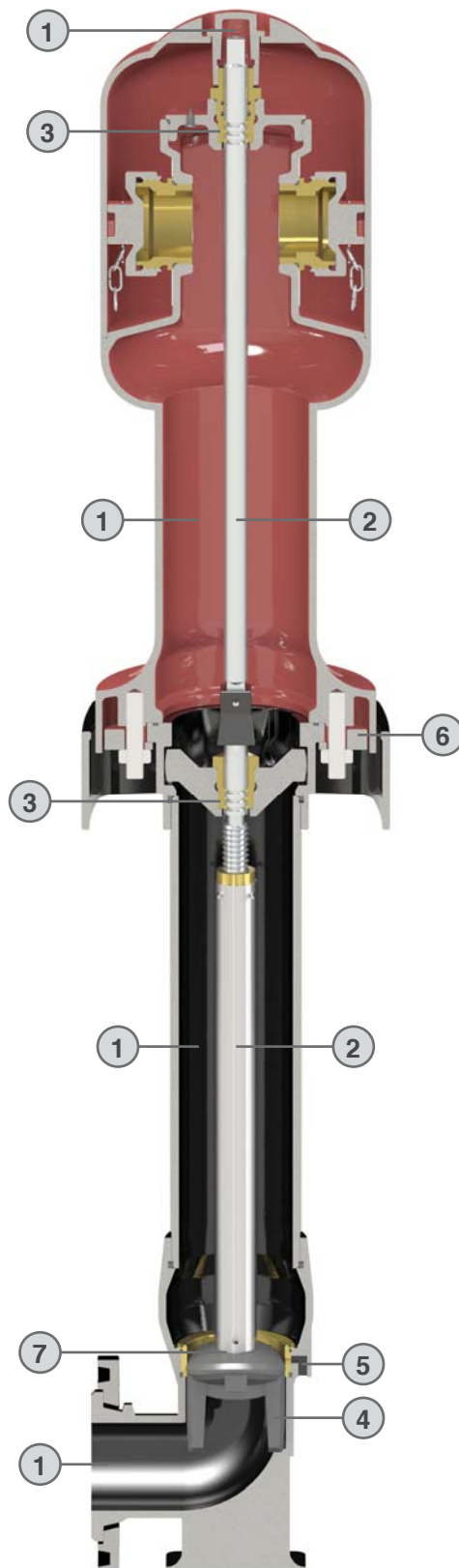



## In harmony with the environment

Created by a famous architect, specialized in environmental impact assessment, PF hydrants stand out for their appearance, shape and modern design integrating perfectly with the surrounding be it a park, historical downtown or simply a street. Supplied either with protecting hood or apparent outlets, they all include an anti-freezing device and safety breaking system.

## 360° Orientability

All the PF pillar fire hydrants are 360° orientable, thanks to the special coupling system with cylindrical seat between the upper body and the underground column. The full orientability reduces the time required for the installation and any extra costs.

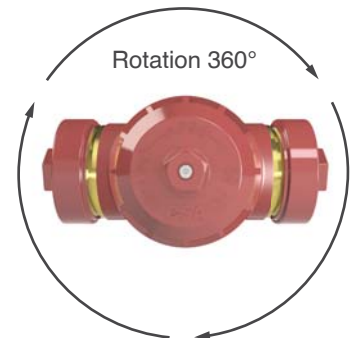

## Breaking system

Pillar fire hydrants are most of the time located on sidewalks, parking areas, and places subject to vehicle traffic and accessible to the fire brigade trucks and law enforcement. The risk of collision with the hydrant is therefore always possible and sometimes unavoidable. The PF breaking system is equipped on the 247 models with apparent outlets, and 247-S models with protecting hood. Designed to act both as a connection between the upper body and the underground column and as a safety breakable device in case of impact, by means of a sacrificial flange breaking in predetermined points, the system will break under the traction force as consequence of the momentum created between the buried barrel and the upper body during the impact. To this end we highlight the importance of leaving at least 5 cm distance between the ground level and the breaking system itself. Failing in doing so will prevent the upper part from falling over.

Thanks to the effect of the breaking system, in the event of an accident, the car or the vehicle hitting against hit won't suffer severe damages, the hydrant will remain fully closed without leakage and pressure variations for the water distribution system. Simply replacing the connection flange and, if required, the o-ring between it, will enable a full recovery of the hydrant without extra costs.

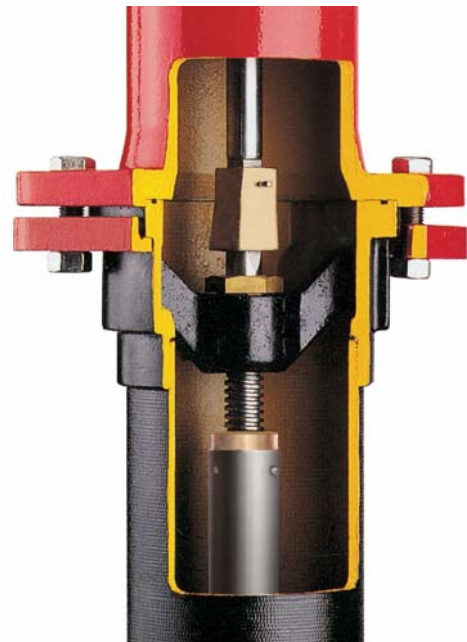

*Breaking system spare parts 247 and 247-S:  
2 breakable semi-flanges, 4 bolts, 1 gasket*

## Obturator

The PF obturator, manufactured in ductile cast iron fully coated with NBR vulcanized or EPDM, is a winged shaped cone performing a perfect water tightness by means of the compression of its cylindrical part against the sealing ring housed inside the base of the hydrant, either duck foot bend or vertical connection. The coating is applied on three different layers where the one in the middle closes the anti-freezing drainage hole, while the two remaining will prevent any kind of vibration.

This design allows:

- a water tightness in presence of high pressure values, even higher than 25 bar;
- the absence of any kind of interference with foreign materials that can enter the hydrant;
- a gradual variation of low and pressure during opening and closing, preventing unwanted water hammer event sand/or sudden drop in pressure.

**Water leakage and loss reduction.** The winged shaped obturator will avoid, under any circumstances, to put in communication the drainage anti-freezing hole with the upstream pressure, which is happening all the time during the usage of the hydrant and the manoeuvres with flat disks and technologies not equivalent to PF. When that occurs huge amounts of water are wasted through concealed water loss.



## Operating principle

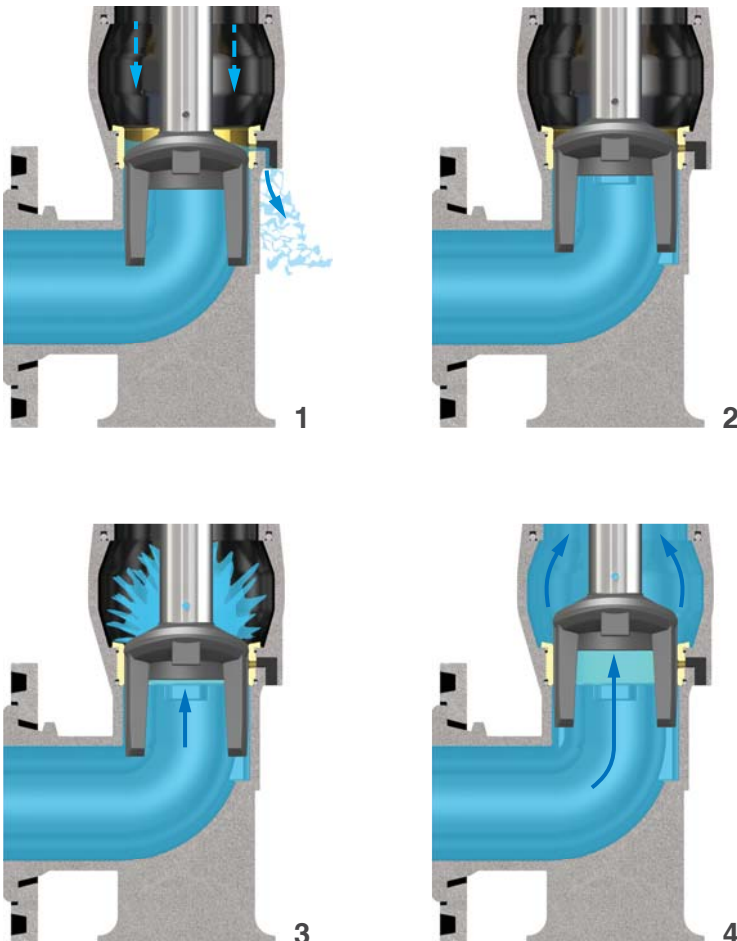

**1. Obturator to the fully closed position.** Perfect water tightness with the drainage anti-freezing hole fully open.

Water trapped inside the pillar fire hydrant pours out of the drainage hole avoiding possible damages caused by frost.

**2. Obturator to the initial opening phase.** Perfect water tightness. The drainage hole is closed before putting the upstream pressure in communication with the hydrant.

**3. Obturator to the intermediate opening phase.** Flow rate increasing gradually. The drainage hole is always closed as the obturator is progressing upwards.

**4. Obturator to the fully open position.** Flow rate through the hydrant and to the outlets has reached the maximum value, the drainage anti-freezing hole is always closed. Absence of vibrations thanks to the winged shaped obturator.

# Pillar hydrant

## Mod. PF-SAFE 247

The PF pillar fire hydrant Mod. PF-SAFE 247 is composed of an upper body and an underground part, entirely made in ductile cast iron and stainless steel, joined together by a breakable system activated in case of impact of a vehicle. Designed in keeping with the applicable European standards this model features apparent outlets and an exclusive anti-leakage and surge prevention vibration proof obturator, housed inside the duck foot bend supplied as a standard with the hydrant.



### Technical features and benefits

- Upper body in ductile cast iron GJS 450-10 PN 16 bar rated, red RAL 3000 polyester powder coated for the maximum resistance to UVA exposure.
- Underground part composed of duck foot bend, barrel, driving box, adjustable flanges entirely made in ductile cast iron black or blue epoxy paint coated.
- Exclusive PF breaking system simple and reliable.
- Pentagonal caps machined to avoid and limit as much as possible unauthorized water consumption.
- Anti-freezing device.
- Internals in stainless steel to increase resistance to corrosion, safety and performances over time.
- Exclusive winged shaped obturator, with core in ductile cast iron NBR or EPDM coated to avoid water hammer effect during opening and closing, minimize vibrations during usage and prevent water loss through the anti-freezing hole.
- Sealing seat obtained by a ring threaded directly inside the PF duck foot bend, supplied as a standard with the hydrant and designed to reduce head loss and avoid damages also in case of stones, debris coming through the hydrant.
- The operating female screw pinned directly to the stand pipe for the highest resistance and safety.

## Technical details

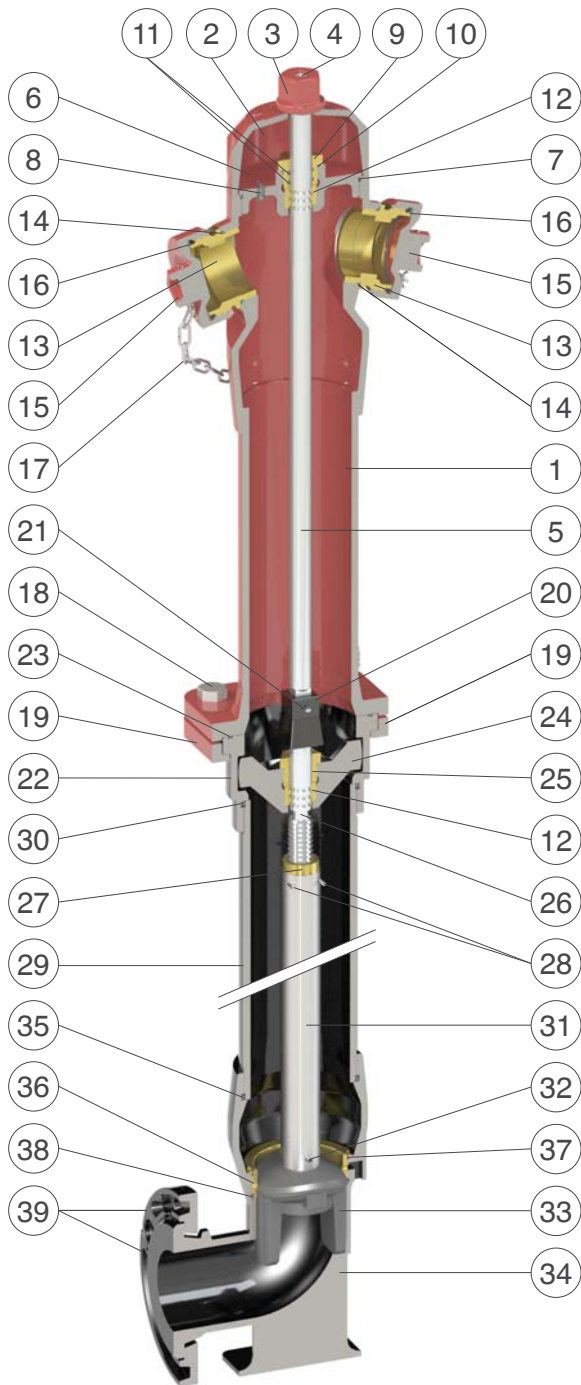

N.	Component	Material
1	Body	GJS 450-10
2	Cap	GJS 450-10
3	Operating nut	GJS 450-10
4	Screw	stainless steel
5	Stem	stainless steel
6	Guiding bonnet	GJS 450-10
7	O-ring gasket	NBR
8	Venting valve	NBR
9	Sealing screw	brass
10	O-ring gasket	NBR
11	O-ring gaskets	NBR
12	Half sleeves	brass
13	Fittings	brass
14	O-ring gaskets	NBR
15	Caps	GJS 450-10
16	Plane gaskets	EPDM
17	Chains	stainless steel
18	Screws and nuts	stainless steel
19	Breakable semi-flanges	GS 20
20	Connection sleeve	GJS 450-10
21	Cotter pin	stainless steel
22	Driving box	GJS 450-10
23	O-ring gasket	NBR
24	Equipped stem holder	GJS 450-10
25	Setting screw	brass
26	Operating stem	stainless steel
27	Female screw	bronze
28	Pins	stainless steel
29	Barrel	steel
30	O-ring gasket	NBR
31	Stand pipe	galvanized steel
32	Cotter pin	stainless steel
33	Obturator	GJS 450-10 NBR/EPDM coated
34	Duck foot bend	GJS 450-10
35	O-ring gasket	NBR
36	Sealing ring	bronze
37	O-ring gasket	NBR
38	O-ring gasket	NBR
39	Adjustable flanges	GJS 450-10

The list of materials and components is subject to changes without notice.

Model	A mm	B mm	C mm	D mm	H mm	Ø <sub>cap</sub> *• } { à^i à à^Op	Ø <sub>fl</sub> *^•	Y cē Kg
247 80A		736			1468			52
247 80B	682	886	50	130	1618	2Ø70	DN 80	56
247 80C		1036			1768			60
247 80D		1186			1918			63
247 100A		767			1499	2Ø70		70
247 100B	682	917	50	130	1649	+	DN 100	76
247 100C		1067			1799	1Ø100		81
247 100D		1217			1949			86

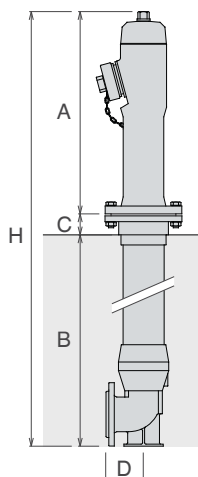

### Working conditions

Treated water maximum 70°C.

### Pressure testing

Test of mechanical resistance with obturator fully open at 25 bar and with obturator fully closed at 20 bar.

### Standard

Designed in compliance with EN 1074/6 and EN 14339.

Flanges according to EN 1092/2.

Polyester painting red RAL 3000 and epoxy black. Variations on the flanges and painting available on request.



## Pillar fire hydrant Mod. PF-SAFE 247-S

The PF pillar fire hydrant Mod. PF-SAFE 247-S is composed of an upper body and an underground part, entirely made in ductile cast iron and stainless steel, joined together by a breakable system activated in case of impact of a vehicle. Designed in keeping with the applicable European standards this model includes a protecting hood to avoid unauthorized water consumptions and an exclusive anti-leakage and surge prevention vibration proof obturator, housed inside the duck foot bend supplied as a standard with the hydrant.



### Technical features and benefits

- Upper body in ductile cast iron GJS 450-10 PN 16 bar rated, painted with red RAL 3000 polyester powder coated for the maximum resistance to UVA exposure.
- Protecting hood in ductile cast iron designed to minimize the environmental impact.
- Underground part composed of duck foot bend, barrel, driving box, adjustable flanges entirely made in ductile cast iron black or blue epoxy powder coated.
- Exclusive PF breaking system simple and reliable.
- Anti-freezing device.
- Nuts and bolts in stainless steel.
- Internals in stainless steel to maximize resistance to corrosion, safety and performances over time.
- Exclusive winged shaped obturator, with core in ductile cast iron NBR or EPDM coated to avoid water hammer effect during opening and closing, minimize vibrations during usage and prevent leakage.
- Sealing seat obtained by a ring threaded directly inside the PF duck foot bend, supplied as a standard with the hydrant and designed to reduce head loss and avoid damages also in case of stones, debris coming through the hydrant.
- The operating female screw pinned directly to the stand pipe for the highest resistance and safety.

## Technical details

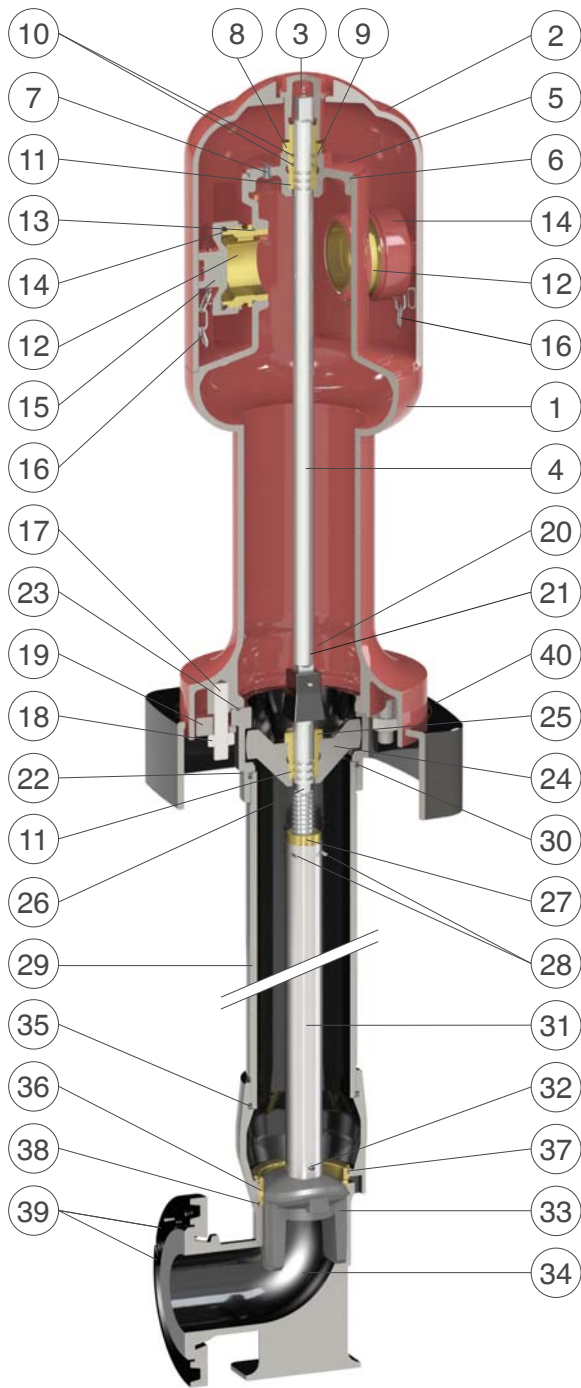

N.	Component	Material
1	Body	GJS 450-10
2	Hood	GJS 450-10
3	Hood sealing nut	GJS 450-10
4	Stem	stainless steel
5	Guiding bonnet	GJS 450-10
6	O-ring gasket	NBR
7	Venting valve	NBR
8	Sealing screw	brass
9	O-ring gasket	NBR
10	O-ring gaskets	NBR
11	Half sleeves	brass
12	Fittings	brass
13	O-ring gaskets	NBR
14	Caps	GJS 450-10
15	Plane gaskets	EPDM
16	Chains	stainless steel
17	Studs	stainless steel
18	Nuts	stainless steel
19	Breakable semi flanges	GS 20
20	Connection sleeve	GJS 450-10
21	Cotter pin	stainless steel
22	Driving box	GJS 450-10
23	O-ring gasket	NBR
24	Equipped stem holder	GJS 450-10
25	Setting screw	brass
26	Operating stem	stainless steel
27	Female screw	bronze
28	Pins	stainless steel
29	Barrel	steel/ductile cast iron
30	O-ring gasket	NBR
31	Stand pipe	stainless steel
32	Cotter pin	stainless steel
33	Obturator	GJS 450-10 NBR/EPDM coated
34	Duck foot bend	GJS 450-10
35	O-ring gasket	NBR
36	Sealing ring	bronze
37	O-ring gasket	NBR
38	O-ring gasket	NBR
39	Adjustable flanges	GJS 450-10
40	Adjusting baseboard	GJS 450-10

The list of materials and components is subject to changes without notice.

Model	A mm	B mm	C mm	D mm	H mm	Ø <sub>max</sub> * Ø <sub>min</sub> * Ø <sub>max</sub> * Ø <sub>min</sub> *	Y cē Kg
247-S 80A		513			1281		67
247-S 80B	678	663	50	130	1431	2Ø70	69
247-S 80C		813			1581		73
247-S 80D		963			1731		76
247-S 100A		673			1377	2Ø70	89
247-S 100B	680	823	50	130	1527	+ DN 100	95
247-S 100C		973			1677	1Ø100	100
247-S 100D		1123			1827		105

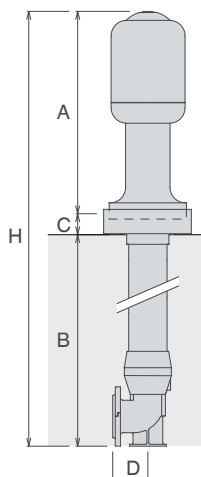

### Working conditions

Treated water maximum 70°C.

### Pressure testing

Test of mechanical resistance with obturator fully open at 25 bar and with obturator fully closed at 20 bar.

### Standard

Designed in compliance with EN 1074/6 and EN 14339.  
Flanges according to EN 1092/2.  
Polyester painting red RAL 3000 and epoxy black. Variations on the flanges and painting available on request.