



**Direct acting
valves**

Pressure control valves



- **Downstream pressure reducer-stabilizer
Mod. W-VAL HP**

The model reduces and stabilizes the downstream pressure to a constant value, regardless of flow rate and upstream pressure variations.

3



- **Downstream pressure reducer-stabilizer
Mod. W-VAL LP**

Reducer diaphragm operated for a high accuracy or regulation.
Maximum pressure 16 bar.

9



- **Downstream pressure reducer-stabilizer
in stainless steel Mod. W-VAL TH**

Model in stainless steel with a maximum working pressure of 64 bar and threaded connections.

13



- **Downstream pressure reducer-stabilizer
for high pressure Mod. W-FLUX**

Reducing-stabilizing valve with body in electro-welded steel for pressures up to 64 bar and flanged connections.

17



- **Pressure relief/sustaining valve
Mod. WR/AM**

This model maintains and sustains a pre-set upstream pressure value, discharging any excess downstream.

23



- **Pressure relief/sustaining valve
in stainless steel Mod. WR/AM TH**

Model in stainless steel with threaded connections.

29



- **Fast acting anti-water hammer valve
Mod. H-PVS**

The valve avoids the rising of the pressure above a pre-set value discharging the excessive volume of water directly into the atmosphere.

33



- **Fast acting relief valve with flanged outlet
Mod. H-PVS 90F**

Angle pattern Fast acting relief valve with outlet flanged connection

39



- **Fast acting relief valve in stainless steel
Mod. H-PVS TH**

Angle pattern Fast acting relief valve with threaded connection entirely made in stainless steel AISI 316

45

Downstream pressure reducer-stabilizer Mod. W-VAL HP

The PF direct acting pressure reducing valve Mod. W-VAL HP reduces and stabilizes the downstream pressure to a constant value, regardless of flow rate and upstream pressure variations. It can be used for water, air and fluids in general with a maximum working pressure of 40 bar.



Technical features and benefits

- Flanged version DN 50-150.
- Upstream and downstream pressure balanced, to stabilize the downstream pressure to a pre-set (and adjustable) value regardless of upstream pressure variations without creating unwanted upsurges.
- Ductile cast iron for body and cap, piston in stainless steel, seat in stainless steel, guiding bush in stainless steel as well as bolts and nuts.
- Innovative self cleaning piston technology to improve performances reducing maintenance operations.
- Mobile block composed of three components in gun metal/stainless steel obtained by CNC to ensure the maximum accuracy and sliding precision, this is to avoid friction and unexpected leakage.
- Upstream/downstream pressure outlets for gauges.
- Large expansion chamber to reduce noise and to provide an excellent resistance to cavitation.
- Epoxy powder applied using FBT technology.

Applications

- Water distribution systems.
- Buildings and civil installations.
- Irrigations.
- Cooling systems.
- Fire protection systems and in general whenever the pressure reduction has to be ensured.

Operating principle

The operating principle of W-VAL HP is based on a piston sliding into two rings in stainless steel/bronze of different diameters. These rings, tightly connected to the body, form a watertight chamber also known as the compensation chamber which is necessary for the accuracy and stability of the valve.

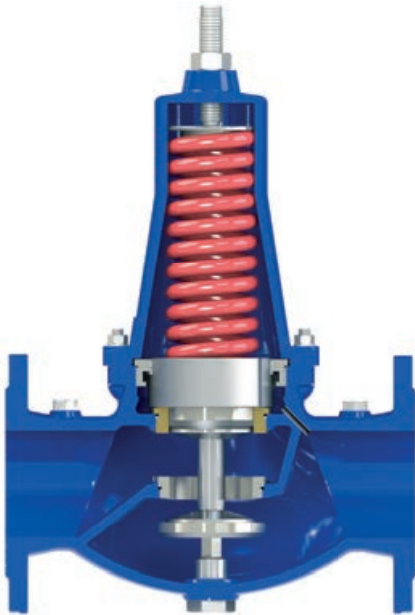

Valve normally open

Without any pressure the W-VAL HP is a normally open valve, where the piston is kept pushed down by the force of the spring located in the cover.

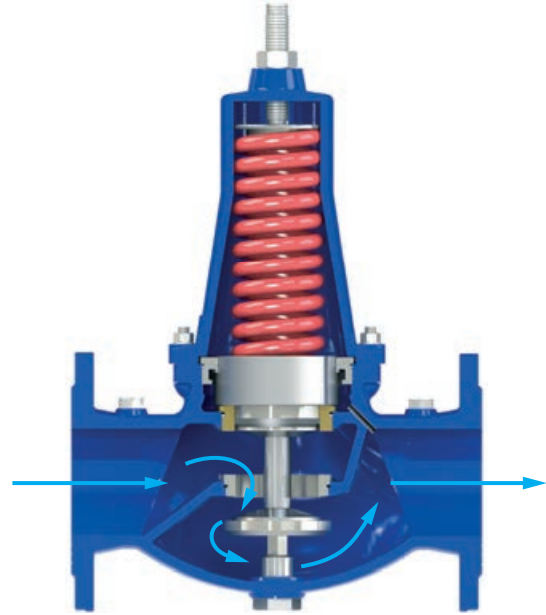

Valve fully open

During working conditions, should the downstream pressure drop below the valve's set point obtained by the compression of the spring, the W-VAL HP will open completely allowing the full passage.

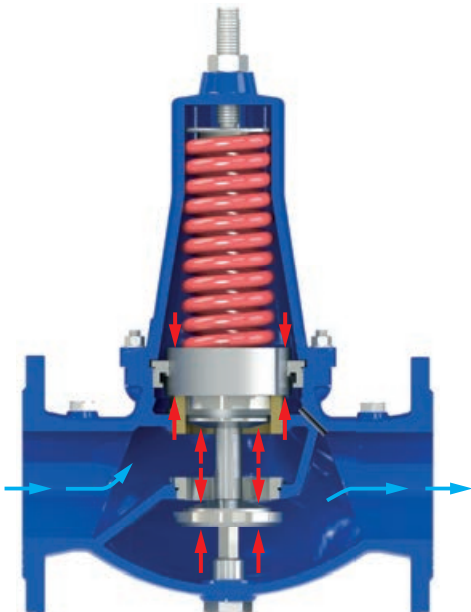

Valve modulating

Should the downstream pressure rise above the valve's set point the resultant of the force obtained by the downstream pressure, acting on the mobile block and the compensation chamber against the spring pushing downwards, will move the obturator producing the required head loss to modulate and stabilize the downstream pressure.

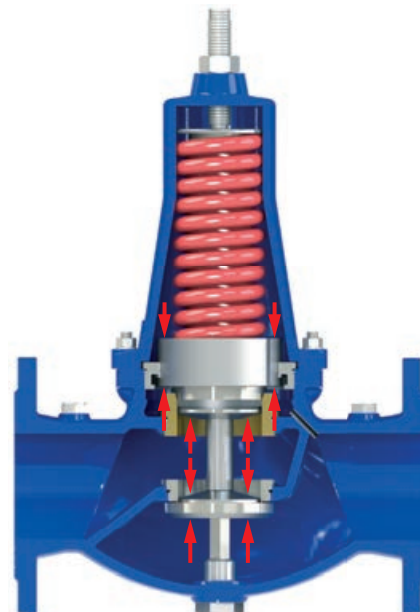

Valve fully closed (static conditions)

Should the water supply be interrupted from downstream the system will work in static conditions, the W-VAL HP will maintain and stabilize the required pressure even with no flow thanks to the pressure balanced technology and compensation chamber.

Technical data

DN mm	50	65	80	100	125	150
Kv (m ³ /h)/bar	20	47	72	116	147	172

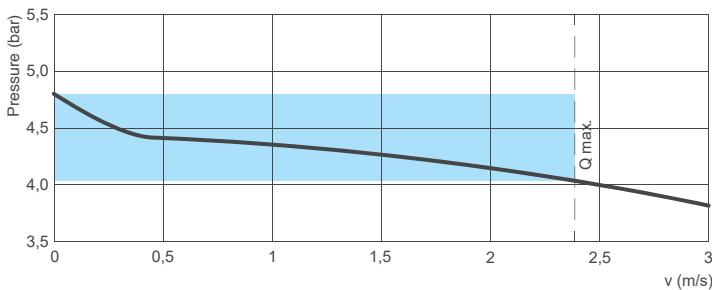
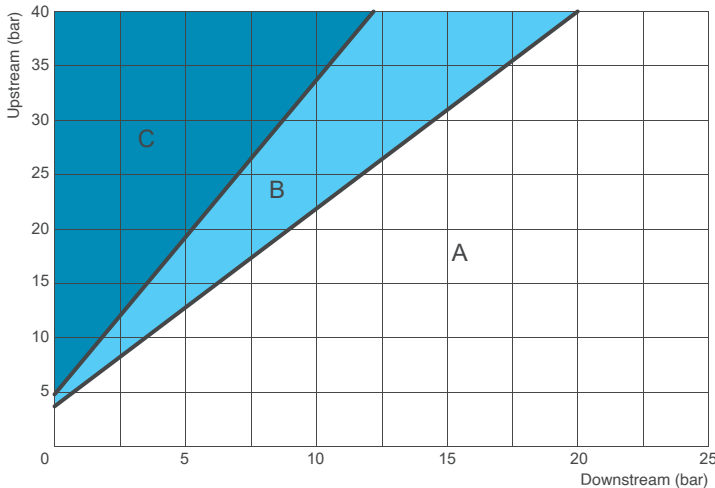

Working conditions

Treated water with a maximum temperature of 70°C.
 Upstream pressure (inlet): maximum 40 bar. Downstream pressure (outlet): adjustable from 1,5 to 6 bar or from 5 to 12 bar. Higher downstream pressure values on request.

Recommended flow rate

DN (mm)	50	65	80	100	125	150
Flow rate min. (l/s)	0,3	0,5	0,8	1,2	1,8	2,6
Flow rate max. (l/s)	4,7	8,0	12	18	29	42
Exceptional (l/s)	6,9	11	17	27	42	61

Weights and dimensions

DN (mm)	50	65	80	100	125	150
A (mm)	230	290	310	350	400	480
B (mm)	83	93	100	110	135	150
C (mm)	280	320	350	420	590	690
Weight (Kg)	12	19	24	34	56	74

Values are approximate, consult PF service for more details.

Head loss coefficient

Kv coefficient representing the flow rate which is flowing through the valve fully open, and producing a head loss of 1 bar.

Cavitation chart

- A: Recommended working conditions;
- B: Incipient cavitation;
- C: Damage cavitation.

Ensure that the working point, obtained connecting upstream (y axis) and downstream (x axis) pressure conditions, falls on the A zone with the smallest valve to meet the required flow.

The chart is to be used for valves modulating with an opening percentage between 35-40% at standard water temperature and elevation below 300 m. For continuous pressure reduction the maximum allowed Δp shall not exceed 24 bar.

Reduced pressure falloff

The plot is showing the reduced pressure falloff that occurs through the valve when the flow increases. Ensure that the operating conditions fall on the area depicted in blue for the recommended fluid flow velocity through the valve.

Standard

Certified and tested in compliance with EN 1074/5.
 Flanges according to EN 1092/2. Epoxy painting applied through fluidized bed technology blue RAL 5005.
 Changes on flanges and painting on request.

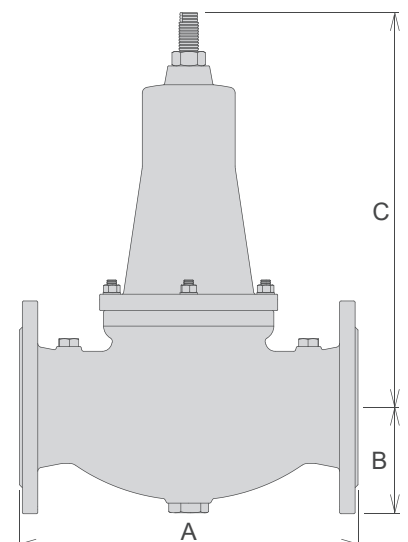

Technical details

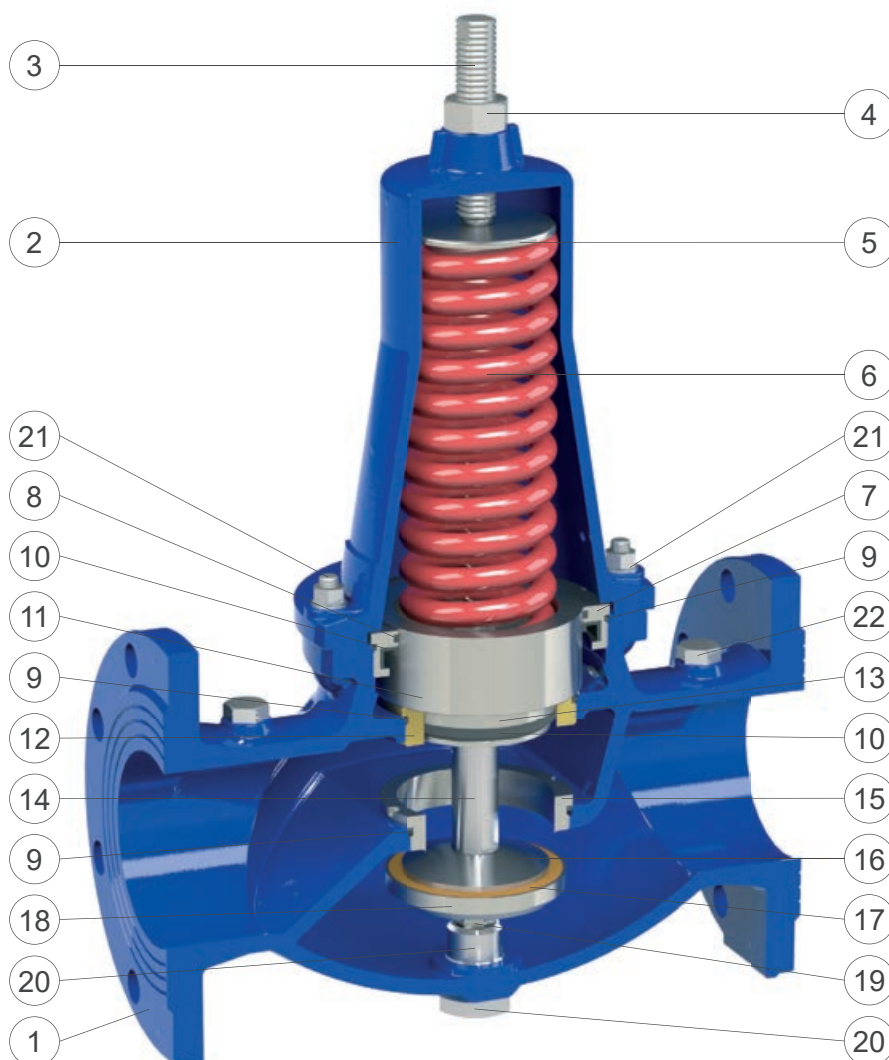

N.	Component	Standard material	Optional
1	Body	ductile cast iron GJS 450-10	
2	Cap	ductile cast iron GJS 450-10	
3	Driving screw	stainless steel AISI 304	stainless steel AISI 316
4	Nut	stainless steel AISI 304	stainless steel AISI 316
5	Spring guide	stainless steel AISI 303	stainless steel AISI 316
6	Spring	spring painted steel 52SiCrNi5	
7	Main bush	stainless steel AISI 304	stainless steel AISI 316
8	Sliding ring	PTFE	
9	O-rings	NBR	EPDM/Viton
10	Gasket	NBR	EPDM/Viton
11	Upper piston	s.s. AISI 303 (bronze CuSn5Zn5Pb5 for DN 125-150)	stainless s. AISI 303/316
12	Lower ring	bronze CuSn5Zn5Pb5	stainless s. AISI 304/316
13	Lower piston	stainless steel AISI 303	stainless steel AISI 316
14	Spacer	stainless steel AISI 303	stainless steel AISI 316
15	Obturator sealing seat	stainless steel AISI 304	stainless steel AISI 316
16	Gasket support	stainless steel AISI 303	stainless steel AISI 316
17	Plane gasket	NBR (polyurethane for PN 25-40)	
18	Gasket holder	stainless steel AISI 303	stainless steel AISI 316
19	Guiding shaft	stainless steel AISI 303	stainless steel AISI 316
20	Driving tap	stainless steel AISI 303	stainless steel AISI 316
21	Studs, nuts and washers	stainless steel AISI 304	stainless steel AISI 316
22	Taps for pressure gauges	stainless steel AISI 316	

The list of materials and components is subject to changes without notice.

Spare parts breakdown

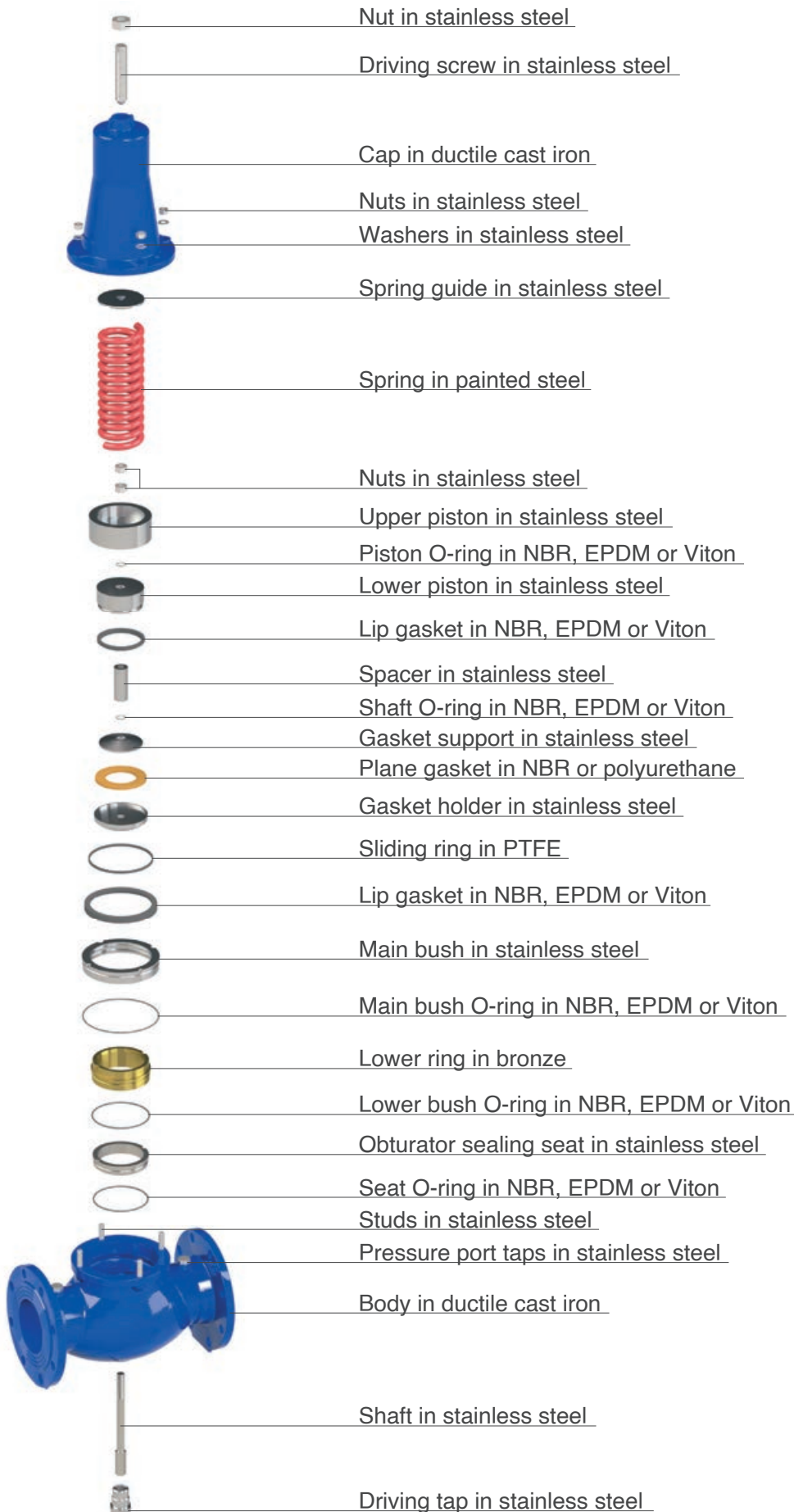

Installation layout

The installation layout of the PF pressure reducer W-VAL includes a filter upstream to prevent the entrance of debris, stones and particles likely to damage the internal components, and sectioning devices. A by-pass line, with one more W-VAL, is highly recommended to ensure water supply during maintenance. PF anti-slam combination air valves WAVE 3S-AWH series are needed before and after the installation as well as PF pressure relief valve WR/AM downstream, to discharge possible increase in pressure.



Installation layout

The picture below shows the recommended installation layout of PF direct acting pressure reducer PF W-VAL HP installed on a line for level control applications, in combination with equilibrium ball float valve H-FLOAT. The reason is to prevent cavitation and potential damages arising from high static values acting on it once the level has reached the maximum value, with the valve on its fully closed position.

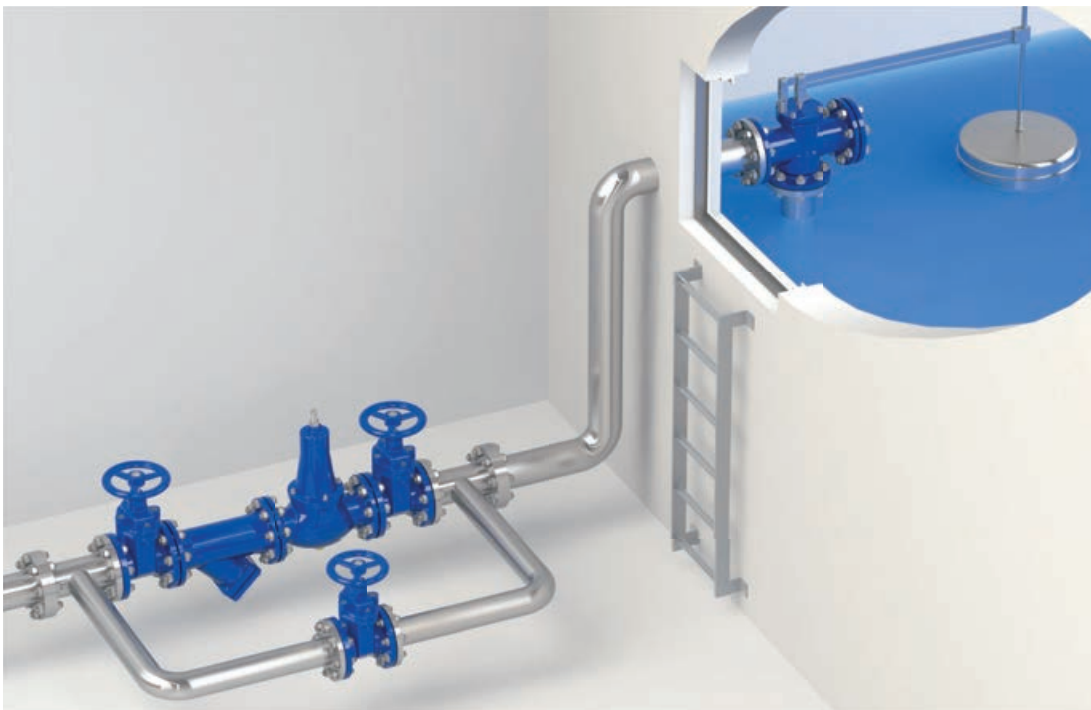

Downstream pressure reducer-stabilizer Mod. W-VAL LP

The PF direct acting pressure reducing valve Mod. W-VAL LP reduces and stabilizes the downstream pressure to a constant value, regardless of flow rate and upstream pressure variations. It can be used for water and fluids in general.



Technical features and benefits

- Flanged version DN 50-150.
- Upstream and downstream pressure balanced, to stabilize the downstream pressure to a pre-set (and adjustable) value regardless of upstream pressure variations without creating unwanted upsurges.
- Ductile cast iron for body and cap, piston in stainless steel, seat in stainless steel as well as bolts and nuts.
- Diaphragm in polyamide nylon reinforced fabric.
- Innovative self cleaning piston technology to improve performances reducing maintenance operations.
- Mobile block composed of components in gun metal/stainless steel obtained by CNC to ensure the maximum accuracy and sliding precision, this is to avoid friction and unexpected leakage.
- Upstream/downstream pressure outlets for gauges.
- Large expansion chamber to reduce noise and to provide an excellent resistance to cavitation.
- Epoxy powder applied using FBT technology.

Applications

- Water distribution systems.
- Buildings and civil installations.
- Irrigations.
- Cooling systems.
- Fire protection systems and in general whenever the pressure reduction has to be ensured.

Operating principle

The operating principle of W-VAL LP is based on a piston sliding into a ring in stainless steel/bronze of different diameters. This ring, tightly connected to the body, and the diaphragm form a watertight chamber also known as the compensation chamber which is necessary for the accuracy and stability of the valve.

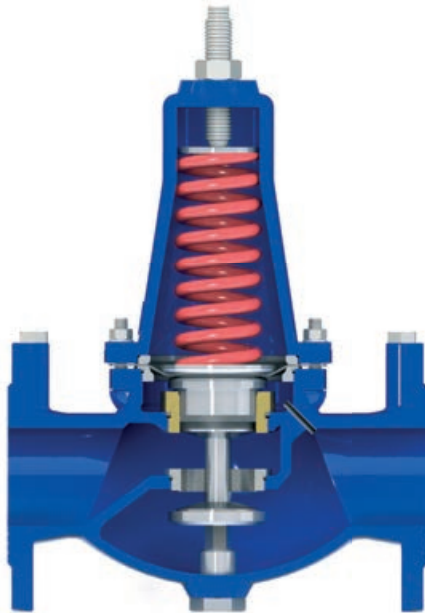

Valve normally open

Without any pressure the W-VAL LP is a normally open valve, where the piston is kept pushed down by the force of the spring located in the cover and acting above the diaphragm.

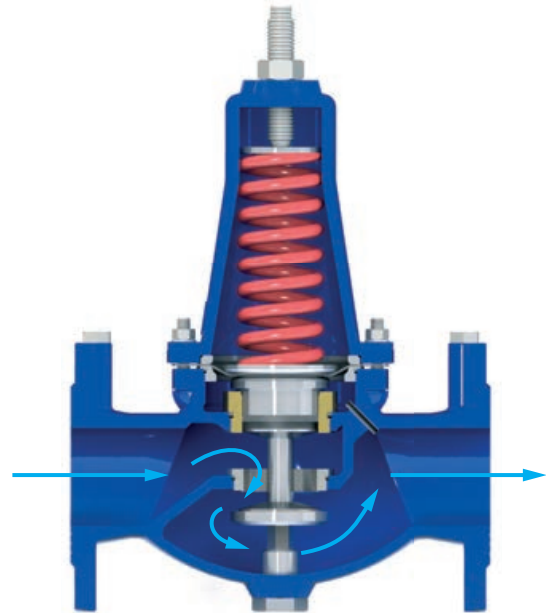

Valve fully open

During working conditions, should the downstream pressure drop below the valve's set point obtained by the compression of the spring, the W-VAL LP will open completely allowing the full passage.

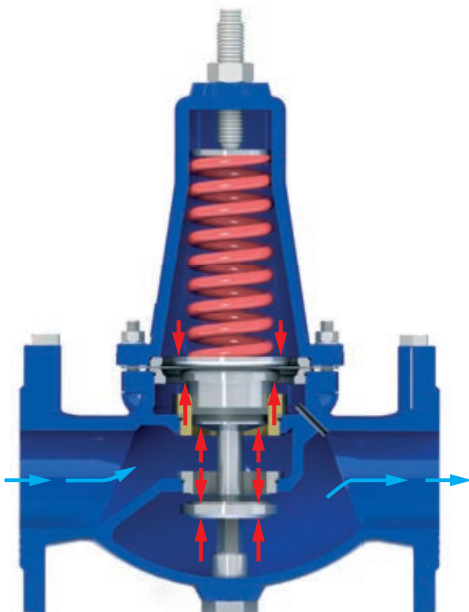

Valve modulating

Should the downstream pressure rise above the valve's set point the resultant of the force obtained by the downstream pressure, acting on the diaphragm through the compensation chamber against the spring pushing downwards, will move the obturator producing the required head loss to modulate and stabilize the downstream pressure.

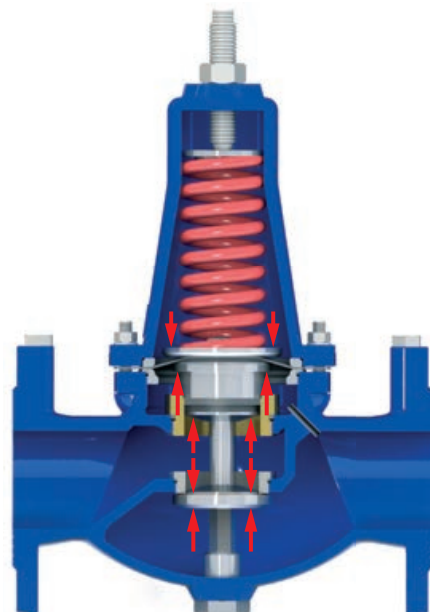

Valve fully closed (static conditions)

Should the water supply be interrupted from downstream the system will work in static conditions, the W-VAL LP will maintain and stabilize the required pressure even with no flow thanks to the pressure balanced technology and compensation chamber.

Technical data

DN mm	50	65	80	100	125	150
Kv (m ³ /h)/bar	20	47	72	116	147	172

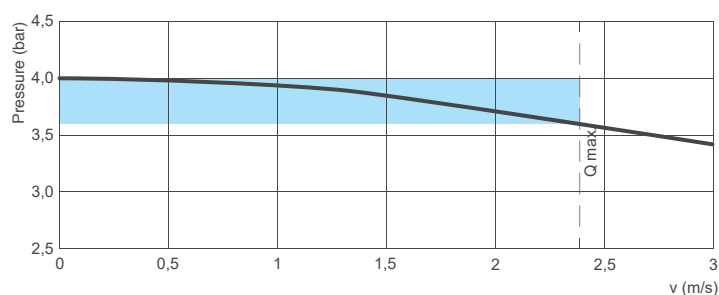
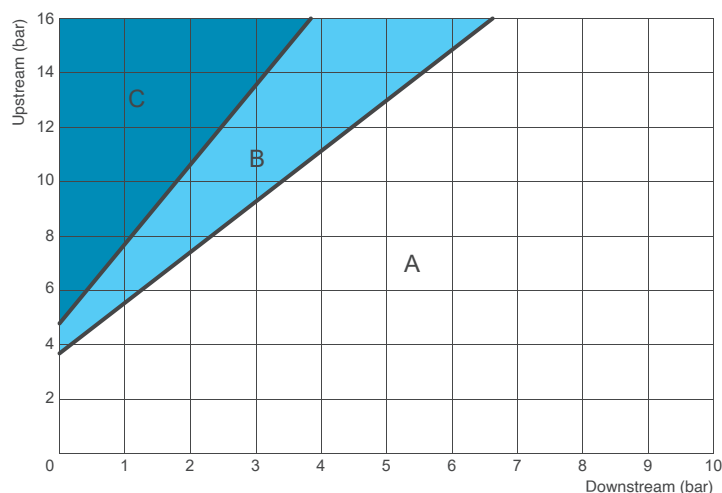

Working conditions

Treated water with a maximum temperature of 70°C.
 Upstream pressure (inlet): maximum 16 bar.
 Downstream pressure (outlet): adjustable from 1,5 to 5 bar.
 Different values on request.

Recommended flow rate

DN (mm)	50	65	80	100	125	150
Flow rate min. (l/s)	0,3	0,5	0,8	1,2	1,8	2,6
Flow rate max. (l/s)	5,1	8,6	13	20	31	45
Exceptional (l/s)	6,9	11	17	27	42	61

Weights and dimensions

DN (mm)	50	65	80	100	125	150
A (mm)	230	290	310	350	400	480
B (mm)	83	93	100	110	135	150
C (mm)	280	320	350	420	590	690
Weight (Kg)	12	19	24	34	56	74

Values are approximate, consult PF service for more details.

Head loss coefficient

Kv coefficient representing the flow rate which is flowing through the valve fully open, and producing a head loss of 1 bar.

Cavitation chart

- A: Recommended working conditions;
- B: Incipient cavitation;
- C: Damage cavitation.

Ensure that the working point, obtained connecting upstream (y axis) and downstream (x axis) pressure conditions, falls on the A zone with the smallest valve to meet the required flow.

The chart is to be used for valves modulating with an opening percentage between 35-40% at standard water temperature and elevation below 300 m. For continuous pressure reduction the maximum allowed Δp shall not exceed 24 bar.

Reduced pressure falloff

The plot is showing the reduced pressure falloff that occurs through the valve when the flow increases. Ensure that the operating conditions fall on the area depicted in blue for the recommended fluid flow velocity through the valve.

Standard

Certified and tested in compliance with EN 1074/5.
 Flanges according to EN 1092/2. Epoxy painting applied through fluidized bed technology blue RAL 5005.
 Changes on flanges and painting on request.

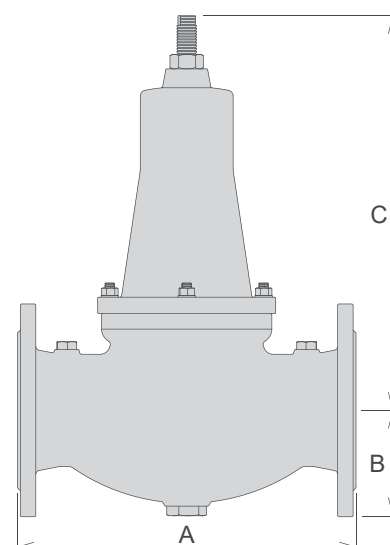

Technical details

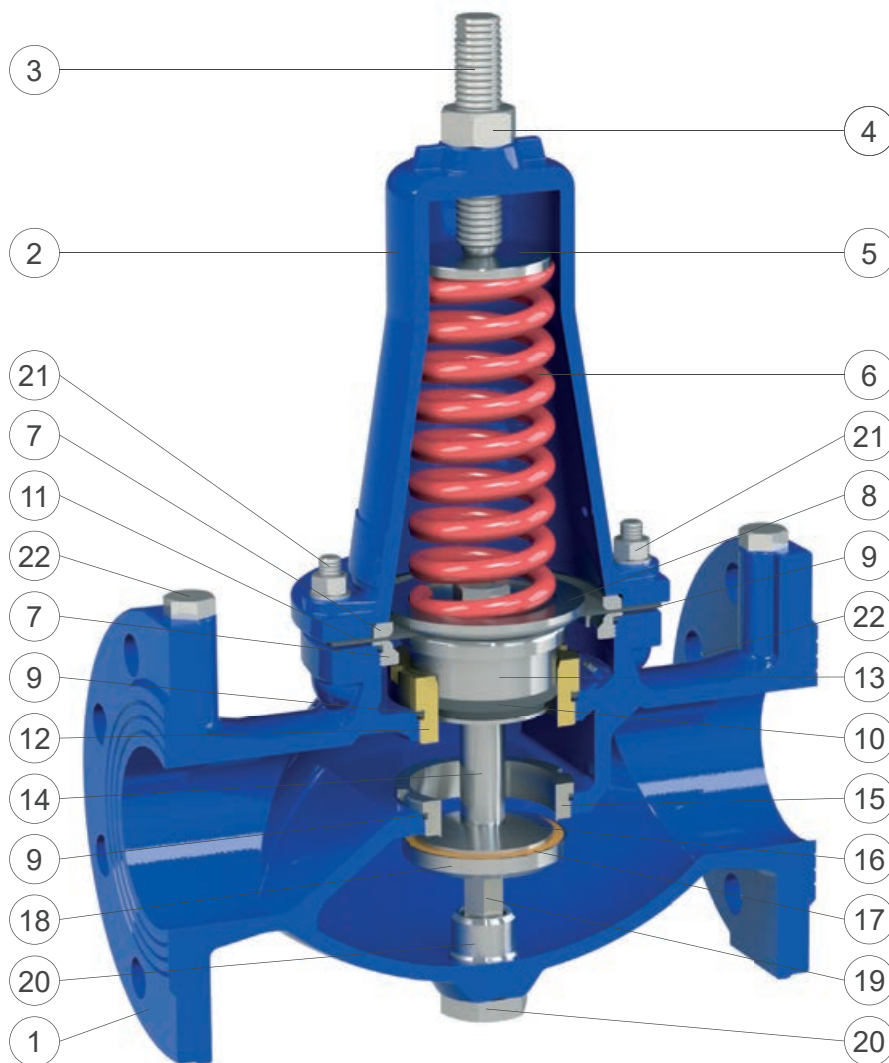

N.	Component	Standard material	Optional
1	Body	ductile cast iron GJS 450-10	
2	Cap	ductile cast iron GJS 450-10	
3	Driving screw	stainless steel AISI 304	stainless steel AISI 316
4	Nut	stainless steel AISI 304	stainless steel AISI 316
5	Spring guide	stainless steel AISI 303	stainless steel AISI 316
6	Spring	spring painted steel 52SiCrNi5	
7	Upper and lower compression rings	stainless steel AISI 304	stainless steel AISI 316
8	Upper flat	painted steel	stainless s. AISI 304/316
9	O-rings	NBR	EPDM/Viton
10	Gasket	NBR	EPDM/Viton
11	Diaphragm	EPDM-Nylon	neoprene
12	Lower ring	bronze CuSn5Zn5Pb5	stainless s. AISI 304/316
13	Piston	stainless steel AISI 303	stainless steel AISI 316
14	Spacer	stainless steel AISI 303	stainless steel AISI 316
15	Obturator sealing seat	stainless steel AISI 304	stainless steel AISI 316
16	Gasket support	stainless steel AISI 303	stainless steel AISI 316
17	Plane gasket	NBR	
18	Gasket holder	stainless steel AISI 303	stainless steel AISI 316
19	Guiding shaft	stainless steel AISI 303	stainless steel AISI 316
20	Driving tap	stainless steel AISI 303	stainless steel AISI 316
21	Studs, nuts and washers	stainless steel AISI 304	stainless steel AISI 316
22	Taps for pressure gauges	stainless steel AISI 316	

The list of materials and components is subject to changes without notice.

Downstream pressure reducer-stabilizer in stainless steel - Mod. W-VAL TH

The PF direct acting pressure reducing valve Mod. W-VAL TH reduces and stabilizes the downstream pressure to a constant value, regardless of flow rate and upstream pressure variations. It can be used for water, air and fluids in general with a maximum working pressure of 64 bar.



Technical features and benefits

- Entirely manufactured in stainless steel machined from a solid bar.
- Upstream and downstream pressure balanced, to stabilize the downstream pressure to a pre-set (and adjustable) value regardless of upstream pressure variations without creating unwanted upsurges.
- Innovative self cleaning piston technology to improve performances reducing maintenance operations.
- Mobile block composed of stainless steel internals obtained by CNC to ensure the maximum accuracy and sliding precision, this is to avoid friction and unexpected leakage.
- Excellent resistance to cavitation and aggressive environments thanks to the design and the use of gaskets in special materials.
- Wide flow range and downstream pressure regulation values with long lasting performances compared to other solution in brass or different materials.

Applications

- Water distribution systems for high pressure ratio.
- Buildings and civil installations whenever stainless steel is required or advised for project aspects.
- Demineralized water and bottling plants.
- Industry and cooling systems.
- Mining and refineries.

Operating principle

The operating principle of W-VAL TH, upstream pressure balanced, is based on a piston sliding into two rings of different diameters. These rings form a watertight chamber, also known as the compensation chamber, which is necessary for the accuracy and stability of the valve.



Valve normally open

Without any pressure the W-VAL TH is a normally open valve, where the piston is kept pushed down by the force of the spring located in the cover.

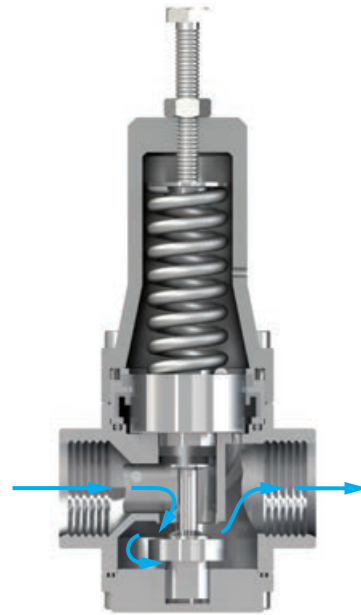

Valve fully open

During working conditions, should the downstream pressure drop below the valve's set point obtained by the compression of the spring, the W-VAL TH will open completely allowing the full passage.

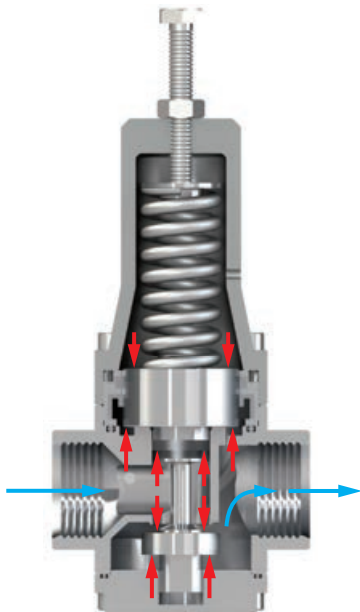

Valve modulating

Should the downstream pressure rise above the valve's set point the resultant of the force obtained by the downstream pressure acting on the mobile block and the compensation chamber against the spring pushing downwards, will move the obturator producing the required head loss to modulate and stabilize the downstream pressure.

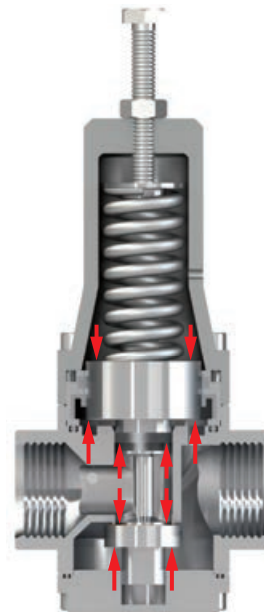

Valve fully closed (static conditions)

Should the water supply be interrupted from downstream the system will go in static conditions, the W-VAL TH will maintain and stabilize the required pressure even with no flow thanks to the pressure balanced technology and compensation chamber.

Technical data

Thread (inches)	1/2"	1"	1" 1/2	2"
Kv (m ³ /h)/bar	2,9	7,2	10,8	21

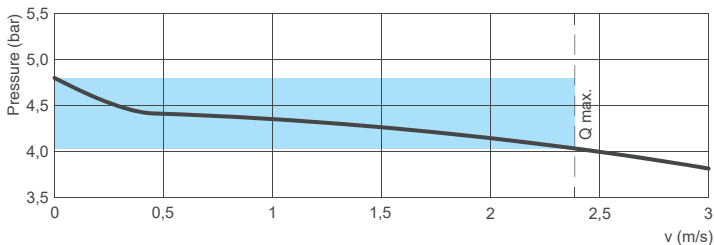
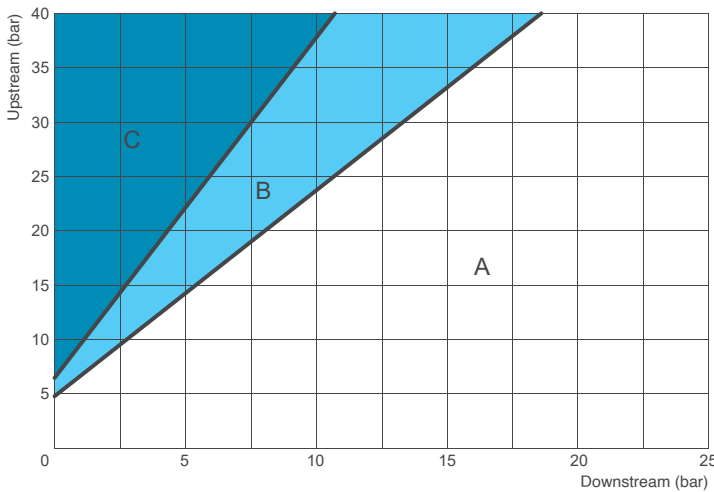

Working conditions

Treated water with a maximum temperature of 70°C (120°C on request).

Upstream pressure (inlet): maximum 40/64 bar.

Higher downstream pressure values on request.

Recommended flow rate

Thread (inches)	1/2"	1"	1" 1/2	2"
Flow rate min. (l/s)	0,02	0,05	0,11	0,30
Flow rate max. (l/s)	0,35	0,98	2,20	4,45
Exceptional (l/s)	0,39	1,50	2,80	6,90

Springs pressure ranges

Thread (inches)	1/2"	1"	1" 1/2	2"
Spring pressure (bar)	1,5-10	1,5-10	1,5-7	1,5-6
	2-20	2-20	2-15	5-12

Weights and dimensions

Thread inches	A mm	B mm	C mm	D mm	Weight Kg
1/2"	53	- -	108	25	1,0
1"	90	CH 41	170	45	2,1
1" 1/2	110	CH 55	205	50	2,8
2"	152	CH 70	290	60	5,9

Values are approximate, consult PF service for more details.

Head loss coefficient

Kv coefficient representing the flow rate which is flowing through the valve fully open producing a head loss of 1 bar.

Cavitation chart

- A: Recommended working conditions;
- B: Incipient cavitation;
- C: Damage cavitation.

Ensure that the working point, obtained connecting upstream (y axis) and downstream (x axis) pressure conditions, falls on the A zone with the smallest valve to meet the required flow.

The chart is to be used for valves modulating with an opening percentage between 35-40% at standard water temperature and elevation below 300 m. For continuous pressure reduction the maximum allowed Δp shall not exceed 24 bar, for higher values contact PF assistance.

Reduced pressure falloff

The plot is showing the reduced pressure falloff that occurs through the valve when the flow increases. Ensure that the operating conditions fall on the area depicted in blue for the recommended fluid flow velocity through the valve.

Standard

Certified and tested in compliance with EN 1074/5.

Threaded BSP connections.

Variations on the thread available on request.

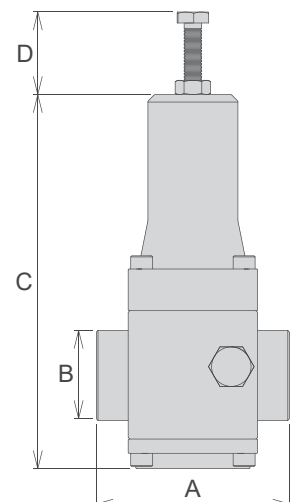

Technical details

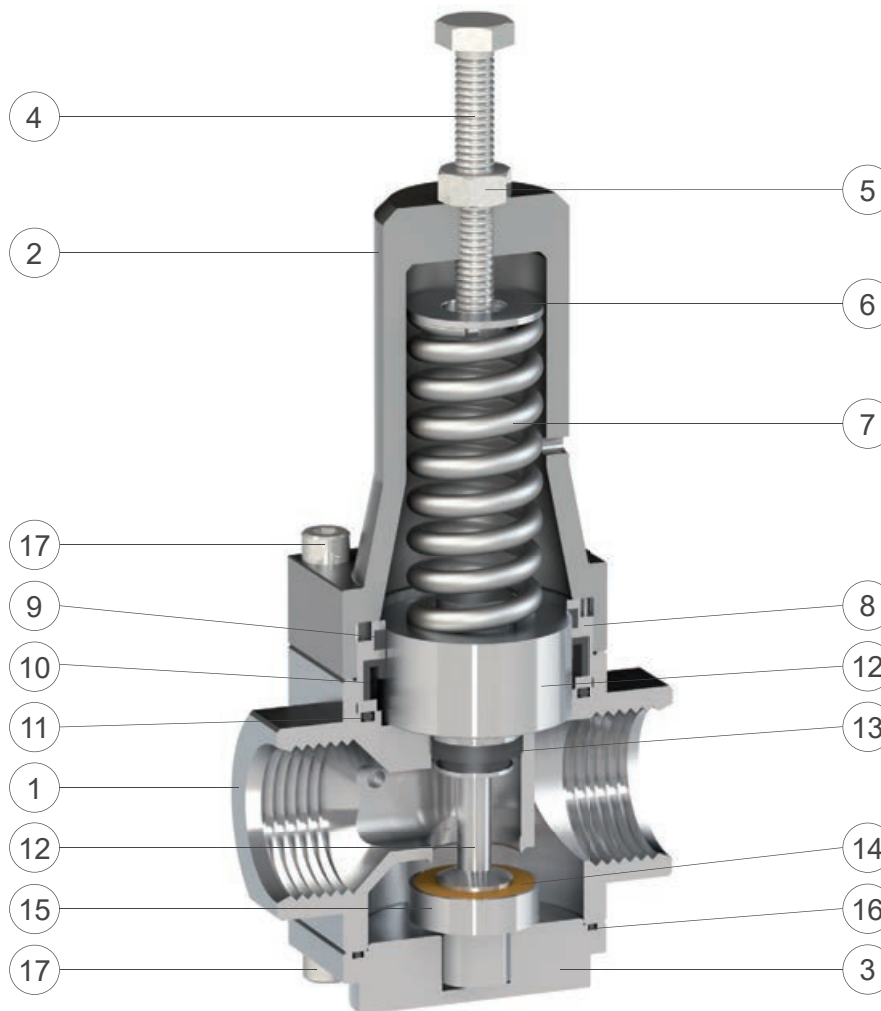

N.	Component	Standard material	Optional
1	Body	s.s. AISI 303 (1"-1" 1/2), AISI 304 (1/2"-2")	stainless steel AISI 316
2	Cap	nickel-plated aluminium S11	stainless steel AISI 316
3	Driving tap	s.s. AISI 303 (1"-1" 1/2), AISI 304 (1/2"-2")	stainless steel AISI 316
4	Driving screw	stainless steel AISI 304	stainless steel AISI 316
5	Nut	stainless steel AISI 304	stainless steel AISI 316
6	Spring guide	stainless steel AISI 304	stainless steel AISI 316
7	Spring	s.s. AISI 302 (painted steel 52SiCrNi5 for 2")	
8	Main bush	stainless steel AISI 304	stainless steel AISI 316
9	Sliding ring	PTFE	
10	Upper gasket	NBR	EPDM/Viton
11	O-ring	NBR	EPDM/Viton
12	Piston	stainless steel AISI 303	stainless steel AISI 316
13	Lower gasket	NBR	EPDM/Viton
14	Plane gasket	polyurethane	
15	Obturator guide	stainless steel AISI 303	stainless steel AISI 316
16	Tap O-ring	NBR	EPDM/Viton
17	Screws	stainless steel AISI 304	stainless steel AISI 316

The list of materials and components is subject to changes without notice.

Downstream pressure reducer-stabilizer for high pressure - Mod. W-FLUX

The PF direct acting pressure reducing valve Mod. W-FLUX reduces and stabilizes the downstream pressure to a constant value, regardless of flow rate variations. It can be used for water, air and fluids in general up to a temperature of 70° C and a maximum pressure of 64 bar.



Technical features and benefits

- Flanged version DN 50-150 PN 64 rated.
- Ductile cast iron cap and body in electro-welded steel, piston and mobile block in stainless steel.
- Upstream and downstream pressure balanced, to stabilize the downstream pressure to a pre-set (and adjustable) value regardless of upstream pressure variations without creating unwanted upsurges.
- Innovative self cleaning piston technology (patent pending) to improve performances reducing maintenance operations.
- Mobile block composed of three components in gun metal/stainless steel obtained by CNC to ensure the maximum accuracy and sliding precision, this is to avoid friction and unexpected leakage.
- Upstream and downstream pressure outlets for gauges.
- Large expansion chamber and materials providing an excellent resistance to cavitation and long lasting performances.
- Epoxy powder applied using FBT technology.

Applications

- Water distribution systems for high pressure ratio.
- Mining.
- Industry and cooling systems.
- Dams and power plants.

Operating principle

The operating principle of W-FLUX is based on a piston sliding into two rings in stainless steel/bronze of different diameters. These rings, tightly connected to the body, form a watertight chamber also known as the compensation chamber which is necessary for the accuracy and stability of the valve.

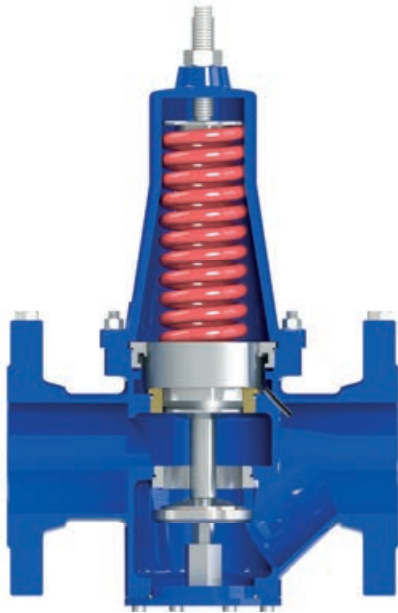

Valve normally open

Without any pressure the W-FLUX is a normally open valve, where the piston is kept pushed down by the force of the spring located in the cover.

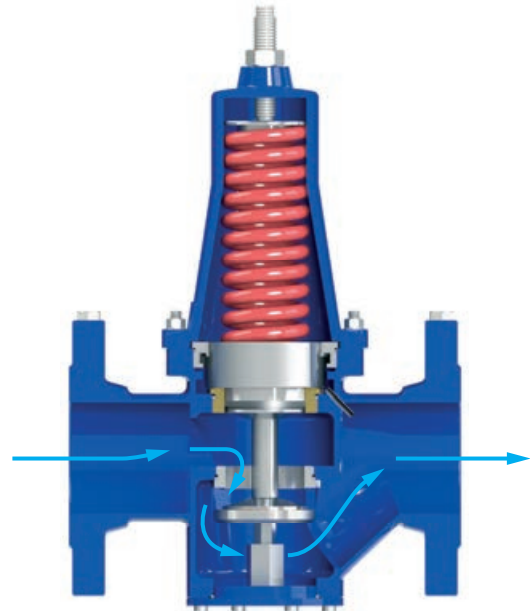

Valve fully open

During working conditions, should the downstream pressure drop below the valve's set point obtained by the compression of the spring, the W-FLUX will open completely allowing the full passage.

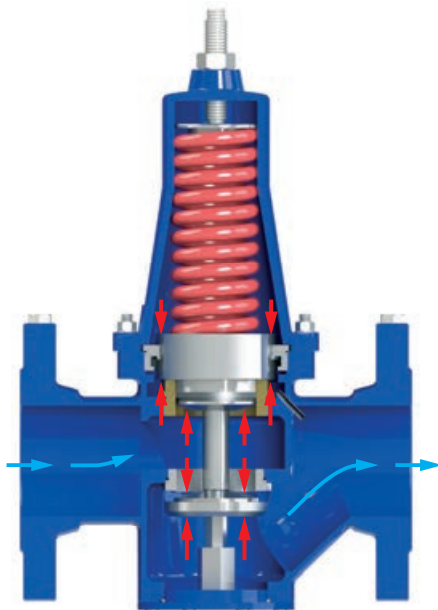

Valve modulating

Should the downstream pressure rise above the valve's set point the resultant of the force obtained by the downstream pressure, acting on the mobile block and the compensation chamber against the spring pushing downwards, will move the obturator producing the required head loss to modulate and stabilize the downstream pressure.

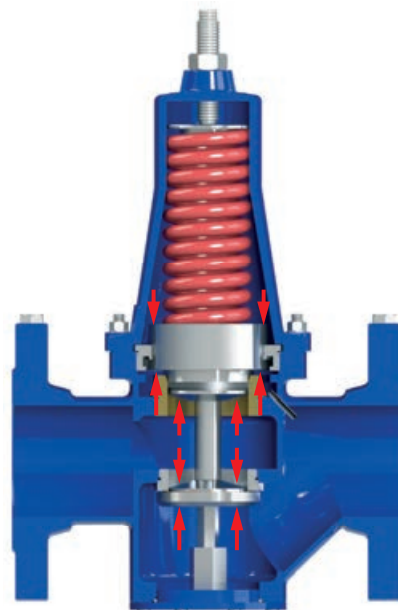

Valve fully closed (static conditions)

Should the water supply be interrupted from downstream the system will go in static conditions, the W-FLUX will maintain and stabilize the required pressure even with no flow thanks to the pressure balanced technology and compensation chamber.

Technical data

DN (mm)	50	80	100	150
Kv (m ³ /h)/bar	18	63	98	147

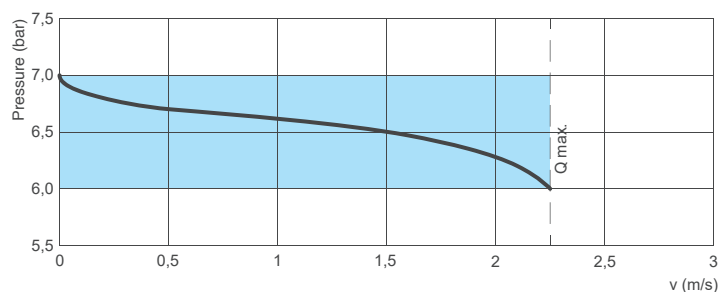
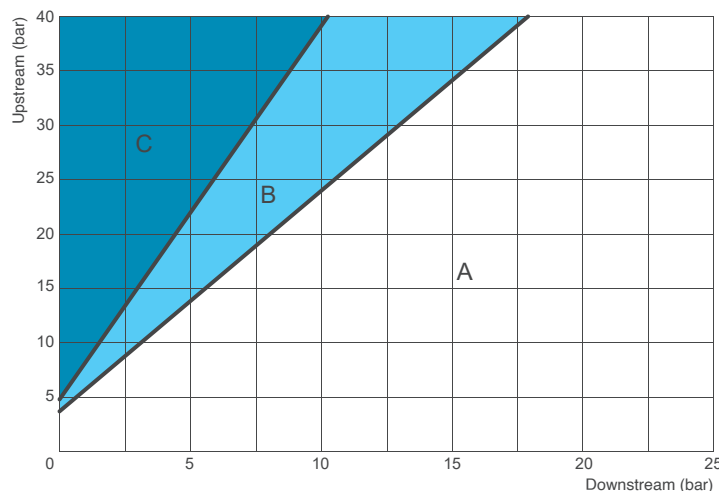

Working conditions

Treated water with a maximum temperature of 70°C.
 Upstream pressure (inlet): maximum 64 bar.
 Downstream pressure (outlet): standard from 1,5 to 6 bar or from 5 to 12 bar. Higher values on request.

Recommended flow rate

DN (mm)	50	80	100	150
Flow rate min. (l/s)	0,3	0,8	1,2	2,6
Flow rate max. (l/s)	3,9	10	15	40
Exceptional (l/s)	6,9	17	27	61

Weights and dimensions

DN (mm)	50	80	100	150
A (mm)	230	310	350	480
B (mm)	90	108	126	172
C (mm)	240	340	400	500
Weight (Kg)	15	29	40	90

Values are approximate, consult PF service for more details.

Head loss coefficient

Kv coefficient representing the flow rate which is flowing through the valve fully open producing a head loss of 1 bar.

Cavitation chart

- A: Recommended working conditions;
- B: Incipient cavitation;
- C: Damage cavitation.

Ensure that the working point, obtained connecting upstream (y axis) and downstream (x axis) pressure conditions, falls on the A zone with the smallest valve to meet the required flow.

The chart is to be used for valves modulating with an opening percentage between 35-40% at standard water temperature and elevation below 300 m. For continuous pressure reduction the maximum allowed Δp shall not exceed 24 bar, for higher values contact PF assistance.

Reduced pressure falloff

The plot is showing the reduced pressure falloff that occurs through the valve when the flow increases. Ensure that the operating conditions fall on the area depicted in blue for the recommended fluid flow velocity through the valve.

Standard

Certified and tested in compliance with EN 1074/5.
 Flanges according to EN 1092/2. Epoxy painting applied through fluidized bed technology blue RAL 5005.
 Changes on flanges and painting on request.

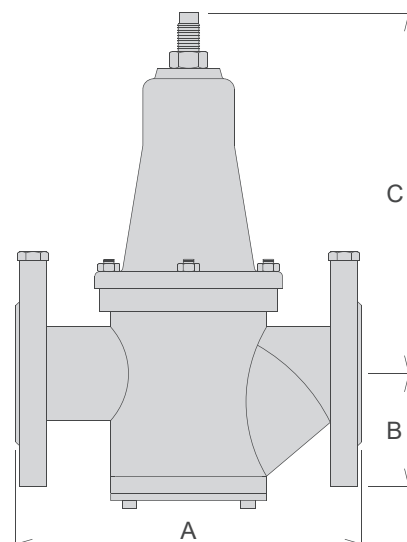

Technical details

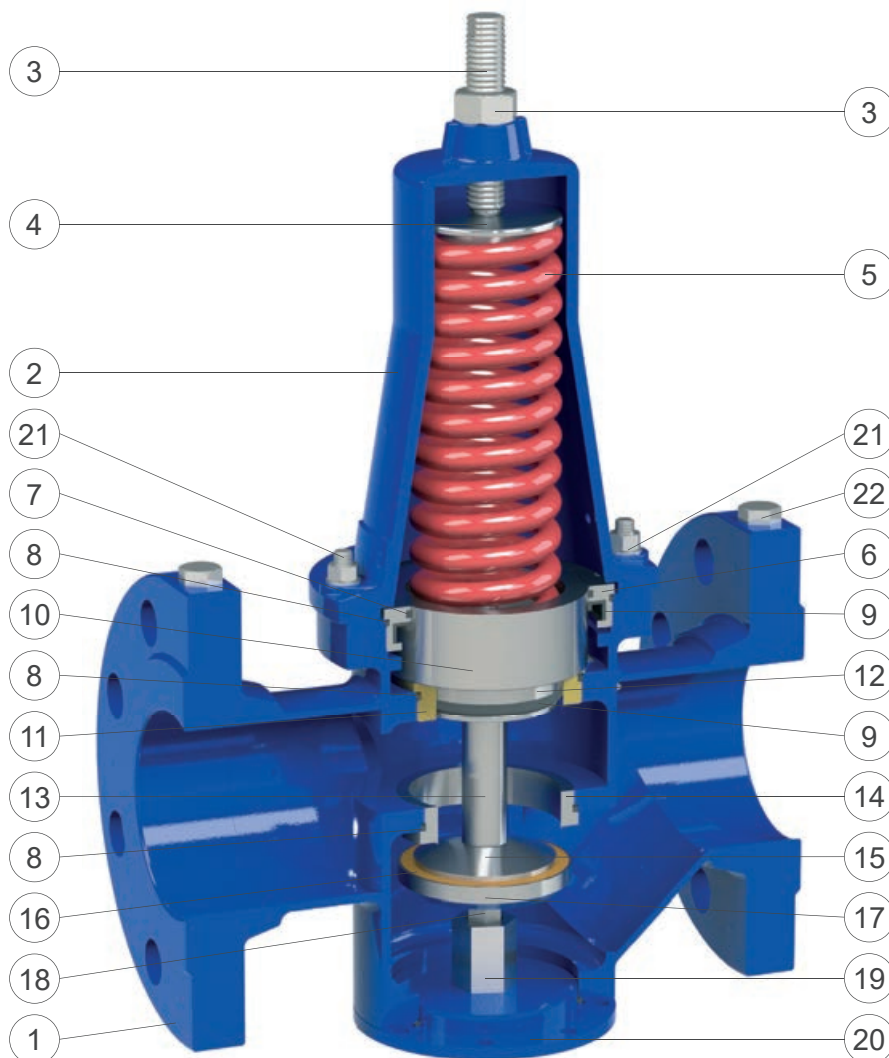

N.	Component	Standard material	Optional
1	Body	painted steel	
2	Cap	ductile cast iron GJS 450-10	
3	Driving screw and nut	stainless steel AISI 304	stainless steel AISI 316
4	Spring guide	stainless steel AISI 303	stainless steel AISI 316
5	Spring	spring painted steel 52SiCrNi5	
6	Main bush	stainless steel AISI 304	stainless steel AISI 316
7	Sliding ring	PTFE	
8	O-rings	NBR	EPDM/Viton
9	Gasket	NBR	EPDM/Viton
10	Upper piston	s.s. AISI 303 (bronze CuSn5Zn5Pb5 for DN 150)	stainless s. AISI 303/316
11	Lower reinforcements	bronze CuSn5Zn5Pb5	stainless s. AISI 304/316
12	Lower piston	stainless steel AISI 303	stainless steel AISI 316
13	Spacer	stainless steel AISI 303	stainless steel AISI 316
14	Obturator sealing seat	stainless steel AISI 304	stainless steel AISI 316
15	Gasket support	stainless steel AISI 303	stainless steel AISI 316
16	Plane gasket	polyurethane	
17	Obturator guide	stainless steel AISI 303	stainless steel AISI 316
18	Guiding shaft	stainless steel AISI 303	stainless steel AISI 316
19	Driving tap	stainless steel AISI 303	stainless steel AISI 316
20	Lower tap	painted steel	
21	Studs, nuts and washers	stainless steel AISI 304	stainless steel AISI 316
22	Taps for pressure gauges	stainless steel AISI 316	

The list of materials and components is subject to changes without notice.

Spare parts breakdown

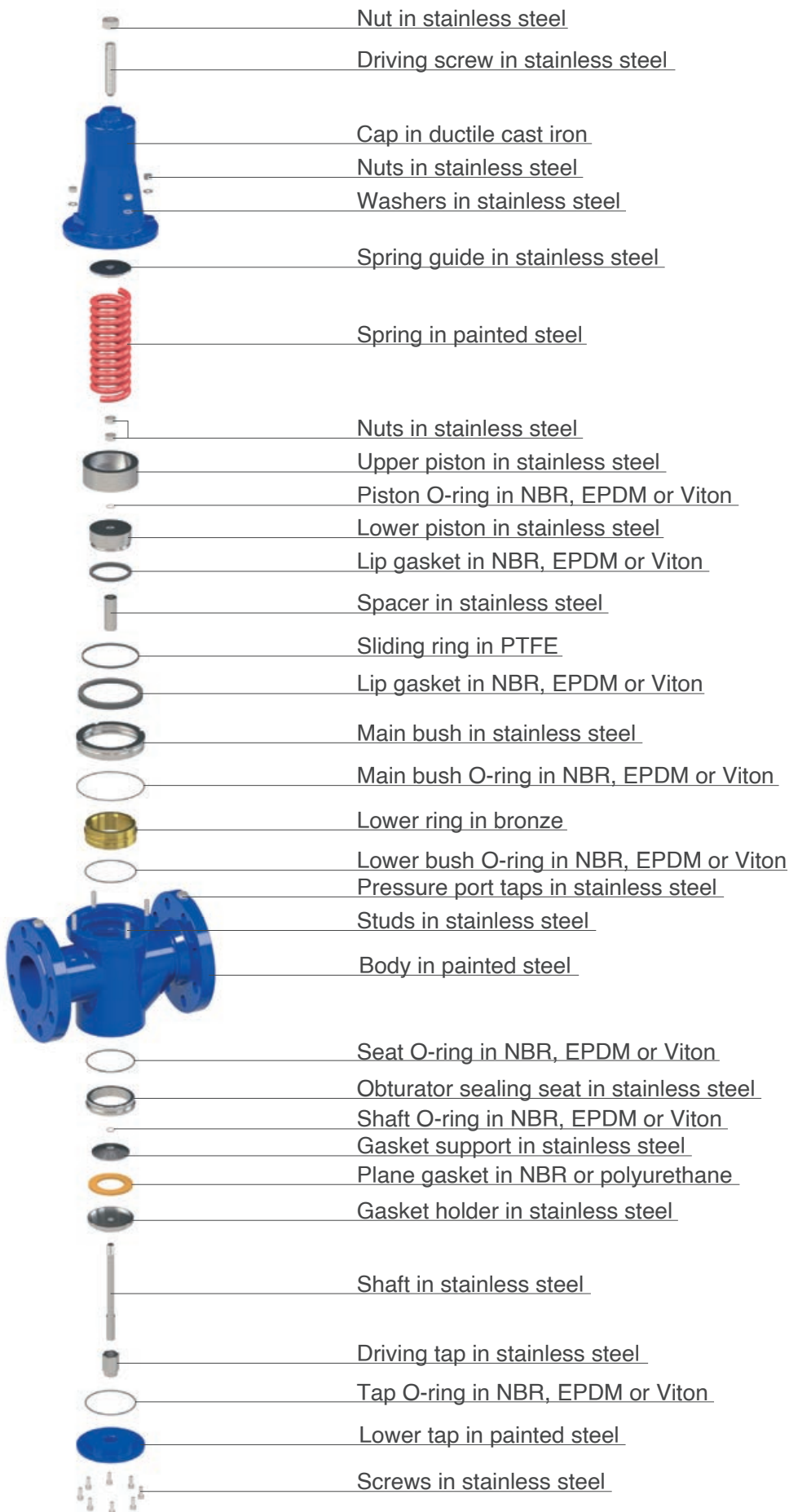

Installation layout

The installation layout of the PF direct acting pressure reducer W-FLUX includes a strainer upstream to prevent the entrance of debris, stones and particles likely to damage the internal components, and sectioning devices needed for inspection and maintenance. PF anti-slam combination air valves WAVE 3S-AWH series are needed before and after the installation as well as PF direct acting pressure relief valve WR/AM located downstream, to discharge any possible increase in pressure.



Installation layout

The picture shows PF pressure reducers installed in series, case of two steps pressure reduction applications, with the first as W-FLUX (in carbon welded steel) followed by the W-VAL HP line in ductile cast iron. The idea is to avoid excessive pressure dissipation on the W-VAL HP with the potential for cavitation and wear. Direct acting pressure sustaining/relief valves are located between the two PRV and downstream of the second to prevent dangerous rise in pressure, as well as to avoid damages on the ductile cast iron unit.



Pressure relief/sustaining valve Mod. WR/AM

The PF direct acting upstream pressure relief/sustaining valve Mod. WR/AM automatically maintains and sustains a minimum pre-set upstream pressure, discharging any excess downstream, regardless of variations in demand and downstream pressure fluctuations.



Technical features and benefits

- Flanged version DN 50-150.
- Upstream pressure balanced, to stabilize and maintain the upstream pressure to a minimum pre-set (and adjustable) value regardless of demand and downstream pressure variations.
- Ductile cast iron for body and cap, piston in stainless steel, seat in stainless steel, guiding bush in stainless steel as well as bolts and nuts.
- Innovative self cleaning piston technology to improve performances reducing maintenance operations.
- Mobile block composed of three components in gun metal/stainless steel obtained by CNC to ensure the maximum accuracy and sliding precision, this is to avoid friction and unexpected leakage.
- Upstream/downstream pressure outlets for gauges.
- Large expansion chamber to reduce noise and to provide an excellent resistance to cavitation.
- Epoxy powder applied using FBT technology.

Applications

- Water distribution systems as a pressure relief/discharge valve.
- Fire fighting systems to discharge overpressure caused by pumps.
- Irrigation systems as an effective protection against water hammer and to prevent pumps from overload.
- Industrial plants, civil buildings and more.

Operating principle

The operating principle of WR/AM is based on a piston sliding into two rings in stainless steel/bronze of different diameters. These rings, tightly connected to the body, form a watertight chamber also known as the compensation chamber.

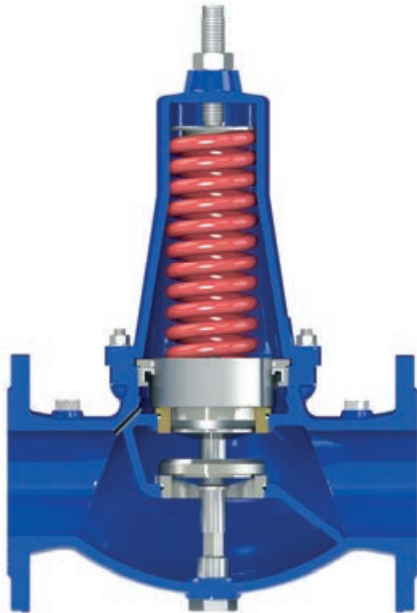

Valve normally closed

Without any incoming pressure the WR/AM is a normally closed valve, as shown in the picture, where the obturator is kept pushed down to the seat by the force of the spring.

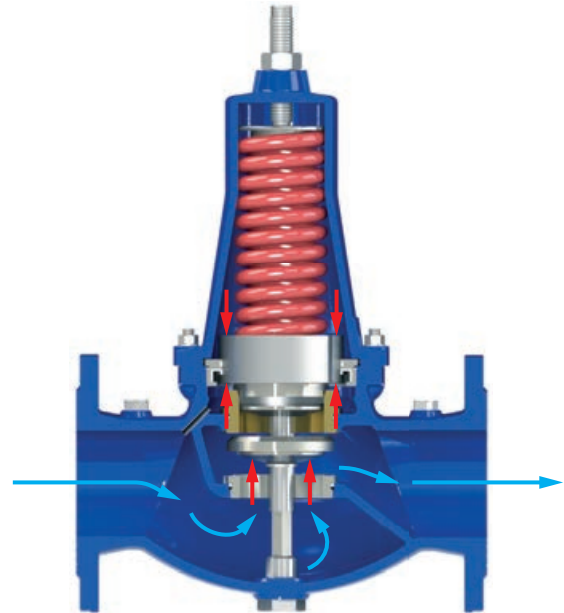

Valve fully open

Should the upstream pressure rise above the set point of the valve, obtained by the compression of the spring, the WR/AM will open completely allowing the full passage through the seat.

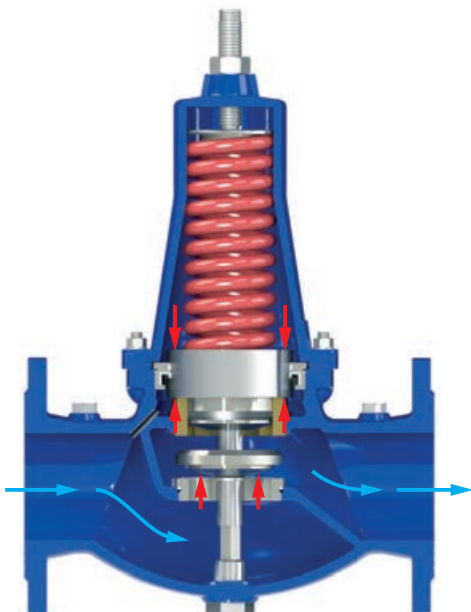

Valve modulating

Should the upstream pressure fluctuate around the valve's set point the obturator, thanks to the difference in force between the spring pushing downwards and the incoming pressure underneath and through the compensation chamber pushing upwards, will move throttling the flow through the seat in order to maintain the minimum required value.

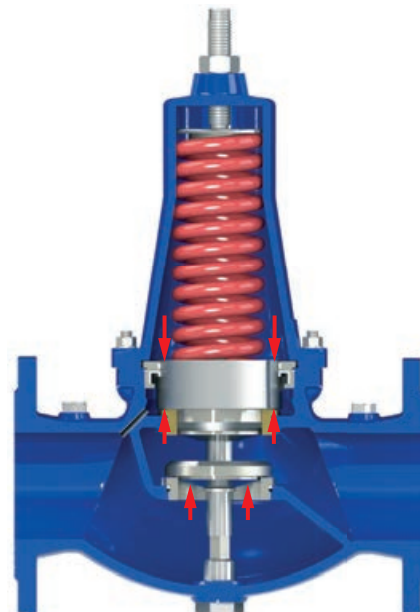

Valve fully closed (static conditions)

Should the water supply be interrupted from upstream pressure begins to drop, in this case the WR/AM will react immediately to maintain and stabilize the required upstream pressure even with no flow thanks to the pressure balanced technology, and compensation chamber.

Technical data

DN mm	50	65	80	100	125	150
Kv (m ³ /h)/bar	22	51	83	122	166	194

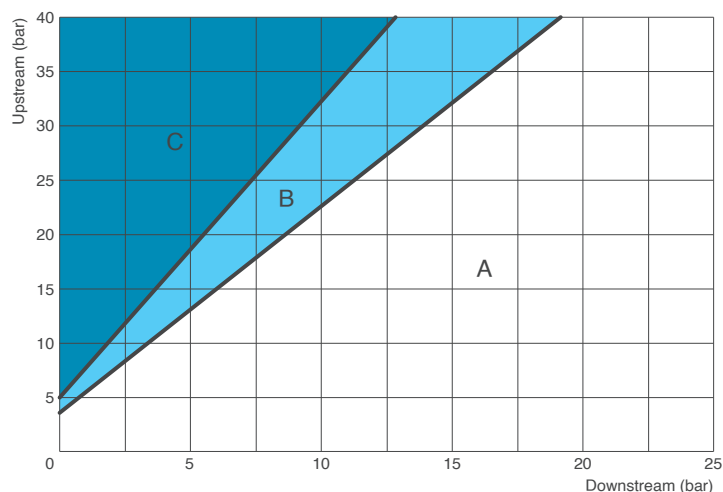

Head loss coefficient

Kv coefficient representing the flow rate which is flowing through the valve fully open producing a head loss of 1 bar.

Cavitation chart

- A: Recommended working conditions;
- B: Incipient cavitation;
- C: Damage cavitation.

Ensure that the working point, obtained connecting upstream (y axis) and downstream (x axis) pressure conditions, falls on the A zone with the smallest valve to meet the required flow. The chart is to be used for valves modulating with an opening percentage between 35-40% at standard water temperature and elevation below 300 m. For continuous pressure sustaining the maximum allowed Δp shall not exceed 17 bar. The pressure relief function will tolerate higher pressure differential values.

Working conditions

Treated water/air temperature: max. 70°C.

Maximum working pressure 40 bar.

Upstream pressure values: from 1,5 to 6 bar or from 5 to 12 bar.

Higher values on request.

Standard

Certified and tested in compliance with EN 1074/5.

Flanges according to EN 1092/2. Epoxy painting applied through fluidized bed technology blue RAL 5005.

Changes on flanges and painting on request.

Recommended flow rate - pressure sustaining

DN (mm)	50	65	80	100	125	150
Flow rate min. (l/s)	0,4	0,6	0,9	1,4	2,2	3,2
Flow rate max. (l/s)	4,5	7,6	11	18	28	40

Recommended flow rate - pressure relief

DN (mm)	50	65	80	100	125	150
Flow rate max. (l/s)	8,8	14	22	35	55	79

Weights and dimensions

DN (mm)	50	65	80	100	125	150
A (mm)	230	290	310	350	400	480
B (mm)	83	93	100	110	135	150
C (mm)	280	320	350	420	590	690
Weight (Kg)	12	19	24	34	56	74

Values are approximate, consult PF service for more details.

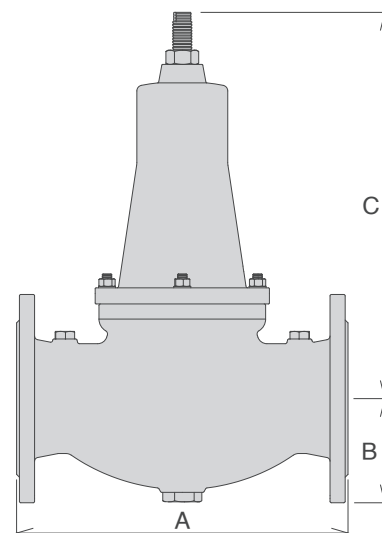

Technical details

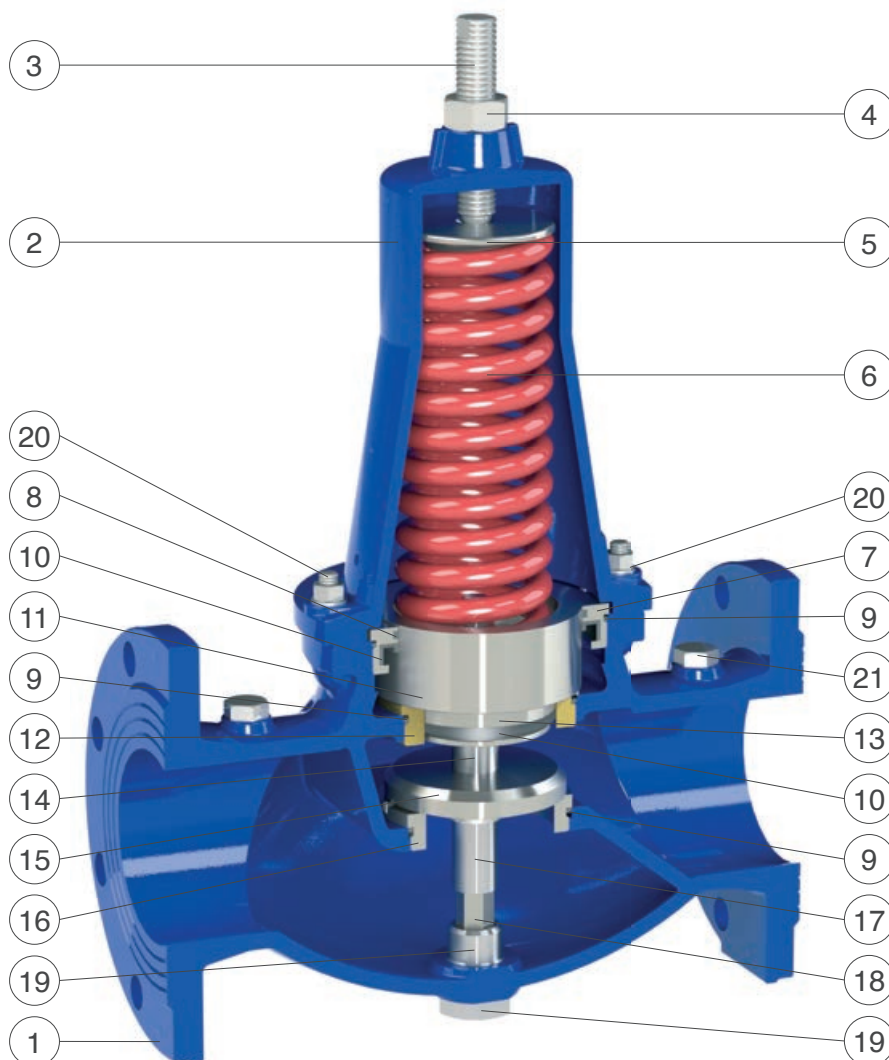

N.	Component	Standard material	Optional
1	Body	ductile cast iron GJS 450-10	
2	Cap	ductile cast iron GJS 450-10	
3	Driving screw	stainless steel AISI 304	stainless steel AISI 316
4	Nut	stainless steel AISI 304	stainless steel AISI 316
5	Spring guide	stainless steel AISI 303	stainless steel AISI 316
6	Spring	spring painted steel 52SiCrNi5	
7	Main bush	stainless steel AISI 304	stainless steel AISI 316
8	Sliding ring	PTFE	
9	O-rings	NBR	EPDM/Viton
10	Gasket	NBR	EPDM/Viton
11	Upper piston	s.s. AISI 303 (bronze CuSn5Zn5Pb5 for DN 125-150)	stainless s. AISI 303/316
12	Lower reinforcements	bronze CuSn5Zn5Pb5	stainless s. AISI 304/316
13	Lower piston	stainless steel AISI 303	stainless steel AISI 316
14	Central spacer	stainless steel AISI 303	stainless steel AISI 316
15	Obturator guide	stainless steel AISI 303	stainless steel AISI 316
16	Obturator sealing seat	stainless steel AISI 304	stainless steel AISI 316
17	Lower spacer	stainless steel AISI 303	stainless steel AISI 316
18	Guiding shaft	stainless steel AISI 303	stainless steel AISI 316
19	Driving tap	stainless steel AISI 303	stainless steel AISI 316
20	Studs, nuts and washers	stainless steel AISI 304	stainless steel AISI 316
21	Taps for pressure gauges	stainless steel AISI 316	

The list of materials and components is subject to changes without notice.

Spare parts breakdown

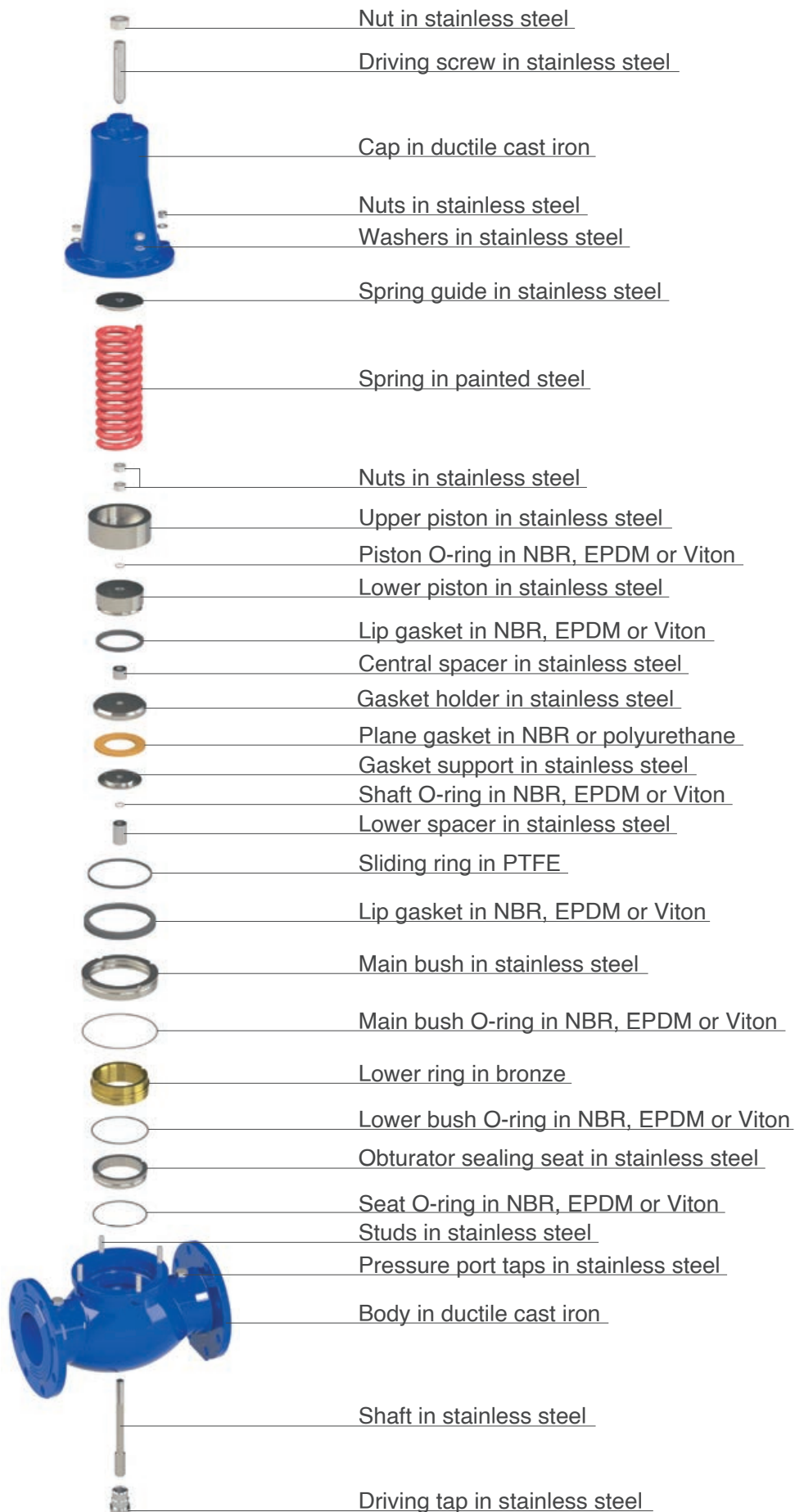

Installation layout

The picture below shows the installation of PF pressure relief/sustaining valve WR/AM as an effective protection device for pressure reducing valves stations, in this case obtained by means of PF pressure reducing valve W-VAL HP. On the by-pass a smaller W-VAL HP will guarantee for the proper regulation even during maintenance while combination anti-surge air valves PF Mod. WAVE 3S-AWH allow for the protection against negative pressure and effective removal of air pockets, gathered during start up and working conditions.



Installation layout

The picture below shows the installation layout of PF pressure relief/sustaining valve WR/AM as an effective surge prevention system and protection device for water pumping stations, located in derivation from the main line just downstream of pumps. Thanks to the direct acting pressure balanced piston technology the WR/AM will guarantee a faster response compared to control valve ensuring the absence of unwanted surge in case of rapid pump start up and, more important, transients consequent to power failure.



Pressure relief/sustaining valve in stainless steel - Mod. WR/AM TH

The PF direct acting spring loaded valve Mod. WR/AM TH automatically maintains and sustains a minimum pre-set upstream pressure, discharging any excess downstream, regardless of variations in demand and downstream pressure fluctuations. The piston actuated WR/AM TH will operate in derivation from the line, as a protection from unwanted pressure rises and/or on the line as pressure sustaining valve.



Technical features and benefits

- Entirely manufactured in stainless steel machined from a solid bar, without any welding.
- Upstream pressure balanced piston technology.
- Different spring ranges available.
- Mobile block composed of stainless steel internals obtained by CNC to ensure the maximum accuracy and sliding precision, this is to ensure the best reliability and to avoid friction.
- Excellent resistance to cavitation and aggressive environments thanks to the design and the use of a wide selection of gaskets made in special materials.

Applications

- Water distribution systems.
- Fire fighting systems.
- Irrigation systems.
- Buildings and civil installations whenever stainless steel is required or advised for project requirements.
- Demineralized water and bottling plants.
- Industry and cooling systems.

Operating principle

The operating principle of WR/AM TH is based on a piston sliding into the body through a drip tight lip gasket. The latter and the diaphragm on the upper part form a watertight chamber, also known as the compensation chamber.



Valve normally closed

Without any incoming pressure the WR/AM TH is a normally closed valve, as shown in the picture, where the obturator is kept pushed down to the seat by the force of the spring.

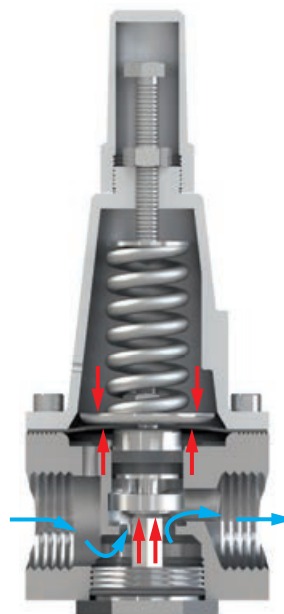

Valve fully open

Should the upstream pressure rise above the set point of the valve, obtained by the compression of the spring, the WR/AM TH will open completely allowing the full passage through the seat.



Valve modulating

Should the upstream pressure fluctuate around the valve's set point the obturator, thanks to the difference in force between the spring pushing downwards and the incoming pressure underneath and through the compensation chamber pushing upwards, will move throttling the flow through the seat in order to maintain the minimum required value.

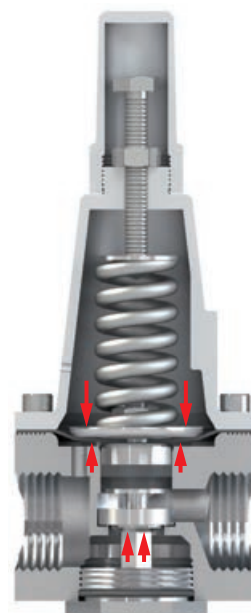

Valve fully closed (static conditions)

Should the water supply and upstream pressure begin to drop, the WR/AM TH will react immediately to maintain and stabilize the required value even in static conditions, thanks to the pressure balanced technology and compensation chamber.

Technical data

Thread (inches)	1"
Kv (m ³ /h)/bar	4,95

Head loss coefficient

Kv coefficient representing the flow rate which is flowing through the valve fully open producing a head loss of 1 bar.

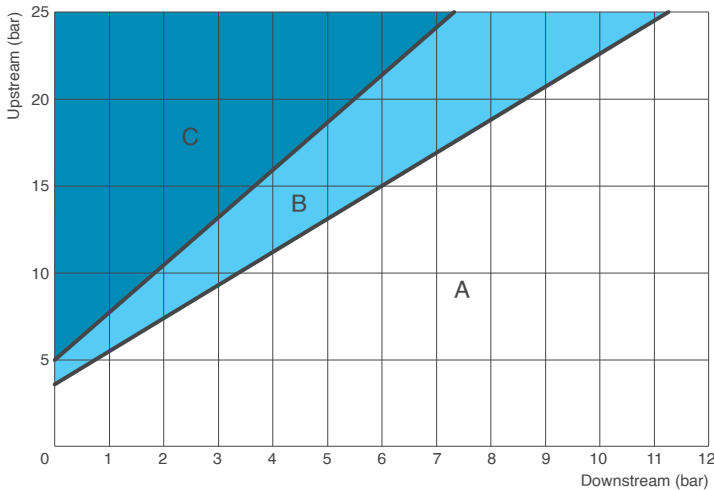

Cavitation chart

- A: Recommended working conditions;
- B: Incipient cavitation;
- C: Damage cavitation.

Ensure that the working point, obtained connecting upstream (y axis) and downstream (x axis) pressure conditions, falls on the A zone with the smallest valve to meet the required flow, contact PF for further assistance. The chart is to be used for valves modulating with an opening percentage between 35-40% at standard water temperature and elevation below 300 m. For continuous pressure sustaining the maximum allowed Δp shall not exceed 17 bar. The pressure relief function will tolerate higher pressure differential values.

Working conditions

Treated water with a maximum temperature of 70°C.
Higher temperatures on request.
Upstream pressure (inlet): maximum 25 bar.

Standard

Certified and tested in compliance with EN 1074/5.
Threaded BSP connections.
Variations on the thread available on request.

Recommended flow rate - pressure sustaining

Thread (inches)	1"
Flow rate min. (l/s)	0,03
Flow rate max. (l/s)	0,8

Recommended flow rate - pressure relief

Thread (inches)	1"
Flow rate max. (l/s)	1,4

Springs pressure ranges

Thread (inches)	1"
Spring pressure (bar)	0,7-7
	1,5-15

Higher values available on request.

Weights and dimensions

Thread (B) inches	1"
A (mm)	81
C (mm)	205
Weight (Kg)	2,7

Values are approximate, consult PF service for more details.

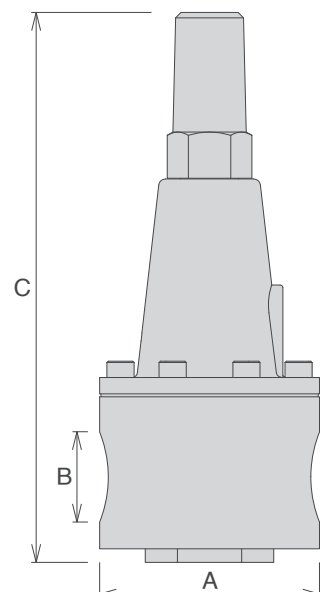

Technical details

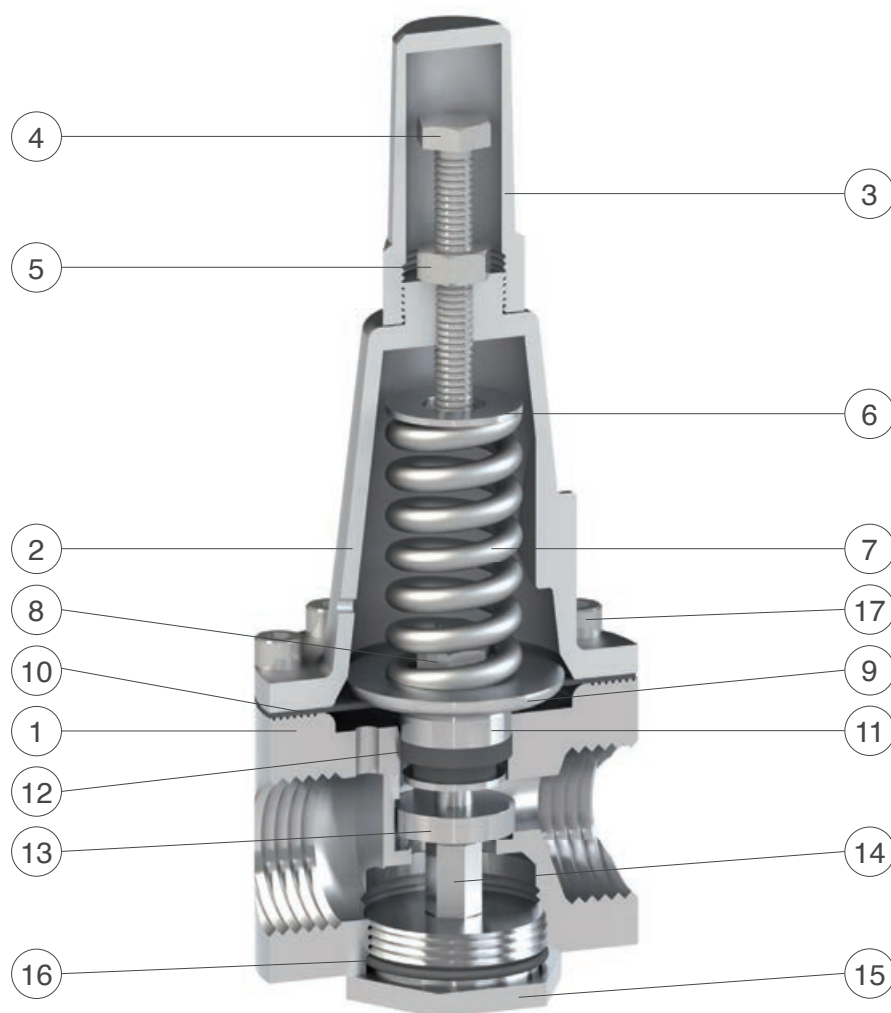

N.	Component	Standard material	Optional
1	Body	stainless steel AISI 303	stainless steel AISI 316
2	Cover	nickel-plated bronze	stainless steel
3	Hood	stainless steel AISI 303	stainless steel AISI 316
4	Regulating screw	stainless steel AISI 304	stainless steel AISI 316
5	Nut	stainless steel AISI 304	stainless steel AISI 316
6	Spring guide	stainless steel AISI 303	stainless steel AISI 316
7	Spring	painted steel 52SiCrNi5	
8	Self-locking nut	stainless steel AISI 304	stainless steel AISI 316
9	Upper flat	stainless steel AISI 303	stainless steel AISI 316
10	Diaphragm	EPDM-Nylon	
11	Piston	stainless steel AISI 303	stainless steel AISI 316
12	Lip gasket	NBR	EPDM/Viton
13	Obturator with plane gasket	stainless steel AISI 303 and polyurethane	stainless steel AISI 316
14	Blocking nut	stainless steel AISI 303	stainless steel AISI 316
15	Driving tap	stainless steel AISI 303	stainless steel AISI 316
16	O-ring	NBR	EPDM/Viton
17	Screws	stainless steel AISI 304	stainless steel AISI 316

The list of materials and components is subject to changes without notice.

Fast acting anti-water hammer valve Mod. H-PVS

The PF fast acting, surge prevention, pressure relief valve Mod. H-PVS has been designed to avoid the devastating effects of water hammers in pipeline networks. The purpose is actually to prevent pressure from rising above a pre-set value, thanks to its capability of discharging the excessive volume of water directly into the atmosphere.



Technical features and benefits

- Solid and compact design suitable for treated and raw water and to reduce blow-back.
- Negligible inertia of the internal mobile parts ensuring the absence of friction and long lasting performances.
- Perfect water tightness and excellent resistance to cavitation and harsh working conditions due to the floating obturator technology and to the use of special gaskets and high resistant stainless steel grades.
- Fast and accurate response without any hysteresis effect thanks to high frequency annealed springs.
- Reduced overpressure thanks to a wide selection of spring and ranges in pressure.
- Water vertical discharge deflector.

Applications

- Downstream of pumping stations to cushion sudden overpressure as a result of pump start up and power failure (in case of one or more pumps in parallel).
- Downstream and upstream of main transmission lines, or pipe segments, not able to endure critical conditions such as sudden and unexpected rise in pressure, and to guarantee reliable system protection.
- Downstream of a pressure reducing valve as a safety device.
- Upstream of modulating and sectioning devices with rapid response time, likely to generate unwanted surges.
- In general, whenever and wherever pipe bursts are expected.

Operating principle

The valve must be pre-set at first, simply acting on the spring, to open whenever the pressure rises above a certain value considered critical for the system.

The particular shape and construction, along with the perfect centring of the mobile block, will protect the upper part against water spurts coming from H-PVS operation cycles. The valve is supplied with a pressure gauge and drainage ball valve, in order to facilitate the pressure measurement and setting procedure directly on the field.

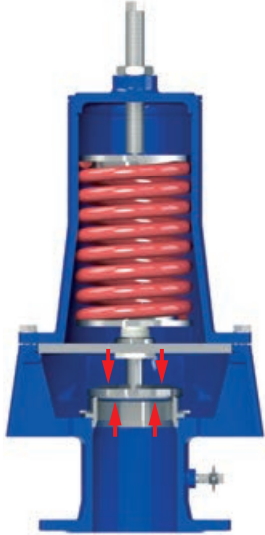

Valve closed

Should the pressure remain below the valve's set point the H-PVS will be perfectly closed, thanks to the compression of the spring pushing the obturator down to the seat.

Valve open

Should the pressure rise above the valve's set point the obturator will rise, discharging to the atmosphere the excessive fluid volume necessary to avoid the upsurge.



Fast acting performance

The graph below shows the response of the fast acting pressure relief valve H-PVS under transient conditions. In this particular case we have actual pressure recordings from a pump station subject to frequent power failures. Without any protection the system was subject to a decrease in pressure at first followed by a dangerous surge, depicted on the plot in light blue, while with the installation of the H-PVS fast acting relief valve the increase in pressure was contained with no further damage to the pipeline. The frequency of the recording with the valve shows the absence of delay with regards to the same without, proving the adequate response time. On the picture on the right particular of the valve during discharge, the vertical deflector on the lower body ensures the absence of spurts around it.

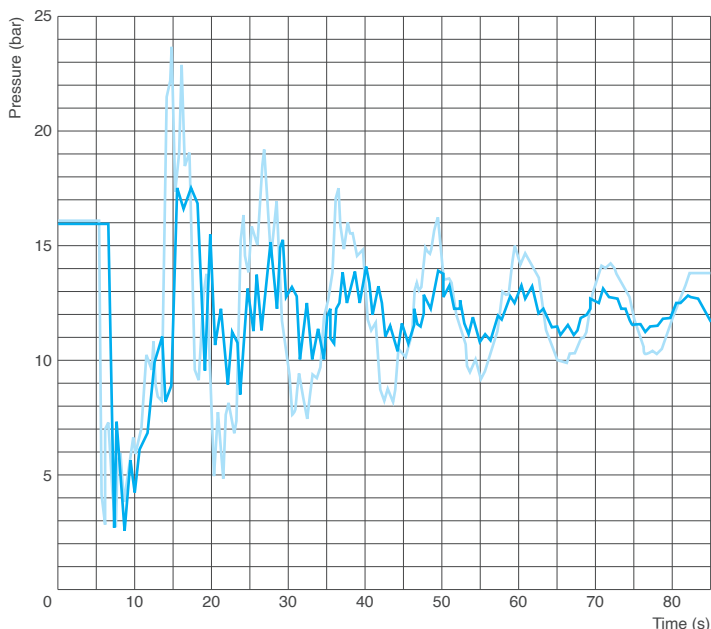

Technical data

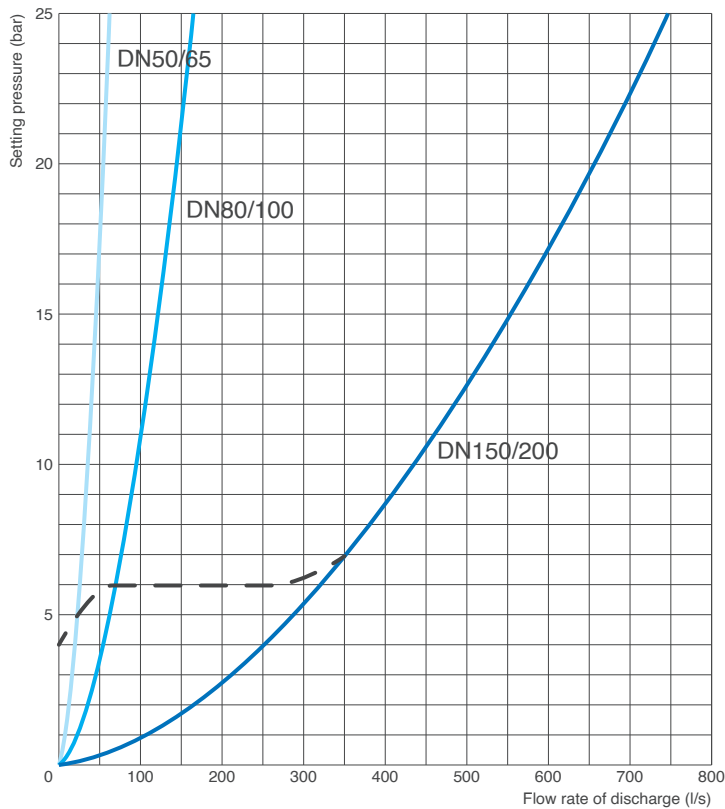

DN mm	PN bar	Setting bar	Flow rate max. l/s	Overpressure bar
50/65	10	1-8	36	0,8
50/65	16	8-16	47	1,5
50/65	25	16-25	62	2,2
80/100	10	1-8	95	1
80/100	16	8-16	126	2
80/100	25	16-25	165	2,5
150/200	10	1-8	435	2
150/200	16	8-16	577	2,5
150/200	25	16-25	745	3,5

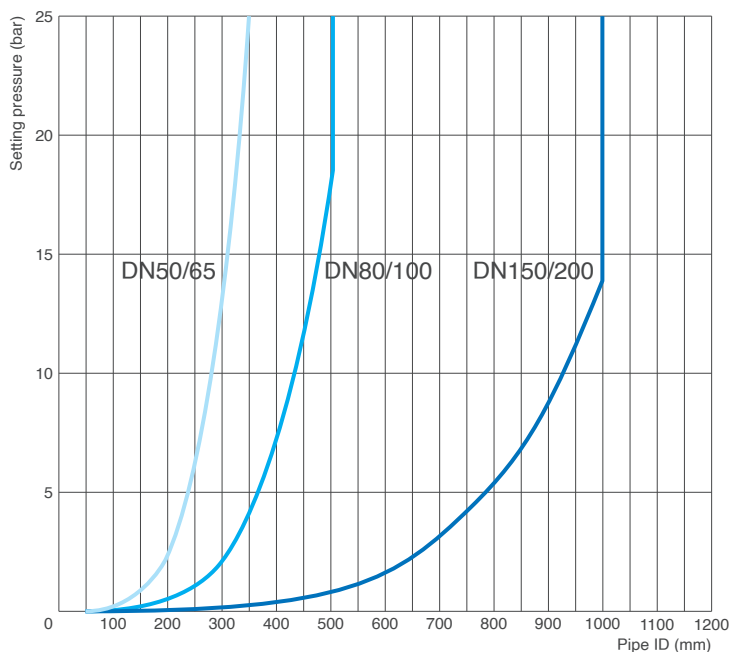

Valve discharge sizing chart

The plot on the left shows the valve's capacity during discharge with full opening of the obturator. For the adequate protection of the pipeline we strongly advise to size the valve in order to cope with at least 35% of the nominal flow, while a more comprehensive and detailed surge analysis is available from PF on request.

The overpressure is another important aspect to be considered during sizing, with an indication of the behaviour of the valve under transient events depicted below by a tolerance between static and dynamic expressed by the overpressure value.

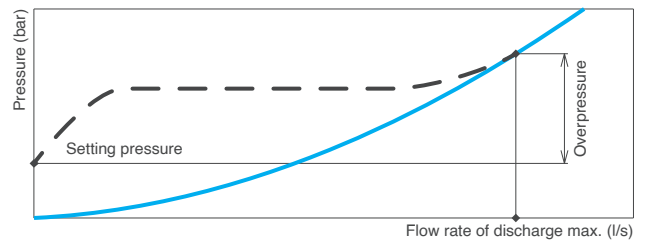

Discharge rate and overpressure

The table shows the discharge flow rates of the valve with different pressure set-points, and the corresponding overpressure. The H-PVS are supplied with three springs to cover the following pressure ranges:

- 1-8 bar,
- 8-16 bar,
- 16-25 bar.

Higher values are available on request for the DN 50/65 and the DN 80/100.

Preliminary sizing chart

The function of the fast acting relief valve PF Mod. H-PVS is to protect piping systems, pumps, vessels and other equipment from excess in pressure and potential damages.

For the sizing overpressure values, blow-down effects and installation criteria must be taken into account, purely as an indication and for a preliminary assessment use the following chart showing the recommended valve's DN versus pressure setting and pipe ID. Ensure that the operating conditions fall on the left of the curve of the chosen valve.

Installation

The fast acting pressure relief valve H-PVS must be installed in a vertical position with isolation device to ensure the proper maintenance and, if required, setting on the field. The installation chamber, if within a closed environment of underground, shall be provided with a proper drainage system to avoid the risk of flooding during the valve's discharge. Shouldn't a valve be enough for the purpose we recommend the installation of two units in parallel with a manifold to be sized on request, and/or two or even more valves in series located on separated outlets.



Working conditions

Treated and raw water with a maximum temperature of 70°C.
 Maximum pressure 25 bar. Spring setting ranges: 1-8 bar, 8-16 bar, 16-25 bar.
 Higher pressure values on request.

Standard

Certified and tested in compliance with EN 1074/5. Flanges according to EN 1092/2.
 Epoxy painting blue RAL 5005 applied through fluidized bed technology.
 Changes on flanges and painting on request.

Weights and dimensions

DN mm	A mm	B mm	C mm	D mm	Seat DN mm	Weight Kg
50/65	185	185	417	40	40	14
80/100	235	242	540	50	62	28
150	300	404	720	220	137	75
200	360	404	720	220	137	79

Values are approximate, consult PF service for more details.

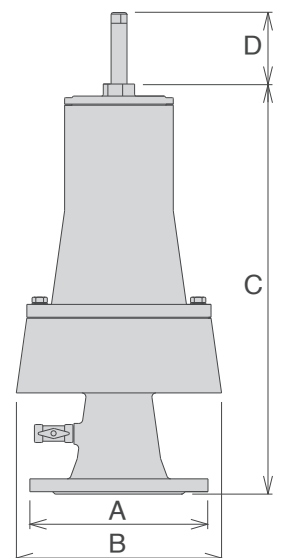

Example of common applications

Pumping station. The following pictures shows some common applications for the fast acting pressure relief valve H-PVS. The H-PVS is installed downstream of pumps check valves, as close to the drain as possible. The installation in vertical position, away from the main pipe, avoid potential spurts generated during discharge. Particular of the installation with an anti surge combination air valve PF WAVE/WAVE LITE 3S-AWH for the protection against negative pressure conditions.

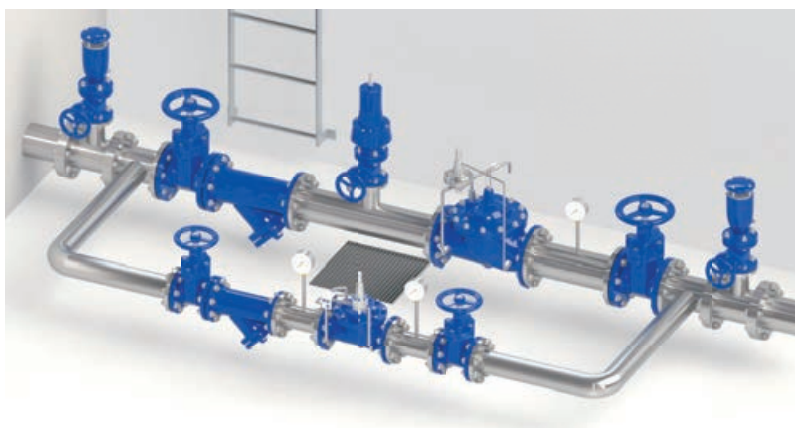
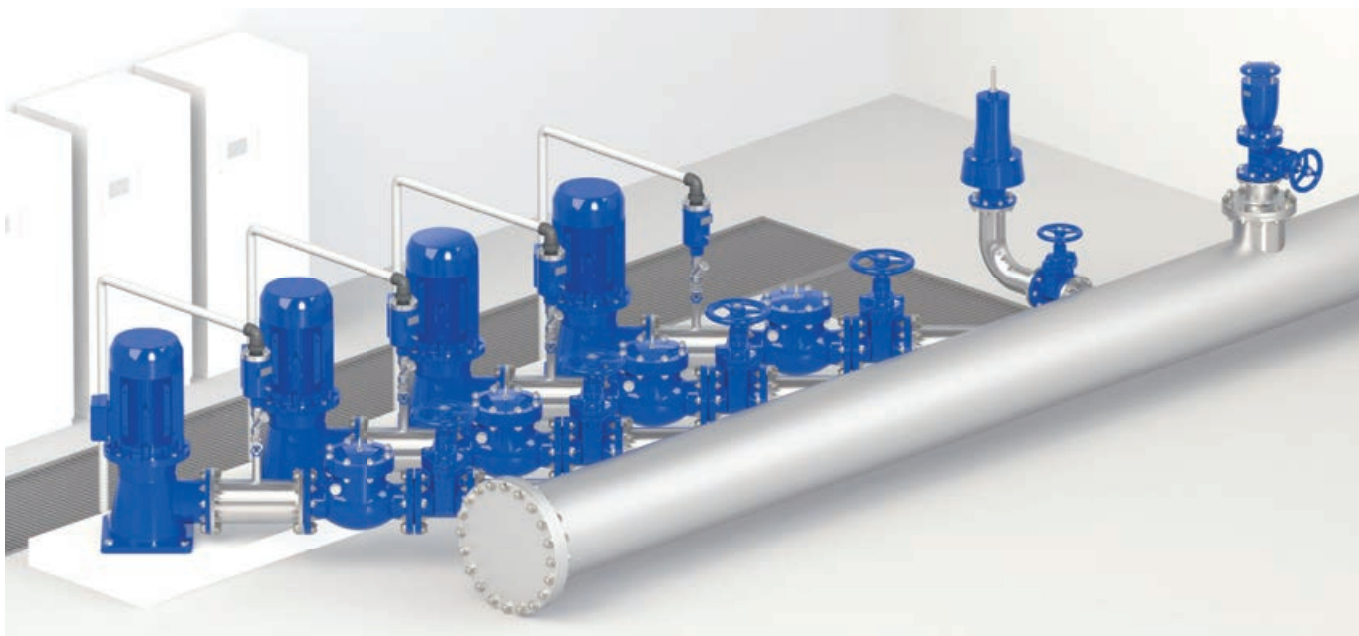

Burst valves and opening/closing devices

The H-PVS is installed upstream of fast closing devices, such as burst flow automatic control valve Mod H-VAL 380/480 model, due to the potential upsurge created by the flow interruption. Air valves PF combination anti-surge WAVE or WAVE LITE 3S-AWH or CSF are always recommended upstream and downstream of the installation.



Level control

In case of level control, especially with valve controlling the minimum and maximum, the risk of overpressure and danger to the pipeline has to be considered. We strongly recommend, should that be the case, to install a H-PVS upstream of the regulating device or to contact PF for different solutions.

Technical details

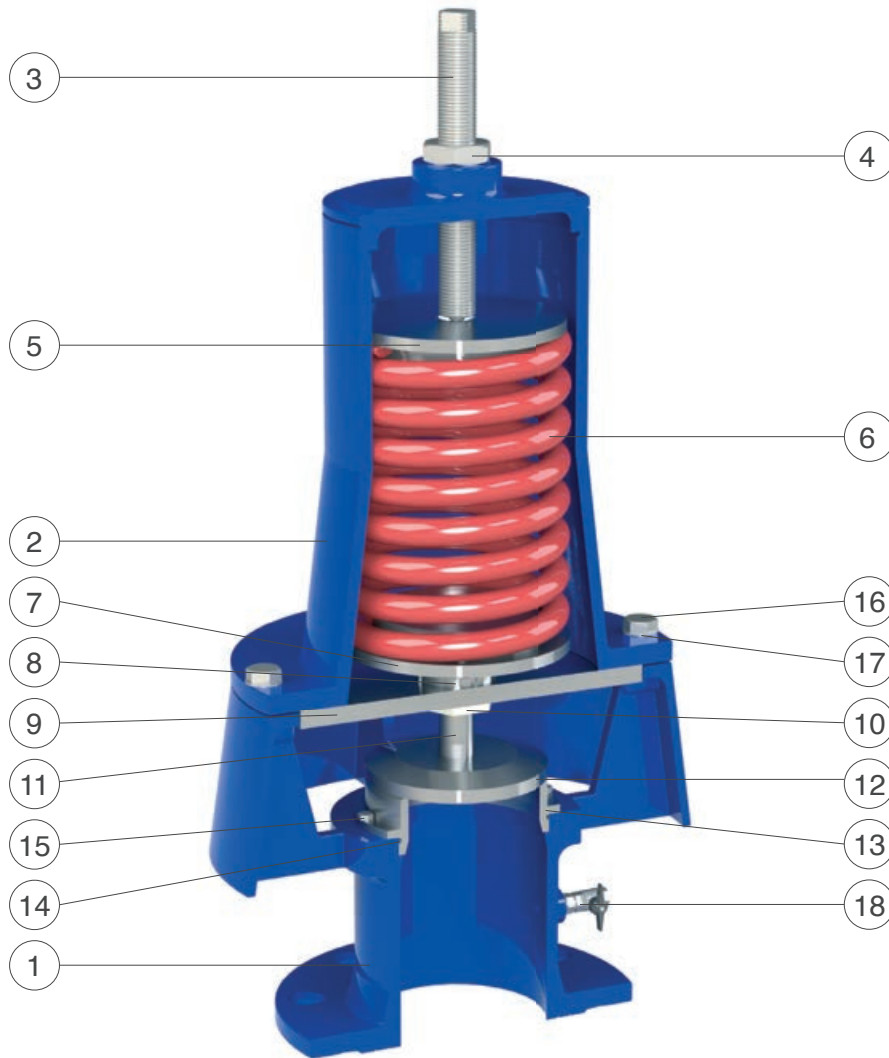

N.	Component	Standard material	Optional
1	Body	ductile cast iron GJS 450-10	
2	Cap	ductile cast iron GJS 450-10 and painted steel	
3	Driving screw	stainless steel AISI 304	stainless steel AISI 316
4	Nut	stainless steel AISI 304	stainless steel AISI 316
5	Spring support	stainless steel AISI 303 (304 for DN 150-200)	stainless steel AISI 316
6	Spring	spring painted steel 52SiCrNi5	
7	Spring housing	stainless steel AISI 303 (304 for DN 150-200)	stainless steel AISI 316
8	Ring	stainless steel AISI 304	stainless steel AISI 316
9	Separation plate	s.s. AISI 304 (painted steel for DN 150-200)	stainless steel AISI 316
10	Driving sleeve	Delrin (s. s. AISI 304 for DN 150-200)	
11	Shaft	stainless steel AISI 304	stainless steel AISI 316
12	Obturator	stainless steel AISI 303 (304 for DN 150-200)	stainless steel AISI 316
13	Sealing seat	stainless steel AISI 304 (303 for DN 50/65)	stainless steel AISI 316
14	O-ring	NBR	EPDM/Viton
15	Screws	stainless steel AISI 304	stainless steel AISI 316
16	Screws	stainless steel AISI 304	stainless steel AISI 316
17	Washers	stainless steel AISI 304	stainless steel AISI 316
18	Ball valve 1/4"	nickel-plated brass	stainless steel AISI 316

Fast acting anti-water hammer valve with flanged outlet - Mod. H-PVS 90F

The PF fast acting, surge prevention, pressure relief valve Mod. H-PVS 90F has been designed to avoid the devastating effects of water hammers in pipeline networks. The purpose is actually to prevent pressure from rising above a pre-set value, thanks to its capability of discharging the excessive volume of water through its flanged outlet.



Technical features and benefits

- Solid and compact design suitable for treated and raw water and to reduce blow-back.
- Negligible inertia of the internal mobile parts ensuring the absence of friction and long lasting performances.
- Perfect water tightness and excellent resistance to cavitation and harsh working conditions due to the floating obturator technology and to the use of special gaskets and high resistant stainless steel grades.
- Fast and accurate response without any hysteresis effect thanks to high frequency annealed springs.
- Wide selection of spring and ranges in pressure.
- Flanged outlet which allows to direct the water outflow through a discharge pipe.
- The valve is supplied with a pressure gauge and drainage ball valve, in order to facilitate the pressure measurement and setting procedure directly on the field.

Applications

- Downstream of pumping stations to cushion sudden overpressure as a result of pump start up and power failure (in case of one or more pumps in parallel).
- Downstream and upstream of main transmission lines, or pipe segments, not able to endure critical conditions such as sudden and unexpected rise in pressure, and to guarantee reliable system protection.
- Downstream of a pressure reducing valve as a safety device.
- Upstream of modulating and sectioning devices with rapid response time, likely to generate unwanted surges.
- In general, whenever unwanted upsurges may occur.

Operating principle

The valve must be pre-set at first, simply acting on the spring, to open whenever the pressure rises above a certain value considered critical for the system.



Valve normally closed

Without any incoming pressure the H-PVS 90F is a normally closed valve, as shown in the picture, where the obturator is kept pushed down to the seat by the force of the spring.

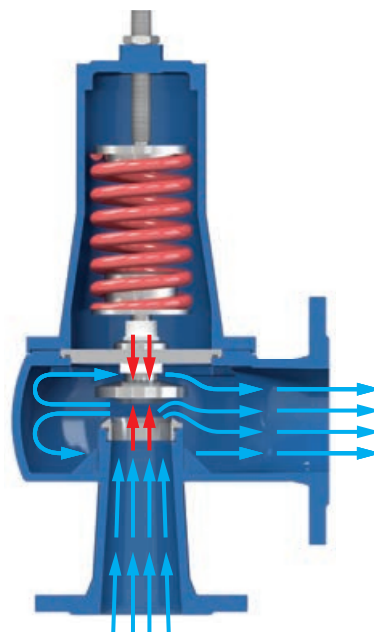

Valve fully open

Should the upstream pressure rise above the set point of the valve, obtained by the compression of the spring, the H-PVS 90F will open completely allowing the full passage through the seat.

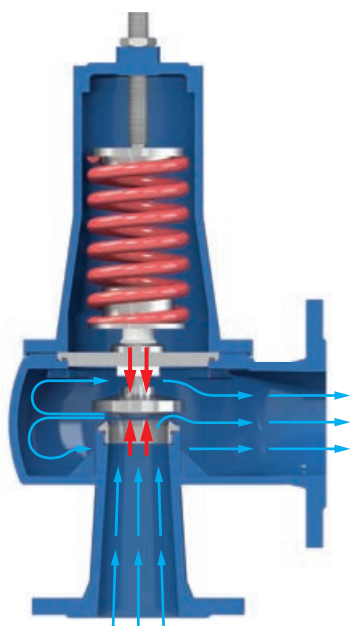

Valve modulating

Should the upstream pressure fluctuate around the valve's set point the obturator, thanks to the difference in force between the spring pushing downwards and the incoming pressure underneath pushing upwards, will move throttling the flow through the seat in order to maintain the minimum required pressure value.

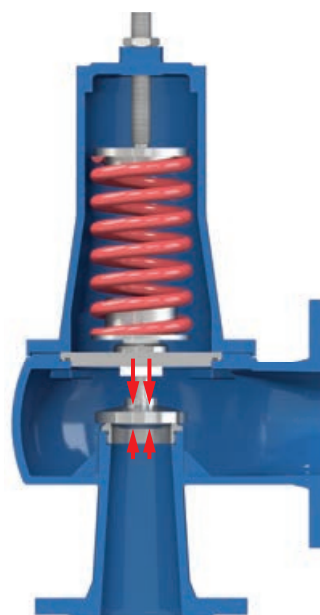

Valve fully closed (static conditions)

Should the water supply and upstream pressure begin to drop, the H-PVS 90F will react immediately to maintain and stabilize the required value even in static conditions, thanks to the pressure balanced mobile block.

Technical data

DN (mm)	50/65	80	100	150
Kv (m ³ /h)	50	101	158	273
Stroke (mm)	17	21	23,5	35

Head loss coefficient

Kv coefficient representing the flow rate which is flowing through the valve fully open, and producing a head loss of 1 bar.

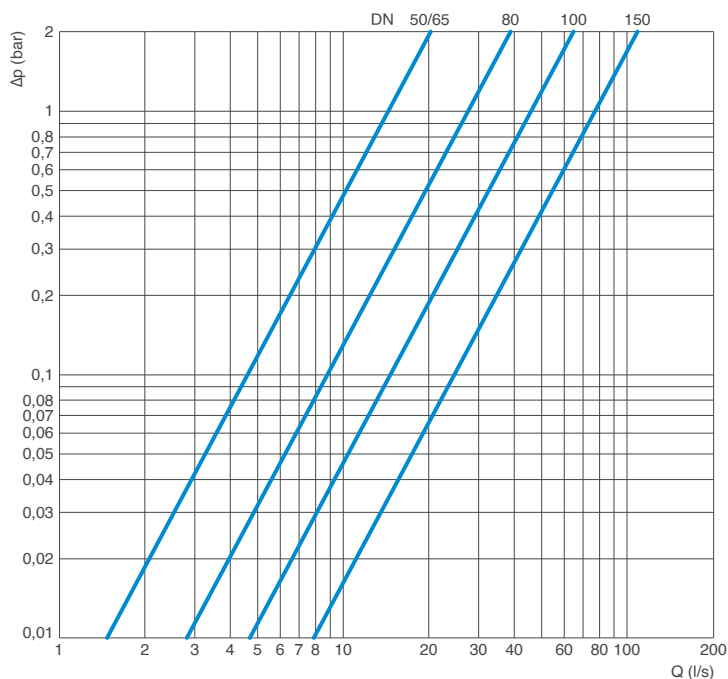

Head loss chart

The chart indicates the head loss of the valves fully open versus flow rate in l/s.

DN mm	PN bar	Setting bar	Overpressure bar
50/65	10	1-8	0,8
50/65	16	8-16	1,5
50/65	25	16-25	2,2
80	10	1-8	1
80	16	8-16	2
80	25	16-25	2,5
100	10	1-8	1
100	16	8-16	2
100	25	16-25	2,5
150	10	1-8	2
150	16	8-16	2,5
150	25	16-25	3,5

Overpressure

The table shows the overpressure of the valve with different pressure set-points. The H-PVS 90F are supplied with three springs to cover the following pressure ranges:

- 1-8 bar,
- 8-16 bar,
- 16-25 bar.

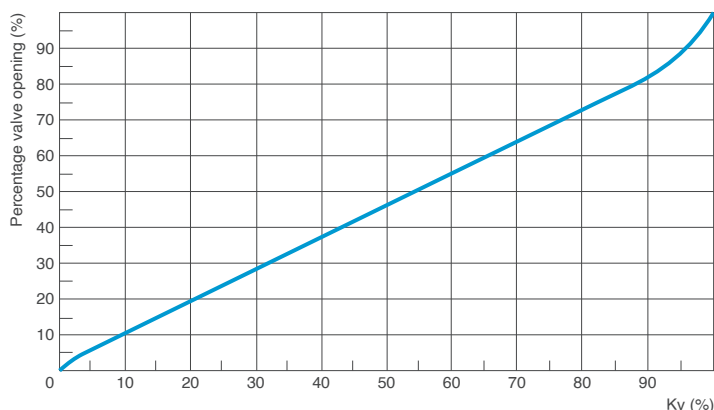

Kv to valve opening chart

The chart aside shows the opening percentage of the valves versus the Kv.

Technical data

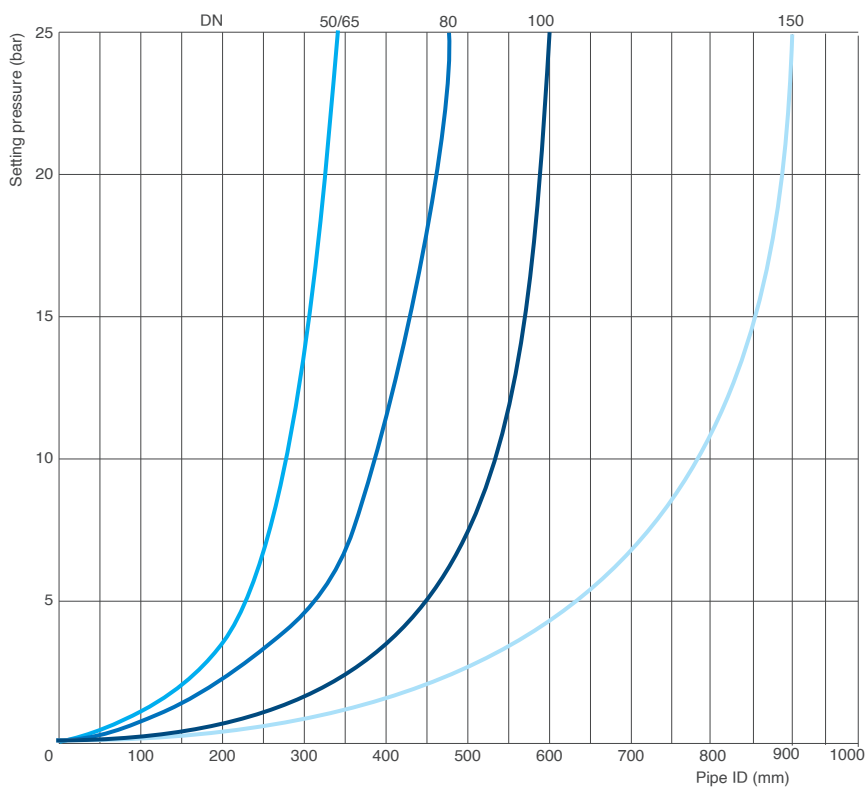

Preliminary sizing chart

The function of the fast acting relief valve PF Mod. H-PVS 90F is to protect piping systems, pumps, vessels and other equipment from excess in pressure and potential damages.

For the sizing overpressure values, blow-down effects and installation criteria must be taken into account, purely as an indication and for a preliminary assessment use the following chart showing the recommended valve's DN versus pressure setting and pipe ID. Ensure that the operating conditions fall on the left of the curve of the chosen valve.

DN (mm)	50/65	80	100	150
Flow rate max. (l/s)	12,5	26	41	72

Advised flow rates

The table shows the recommended maximum flow rates for the different sizes.

Working conditions

Treated and row water.
Maximum temperature of 70°C.
Maximum pressure 25 bar.
Spring setting ranges: 1-8 bar, 8-16 bar, 16-25 bar.

Standard

Certified and tested in compliance with EN 1074/5.
Flanges according to EN 1092/2.
Epoxy painting blue RAL 5005 applied through fluidized bed technology. Changes on flanges and painting on request.

Weights and dimensions

Inlet DN mm	A mm	B mm	C mm	D mm	E mm	F mm	G mm	Seat DN mm	Outlet DN mm	Weight Kg
50/65	185	188	418	100	200	130	150	43,5	80	20
80	200	244	542	130	235	184	177	60	100	36
100	235	244	567	130	270	196,5	177	75	125	41
150	300	409	758	165	360	235	335	100	200	111

Values are approximate, consult PF service for more details.

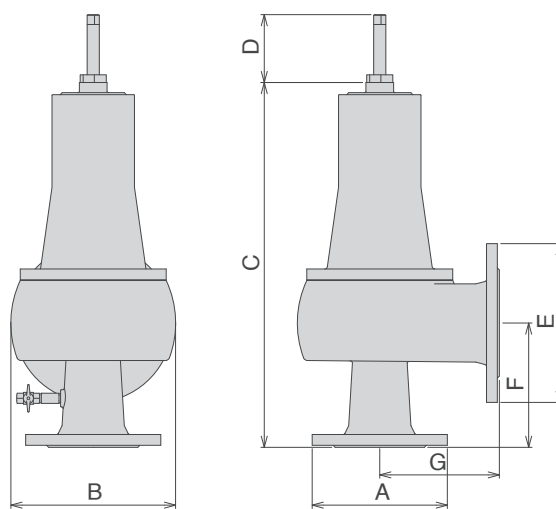

Examples of common applications

Pumping station. The following picture shows a characteristic application of the fast acting pressure relief valve H-PVS 90F, installed downstream of pumps check valves. Particular of the installation with an anti surge combination air valve PF WAVE or WAVE LITE 3S-AWH for the protection against negative pressure conditions.



Pressure reduction valve station. In this second layout H-PVS 90F is installed downstream of a pressure reduction valve station to prevent in any case rise in pressure on the main line. The installation also includes the pressure reducing valve PF H-VAL 310/410, a by-pass for maintenance and anti-surge combination air valves WAVE or WAVE LITE 3S-AWH upstream and downstream.

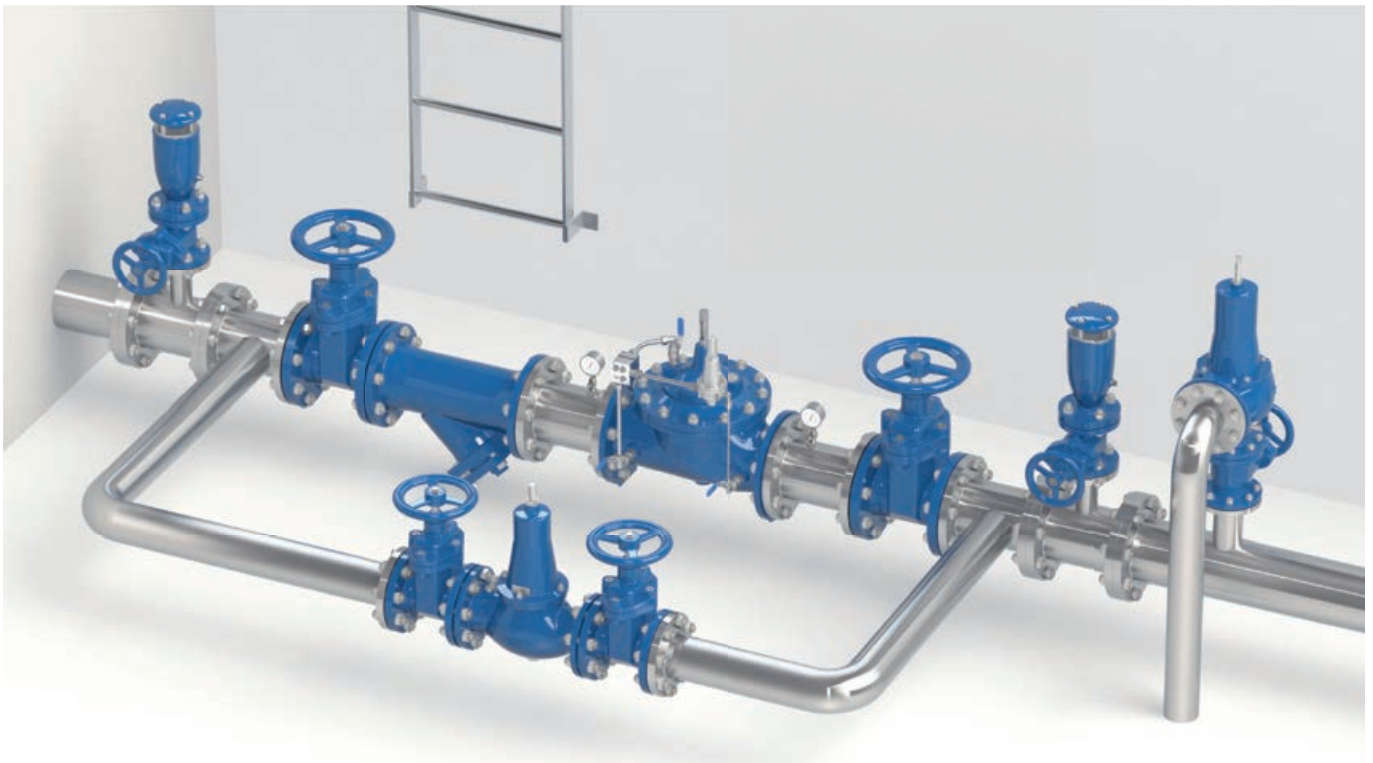

Technical details

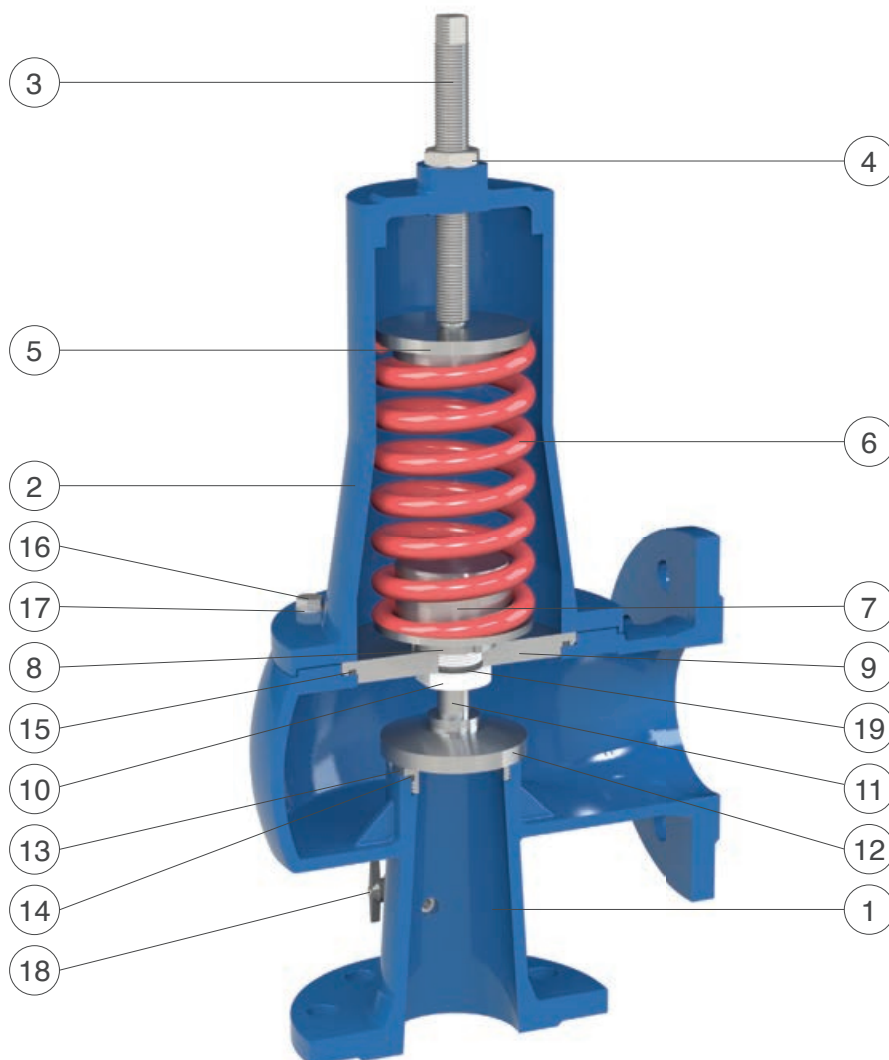

N.	Component	Standard material	Optional
1	Body	ductile cast iron GJS 450-10	
2	Cap	ductile cast iron GJS 450-10 and painted steel	
3	Driving screw	stainless steel AISI 304	stainless steel AISI 316
4	Nut	stainless steel AISI 304	stainless steel AISI 316
5	Spring support	stainless steel AISI 303 (304 for DN 150-200)	stainless steel AISI 316
6	Spring	spring painted steel 52SiCrNi5	
7	Spring housing	stainless steel AISI 303 (304 for DN 150-200)	stainless steel AISI 316
8	Ring	stainless steel AISI 304	stainless steel AISI 316
9	Separation plate	s.s. AISI 304 (painted steel for DN 150-200)	stainless steel AISI 316
10	Driving sleeve with O-ring	Delrin (s. s. AISI 304 for DN 150-200) and NBR	
11	Shaft	stainless steel AISI 304	stainless steel AISI 316
12	Obturator with plane gasket	st. st. AISI 303 (304 for DN 150-200) and polyurethane	stainless steel AISI 316
13	Sealing seat	stainless steel AISI 304 (303 for DN 50/65)	stainless steel AISI 316
14	O-ring	NBR	EPDM/Viton
15	O-ring	NBR	EPDM/Viton
16	Screws	stainless steel AISI 304	stainless steel AISI 316
17	Washers	stainless steel AISI 304	stainless steel AISI 316
18	Ball valve 1/4"	nickel-plated brass	stainless steel AISI 316
19	O-ring	NBR	EPDM/Viton

The list of materials and components is subject to changes without notice.

Fast acting anti-water hammer valve in stainless steel - Mod. H-PVS TH

The PF fast acting, surge prevention, pressure relief valve Mod. H-PVS TH has been designed to prevent pressure from rising above a pre-set value, thanks to its capability of discharging the excessive volume of water directly through its conveying threaded outlet.



Technical features and benefits

- Solid and compact design.
- Entirely made in stainless steel.
- Negligible inertia of the internal mobile parts ensuring the absence of friction and long lasting performances.
- Perfect water tightness and excellent resistance to cavitation and harsh working conditions.
- Fast and accurate response without any hysteresis effect thanks to high frequency annealed springs.
- The threaded outlet allows the connection to external pipes to convey spurts generating by operation cycles.

Applications

- Water distribution systems.
- Fire fighting systems.
- Irrigation systems.
- Buildings and civil installations whenever stainless steel is required or advised for project requirements.
- Demineralized water and bottling plants.
- Industry and cooling systems.

Operating principle

The operating principle of H-PVS TH is based on a piston sliding into the body through a drip tight O-ring gasket.

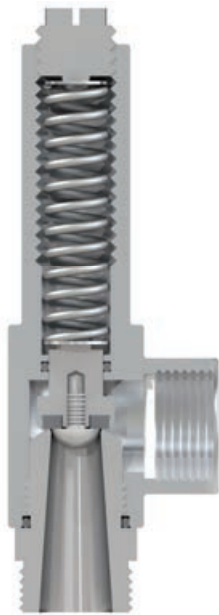

Valve normally closed

Without any incoming pressure the H-PVS TH is a normally closed valve, as shown in the picture, where the obturator is kept pushed down to the seat by the force of the spring.

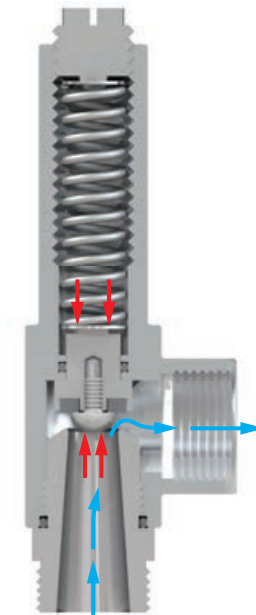

Valve fully open

Should the upstream pressure rise above the set point of the valve, obtained by the compression of the spring, the H-PVS TH will open completely allowing the full passage through the seat.

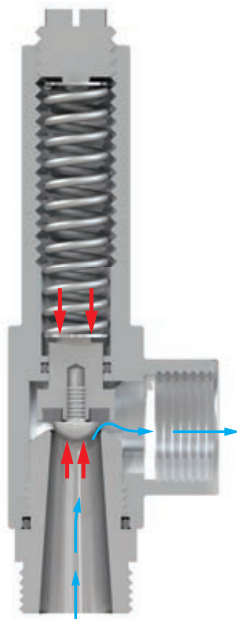

Valve modulating

Should the upstream pressure fluctuate around the valve's set point the obturator, thanks to the difference in force between the spring pushing downwards and the incoming pressure underneath pushing upwards, will move throttling the flow through the seat in order to maintain the minimum required value.

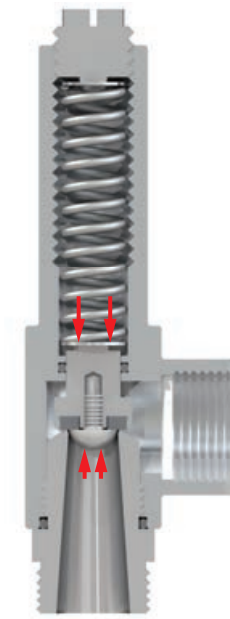

Valve fully closed (static conditions)

Should the water H-PVS TH will react immediately to maintain and stabilize the required value even in static conditions, thanks to the pressure balanced technology and compensation chamber.

Technical data

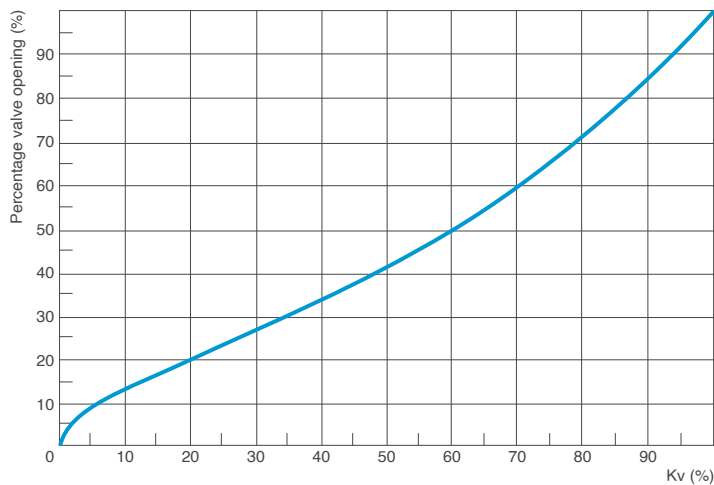

Kv to valve opening chart

The chart aside shows the opening percentage of the valve versus the Kv.

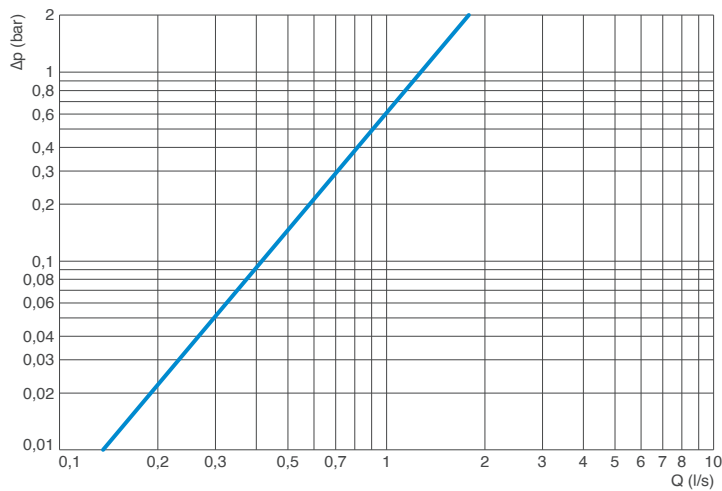

Head loss chart

The chart indicates the head loss of the valve fully open versus flow rate in l/s.

Working conditions

Treated water with a maximum temperature of 70°C.

Higher temperatures on request.

Upstream pressure (inlet): maximum 25 bar.

Technical data

Kv equal to 6,3 m³/h.

Recommended flow rate: 5 m³/h.

Spring setting ranges: 1-8 bar, 2-16 bar, 4-24 bar.

Weight 2,3 Kg.

Standard

Certified and tested in compliance with EN 1074/5.

Threaded BSP connections.

Variations on the inlet thread available on request.

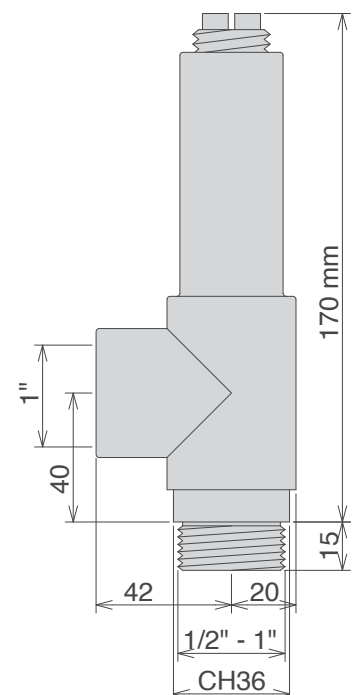

Technical details

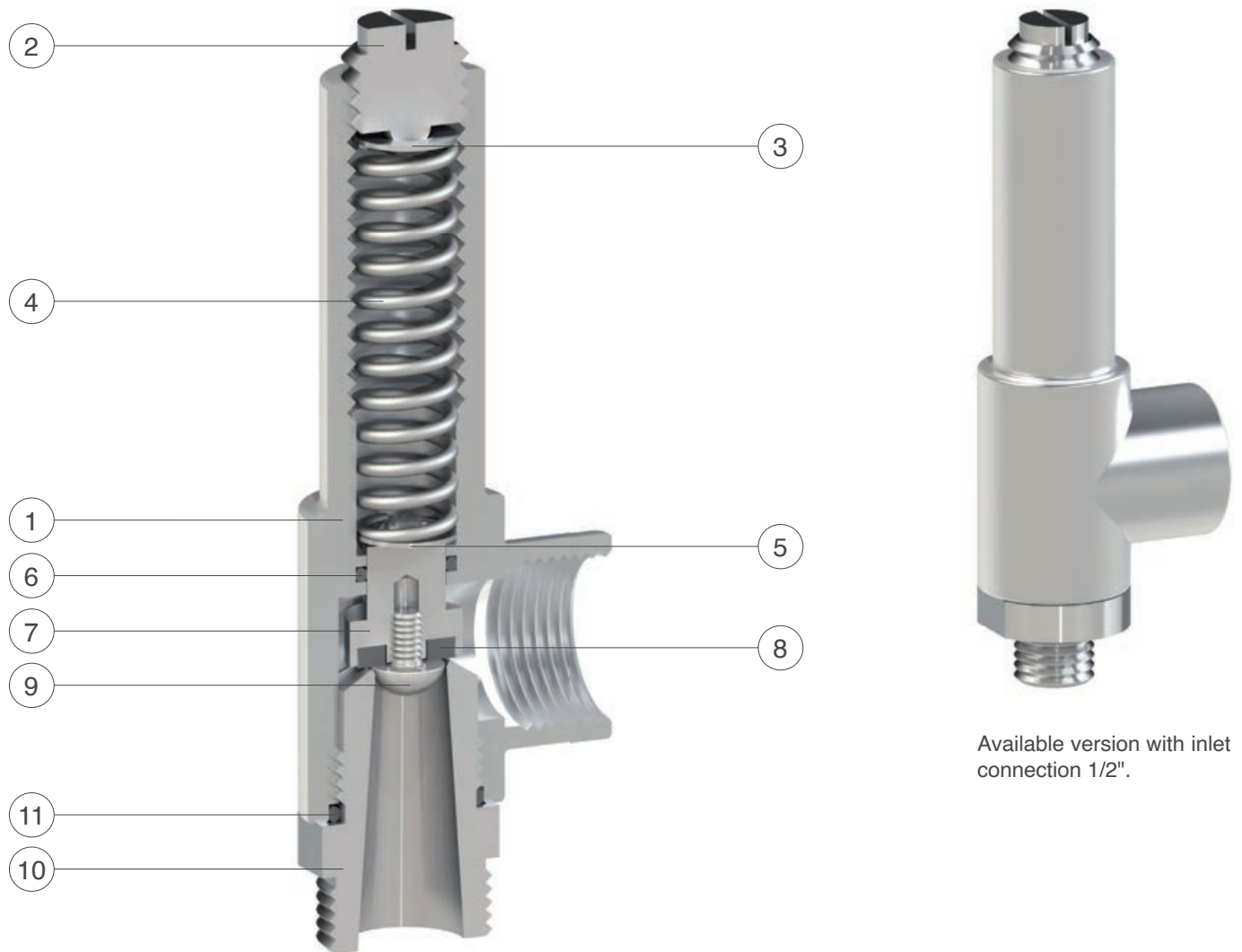

Available version with inlet connection 1/2".

N.	Component	Standard material	Optional
1	Body	stainless steel AISI 316	
2	Driving screw	stainless steel AISI 304	stainless steel AISI 316
3	Spring upper support	stainless steel AISI 304	
4	Spring	stainless steel AISI 302	
5	O-ring	NBR	EPDM/Viton
6	Spring lower support	stainless steel AISI 304	
7	Obturator	stainless steel AISI 304	stainless steel AISI 316
8	Plane gasket	polyurethane	
9	Screw	stainless steel AISI 304	
10	Sealing seat	stainless steel AISI 304	stainless steel AISI 316
11	O-ring	NBR	EPDM/Viton