

## Automatic control valves H-VAL 300 and 400 series

The PF H-VAL range consist of a globe pattern hydraulically operated automatic control valves, namely 400 for the full bore and 300 for the reduced bore series, entirely produced in ductile cast iron with internal components in stainless steel.

Diaphragm actuated PN 25 class, the valve is designed to perform a tremendous range of applications including pressure reduction, relief, sustain, flow control, level control and many more. Each function is obtained simply by changing the circuitry and pilots, that can be combined together.

All information herewith contained referring to operating principle, case studies and installation guidelines, are applicable to the H-VAL 300 and 400 series unless otherwise stated.



**H-VAL 300 series**



**H-FLUX 400 series**

### Technical features and benefits

- Body in ductile cast iron, PN 25 bar rated, globe pattern design in compliance with EN 1074 standards and available from DN 50 mm up to DN 600 mm.
- Designed to reduced head loss and minimize turbulence under a wide flow range.
- Double chambered actuator as an option.
- Stainless steel seat and mobile block assembly entirely removable from the valve.
- Silent operation and absence of vibrations, suitable for buildings and urban applications.
- Technology to reduce the risk of diaphragm failure, the latter manufactured with nylon reinforced fabric.
- Different versions of the modulating assembly, more in details the seat and the gasket holder, to provide excellent resistance to cavitation, low flow stability and obstacle free design.
- In-line serviceable from the top with having to remove the valve from the pipe.
- High quality materials and reliability for long lasting performances with internals all made in stainless steel, obturator and wedge in ductile cast iron for large diameters.

### Applications

- Main transmission lines and water distribution networks.
- Industrial plants.
- Cooling system.
- High-rise buildings.

## Technical features

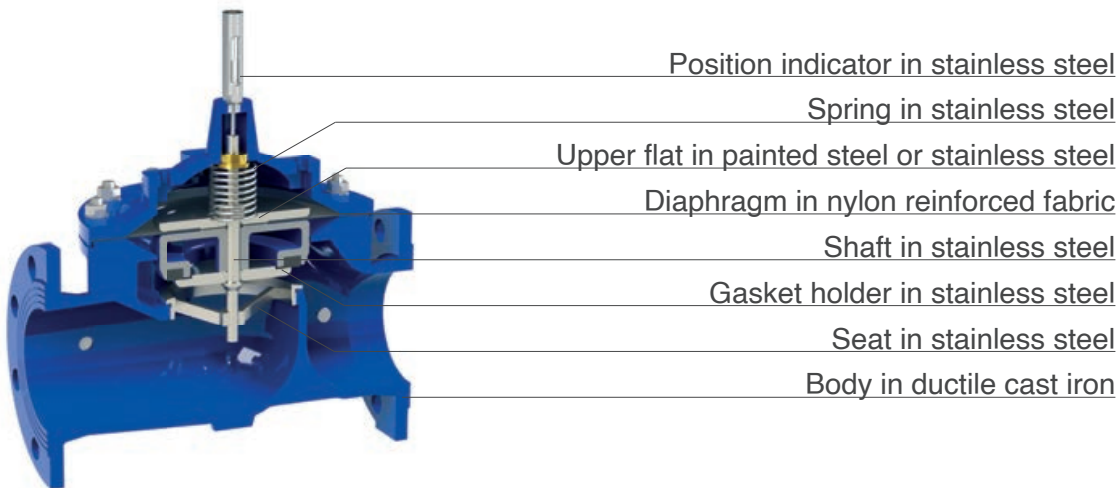

The mobile block includes the obturator, upper flat, diaphragm, shaft and gasket holder, the latter engineered with different versions to guarantee the maximum accuracy and best performances in accordance to the results of the sizing and to the design requirements.



### Standard version of gasket holder and sealing seat

On the standard version the shaft is guided in two points, through the cap and the seat, moving frictionless during modulation. The gasket holder (1a) is machined with a fillet whose radius reduces the risk of hunting at small opening percentage.

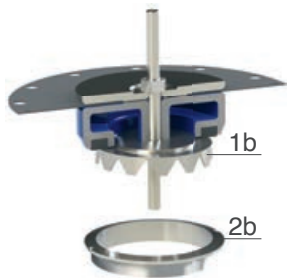

### LF version for low flow stability

The LF includes a gasket holder (1b) with progressive opening allows for stability also in presence of extreme low flow values. Once the opening percentage has increased above the LF system operating range the valve will open completely, ensuring the minimum energy dissipation thanks to unobstructed flow pattern.

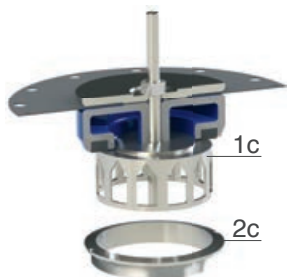

### AC version for low flow stability and cavitation prevention

The anti-cavitation trim AC mobile block includes a gasket holder (1c) designed to increase the allowable pressure ratio and resistance to cavitation, improving at the same time the valve's stability to guarantee the maximum accuracy also in case of no flow.



### CP anti-cavitation version

The CP system includes two cages (1d, 2d) for double energy dissipation between inlet and outlet, whose holes can be customized according to the project in hand and required performances, this is to avoid damages to the valve without a drastic reduction of the valve's Kv.

## Operating principle on-off mode

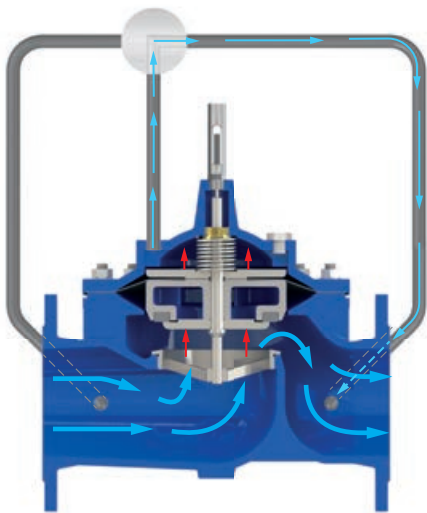

### Valve opening

If the pressure inside the control chamber is put in communication with the atmosphere or some other lower pressure zone, the upstream pressure will act on the obturator, pushing it upwards allowing the complete opening of the valve.

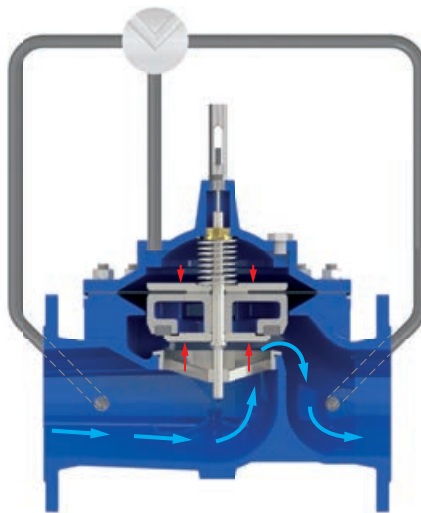

### Valve isolated from the line

Should the control chamber be isolated from the line pressure and the rest of the circuitry the valve will remain in the same position, therefore producing the head loss corresponding to such opening percentage.

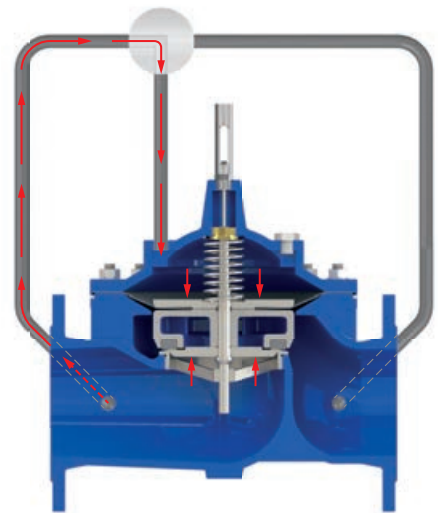

### Valve closing

If the control chamber is put in communication with the upstream pressure, thanks to the difference in area between the upper flat with diaphragm, larger than the obturator underneath, the valve will close completely.

## Operating principle modulating mode

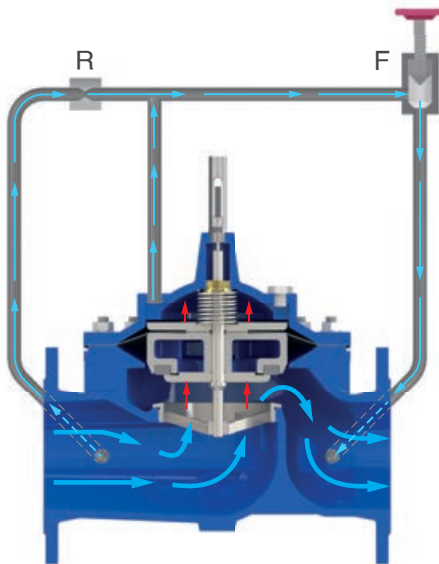

### Valve opening

When the main valve is required to modulate a restriction (R) is needed between the upstream line pressure and the control chamber, in addition to a regulator (F) on the circuit. Should the latter open completely pressure inside the control chamber will be put in communication with downstream, allowing for the full opening of the main valve.

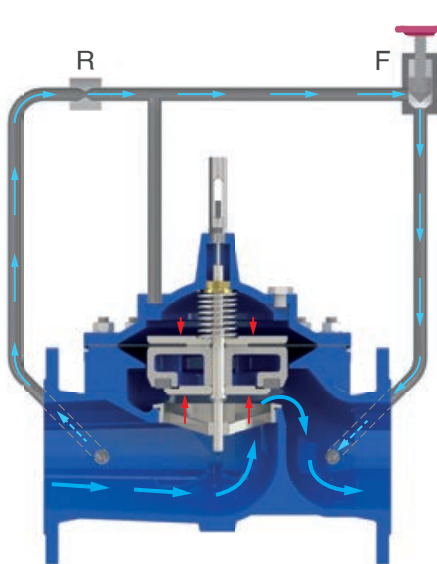

### Valve modulating

If the flow regulator (F) is throttled pressure will build up between it and the control chamber, causing the valve to modulate accordingly to an intermediate position. This is obtained thanks to the pressure difference created by the restriction (R) and to the difference in section between the upper flat acting on the diaphragm and the obturator.

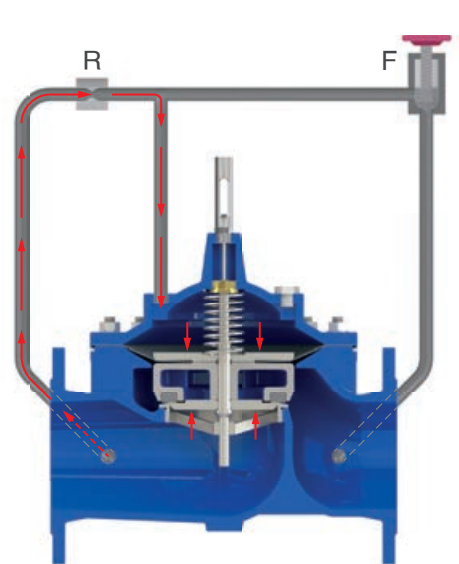

### Valve closing

Should the flow regulator (F) be completely closed, the upstream line pressure is all diverted to the main control chamber. The mobile block is moved by the force exerted on the upper diaphragm flat pushing the obturator down onto the seat, interrupting the flow through the main valve.

## GR.I.F.O. 3/8" PN 25 flow control device

The PF exclusive unit flow control device with built-in filter GR.I.F.O. (patent pending) has been designed to enhance flow stability and accuracy on PF hydraulic control valves H-VAL & H-FLUX series thanks to a combination of adjustable needle valves and check valves. Entirely built in stainless steel, impervious to corrosion, compact and provided with several pressure ports, GR.I.F.O. allows for a tremendous range of regulation reducing at the same time the complexity of the circuit compared to the other solutions available on the market. GR.I.F.O. is composed of the following: a filter, with fine mesh in stainless steel AISI 316, to protect the hydraulic circuitry from possible dirt; three adjustable needle flow stabilizers valves in stainless steel with check valves, needed for the regulation of the main valve's response time, opening and closing speed that remain independent one from the other; filtered and unfiltered pressure ports.

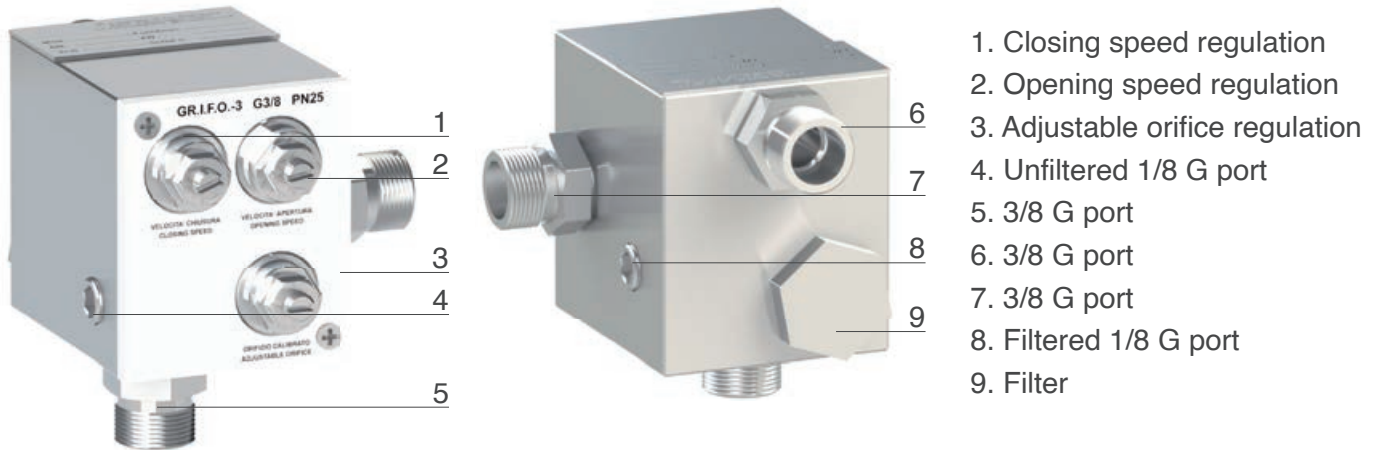

## Operating principle modulating mode - example of pressure reduction

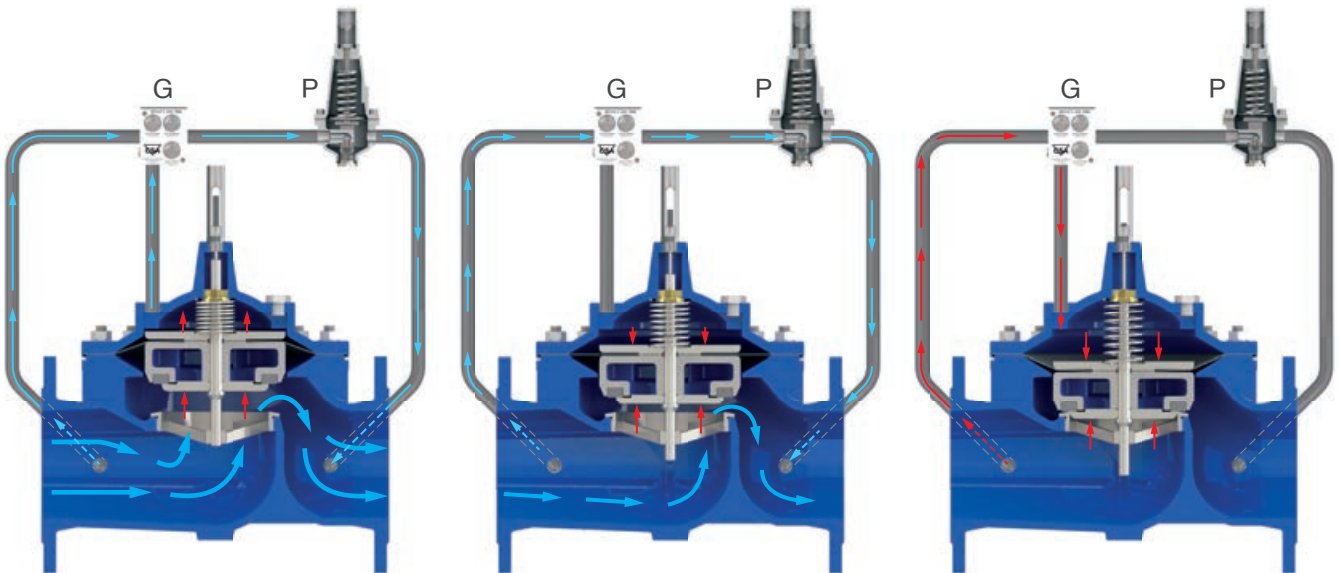

### Valve opening

Should the downstream pressure drop below the pilot's (P) preset and adjustable set point the latter will open, allowing flow and pressure to be relieved out of the main chamber. The mobile block will be lifted increasing the passage between the obturator and the seat trying to re-establish the desired downstream pressure value.

### Valve modulating

As a consequence of gradual change in demands the pilot (P) will keep regulating the flow in and out of the main chamber to compensate for pressure variations. The mobile block will reproduce the pilot's movement, throttling the passage between the seat and obturator to produce the head-loss required for the pressure reduction.

### Valve closing

Should the downstream pressure rise above the pilot's (P) set point the latter will close, allowing pressure to be built up inside the main chamber. The mobile block will be pushed down trying to restore the desired downstream value. In case of static conditions pilot will be fully closed with the valve maintaining the downstream pressure.





## Downstream pressure reducing stabilizing automatic control valve Mod. H-VAL 310/410

The PF model H-VAL 310/410 is a globe pattern hydraulically operated automatic control valve that reduces and stabilizes the downstream pressure to a constant value, regardless of variation in demands and upstream pressure conditions. Normally equipped with visual position indicator and entirely made in ductile cast iron with FBT epoxy coating and stainless steel, the valve is designed to reduce head loss, throttling noise and cavitation damage. The PF pressure reducing stabilizing valve H-VAL 310/410 is extremely versatile and can be used for a wide range of applications.

### Applications

- Downstream of pumps to reduce the pressure on the main supply line.
- Installed in derivation from the main line to stabilize the pressure of secondary line and water users.
- As a protection against rise in pressure of industrial equipment and civil installations.
- On the inlet supply line of storage tanks to stabilize pressure and flow required for the level control.

### Accessories

- Linear position transmitter with 4-20 mA output Mod. PF CSPL.
- On-off position transmitter Mod. PF CSPO.
- Pressure measurement kit.
- Self-flushing and high capacity filter.

### Note to the engineer

- Inlet and outlet pressure, and flow rate are required for the proper sizing.
- PF anti-cavitation low flow stability plugs are recommended to provide an accurate regulation in case of low flow conditions.
- A minimum length of 3 DN downstream of the valve is recommended for the best accuracy.

### Additional features

- H-VAL 310/410-FR downstream pressure reducing with back-flow prevention.
- H-VAL 310/410-H downstream pressure reducing with high sensitivity pilot.
- H-VAL 310/410-G downstream pressure reducing with over pressure guard.

### Working conditions

- Fluid: treated water.
- Minimum operating pressure: 0,7 bar.
- Maximum operating pressure: 25 bar.
- Maximum temperature: 70°C.

### Downstream pressure pilot adjustment range

- Blue spring: 0,7 to 7 bar.
- Red spring: 1,5 to 15 bar.
- Higher values up to 25 bar on request.
- Values lower than 0,7 available with high sensitivity pilots.

## Operating principle

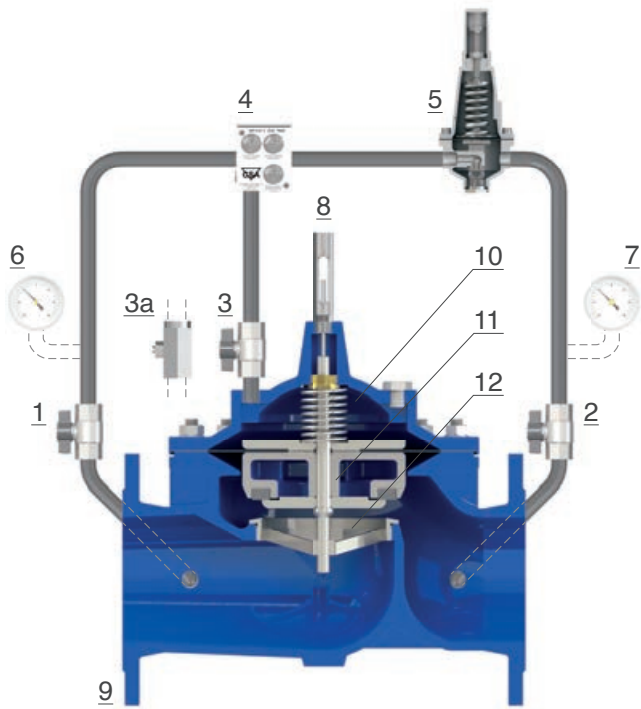

The PF model H-VAL 310/410 is an automatic control valve operated by a 2 ways pilot (5) with pre-set set and adjustable value. Should the downstream pressure rise above the pilot set point the latter will throttle and limit the flow to direct inlet pressure to the main chamber (10), thus pushing down the obturator (11) to generate the head loss required for the valve (9) to reduce and stabilize the downstream pressure to a constant value. Should the downstream pressure fall below the pilot set point the obturator (11) will raise increasing the passage through the seat (12), thus reducing the head loss followed by the rise in pressure. The flow in and out of the main chamber (10) is controlled by the PF unit regulation device with filter GR.I.F.O. (4) provided with three needle valves and flow stabilizers, needed for the valve's response time and accuracy also in case of rapid variation in demand. Thanks to the isolation ball valves (1-2-3) the control circuit and its components can be maintained without interrupting the flow through the main line.

## Installation layout

The H-VAL 310/410 installation lay-out includes sectioning devices (1, 2) and by-pass for maintenance operations, and a filter (3) to prevent dirt from reaching the control valve. The direct acting pressure reducer W-VAL HP (4) is the best choice on the by-pass thanks to its reliability also after long periods of inactivity. Anti-surge combination air valves WAVE 3S-AWH (6, 7) are recommended upstream and downstream as well as a pressure relief valve WR/AM (5) to prevent rise in pressure on the main line.

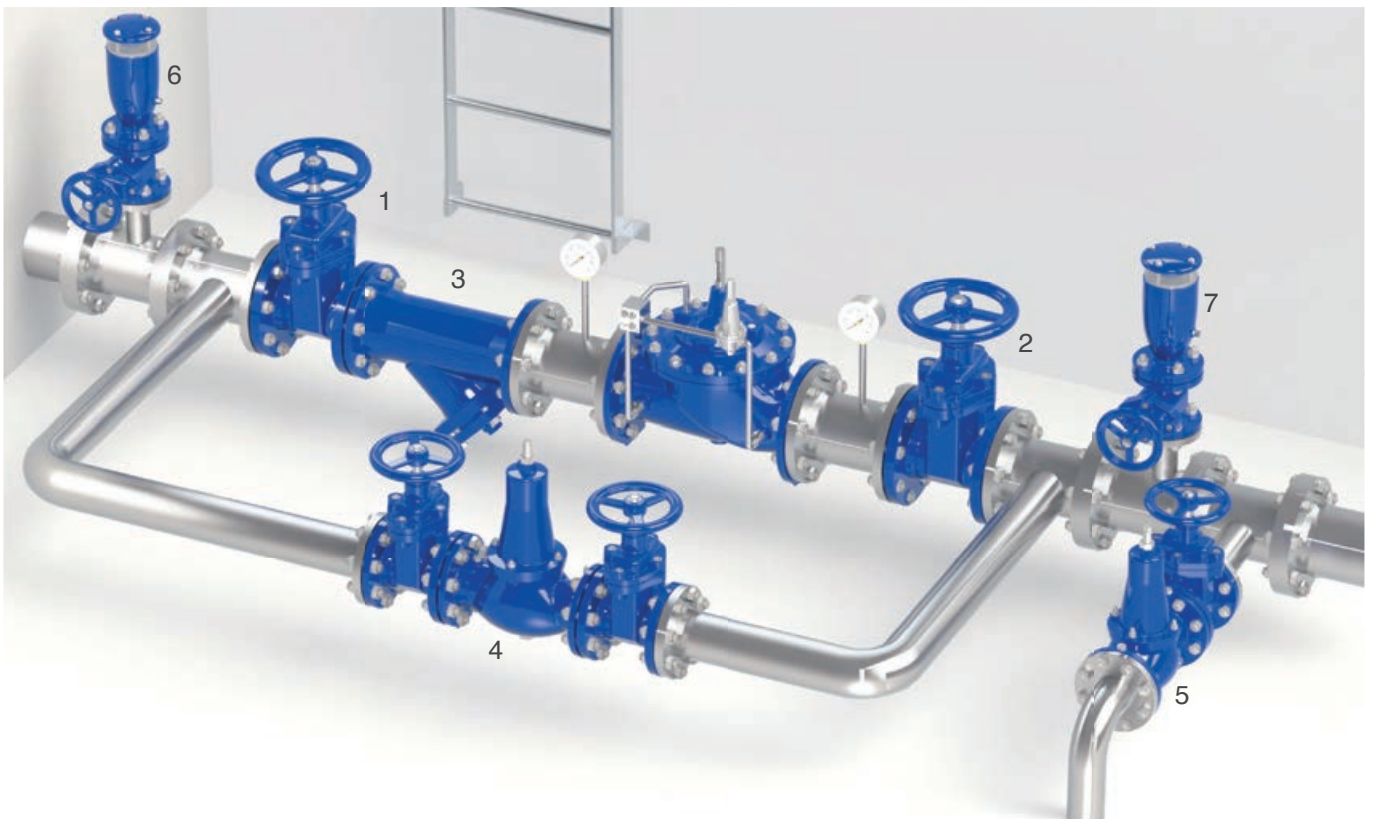



## Downstream pressure reducing stabilizing valve with over pressure guard Mod. H-VAL 310/410-G

The PF model H-VAL 310/410-G is a globe pattern hydraulically operated automatic control valve that reduces and stabilizes the downstream pressure to a constant value, regardless of variation in demands and upstream pressure conditions. Equipped with an additional pilot the valve will make sure to maintain the downstream pressure within the required set point without any unwanted increase and consequent damages to the system. Entirely made in ductile cast iron with FBT epoxy coating and stainless steel, the valve is designed to reduce head loss, throttling noise and cavitation damage.

### Applications

- Downstream of pumps to reduce the pressure on the main supply line.
- Installed in derivation from the main line to stabilize the pressure of secondary line and water users.
- As a protection against rise in pressure of industrial equipment and civil installations.
- On the inlet supply line of storage tanks to stabilize pressure and flow required for the level control.

### Accessories

- Linear position transmitter with 4-20 mA output Mod. PF CSPL.
- On-off position transmitter Mod. PF CSPO.
- Pressure measurement kit.
- Self-flushing and high capacity filter.

### Note to the engineer

- PF anti-cavitation low flow stability plugs are recommended to provide an accurate regulation in case of low flow conditions.
- A minimum length of 3 DN downstream of the valve is recommended for the best accuracy.
- The set point value of the pressure guard pilot should remain within 0,6 bar tolerance on the PRV value.

### Additional features

- H-VAL 310/410-FR downstream pressure reducing with back-flow prevention.
- H-VAL 310/410-H downstream pressure reducing with high sensitivity pilot.

### Working conditions

- Fluid: treated water.
- Minimum operating pressure: 0,7 bar.
- Maximum operating pressure: 25 bar.
- Maximum temperature: 70°C.

### Downstream pressure pilot adjustment range

- Blue spring: 0,7 to 7 bar.
- Red spring: 1,5 to 15 bar.
- Higher values up to 25 bar on request.
- Values lower than 0,7 available with high sensitivity pilots.

### Over pressure guard pilot adjustment range

- Blue spring: 0,7 to 7 bar.
- Red spring: 1,5 to 15 bar.
- Values lower than 0,7 available with high sensitivity pilots.



## Operating principle

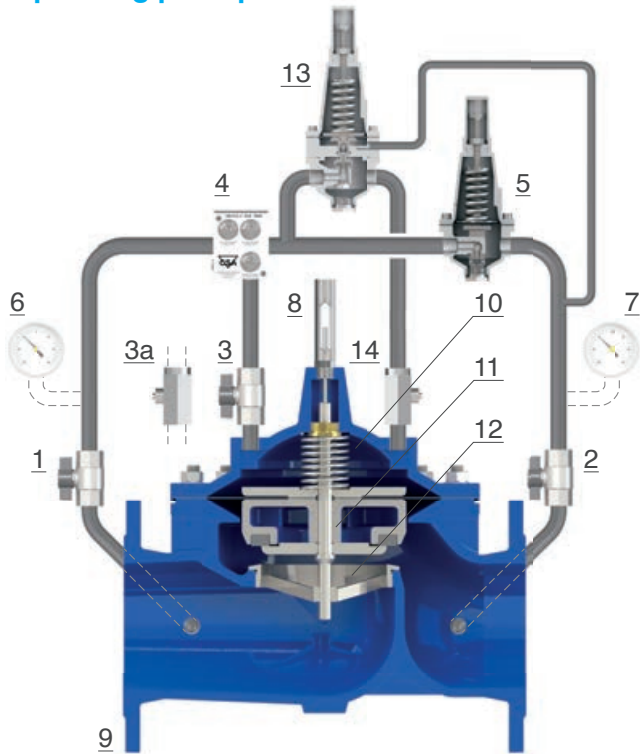

The PF model H-VAL 310/410-G is an automatic control valve operated by a 2 ways pilot (5) for pressure reduction with pre-set set and adjustable value. Should the downstream pressure rise above the pilot set point the latter will throttle and limit the flow to direct inlet pressure to the main chamber (10), thus pushing down the obturator (11) to generate the head loss required for the valve (9) to reduce and stabilize the downstream pressure to a constant value. Should the downstream pressure fall below the pilot set point the obturator (11) will raise increasing the passage through the seat (12), thus reducing the head loss followed by the rise in pressure. The pressure guard pilot (13) senses the variation of the downstream pressure, should the latter rise above the set point the pilot (13) will open diverting the flow towards the control chamber, thus preventing any possible pressure increase above the PRV pilot (5) set point value. Thanks to the isolation ball valves (1-2-3) the control circuit and its components can be maintained without interrupting the flow through the main line.

## Installation layout

The H-VAL 310/410-G installation lay-out includes sectioning devices (1, 2) and by-pass for maintenance operations, and a filter (3) to prevent dirt from reaching the control valve. The pressure reducer W-VAL HP (4) is the best choice on the by-pass thanks to its reliability also after long periods of inactivity. Anti-surge combination air valves WAVE 3S-AWH (6, 7) are recommended upstream and downstream as well as a pressure relief valve WR/AM (5) as a back up to prevent rise in pressure on the main line.

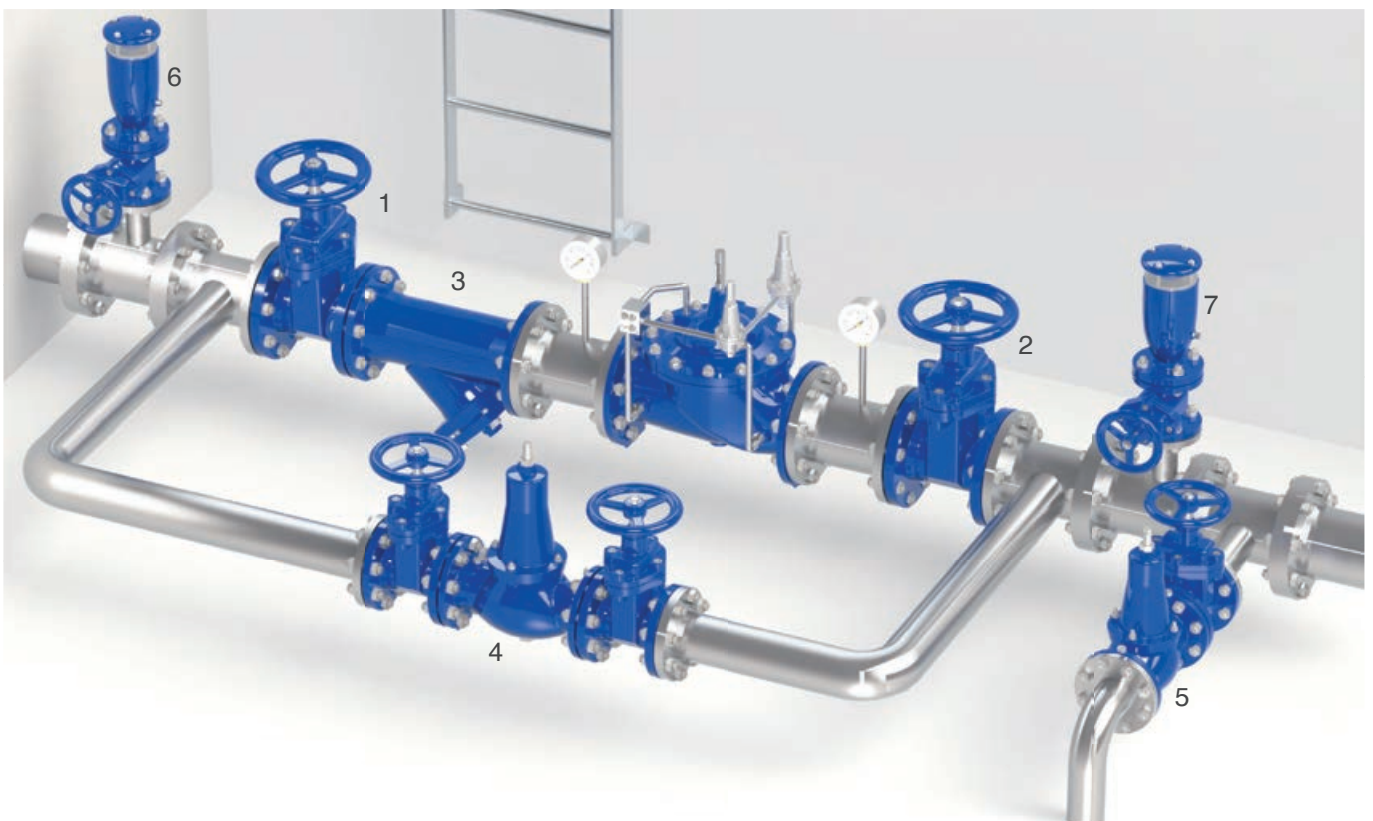





## Downstream pressure reducing valve with two set points Mod. H-VAL 310/410-ND

The PF model H-VAL 310/410-ND is a globe pattern hydraulically operated automatic control valve that reduces and stabilizes the downstream pressure to two pre-set and adjustable values, regardless of variation in demands and upstream pressure conditions, usually corresponding to night and day regulation. Normally equipped with visual position indicator, the valve is designed to reduce head loss, throttling noise and cavitation damage. The PF pressure reducing valve H-VAL 310/410-ND is extremely versatile and mainly used for pressure management and water loss reduction campaigns.

### Applications

- A well-planned pressure management program will extend the life of the system increasing safety and reliability. The automatic control valve PF H-VAL Model. 310/410-ND, thanks to the battery operated programmer, is designed to automatically optimize the downstream pressure regulations in two steps, both adjustable, where the lower values usually corresponds to night time low consumption requirements.

### Accessories

- Linear position transmitter with 4-20 mA output Mod. PF CSPL.
- On-off position transmitter Mod. PF CSPO.
- Pressure measurement kit.
- Self-flushing and high capacity filter.

### Note to the engineer

- PF anti-cavitation low flow stability plugs are recommended to provide an accurate regulation in case of low flow conditions.
- A minimum length of 3 DN downstream of the valve is recommended for the best accuracy.
- The programmer is battery operated with an average lifespan of 13 months if used on a daily basis, different solutions on request.

### Additional features

- H-VAL 310/410-ND-FR night and day downstream pressure reduction with back-flow prevention.
- H-VAL 310/410-ND-H night and day downstream pressure reduction with high sensitivity pilot.
- H-VAL 310/410-ND-5 night and day downstream pressure reduction with solenoid control.

### Working conditions

- Fluid: treated water.
- Minimum operating pressure: 0,7 bar.
- Maximum operating pressure: 16 bar.
- Maximum temperature: 70°C.

### Downstream pressure pilot adjustment range

- Blue spring: 0,7 to 7 bar.
- Red spring: 1,5 to 15 bar.

## Operating principle

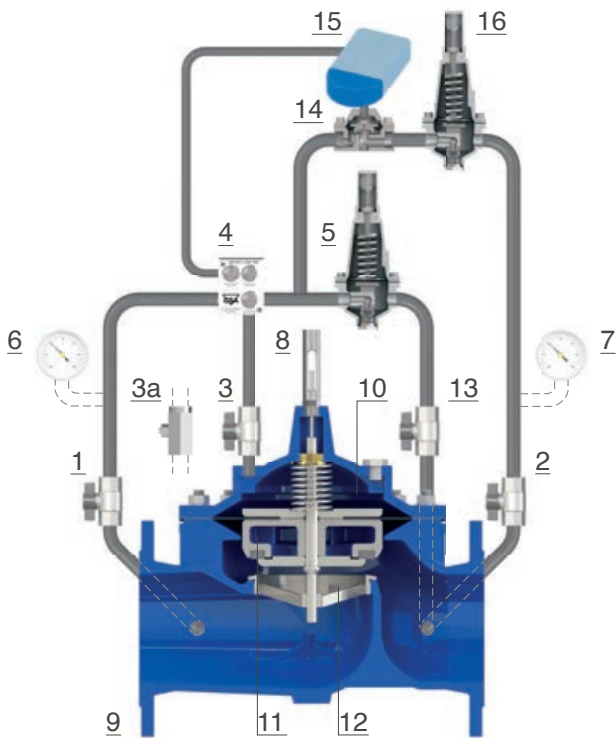

The valve is operated by two 2 ways pilot (5-16), for pressure reduction with pre-set set and adjustable values, activated by a battery operated timer (15) acting on a flow accelerator (14). During night time regulation (low pressure) pilot 5 is working being the two ways valve (14) closed. Should the downstream pressure rise above the pilot (5) set point the latter will throttle and limit the flow to direct inlet pressure to the main chamber (10), to generate the head loss required for the valve (9) to reduce and stabilize the downstream pressure. During the day, or according to the customer's program of the timer (15), the pilot (16) is activated, and being its set point higher than the night time pilot (5) the latter will be forced to the closed position. The flow in and out of the main chamber (10) is controlled by the PF exclusive unit regulation device with filter called GR.I.F.O. (4) and provided with three needle valves and flow stabilizers, needed for the valve's response time and accuracy also in case of rapid variation in demand.

## Installation layout

The recommended H-VAL 310/410-ND installation lay-out includes sectioning devices (1, 2) and by-pass for maintenance operations, and a filter (3) to prevent dirt from reaching the control valve. The direct acting pressure reducer W-VAL HP (4) is the best choice on the by-pass thanks to its reliability also after long periods of inactivity. Anti-surge combination air valves WAVE 3S-AWH (6, 7) are recommended upstream and downstream as well as a pressure relief valve WR/AM (5) to prevent rise in pressure on the line.

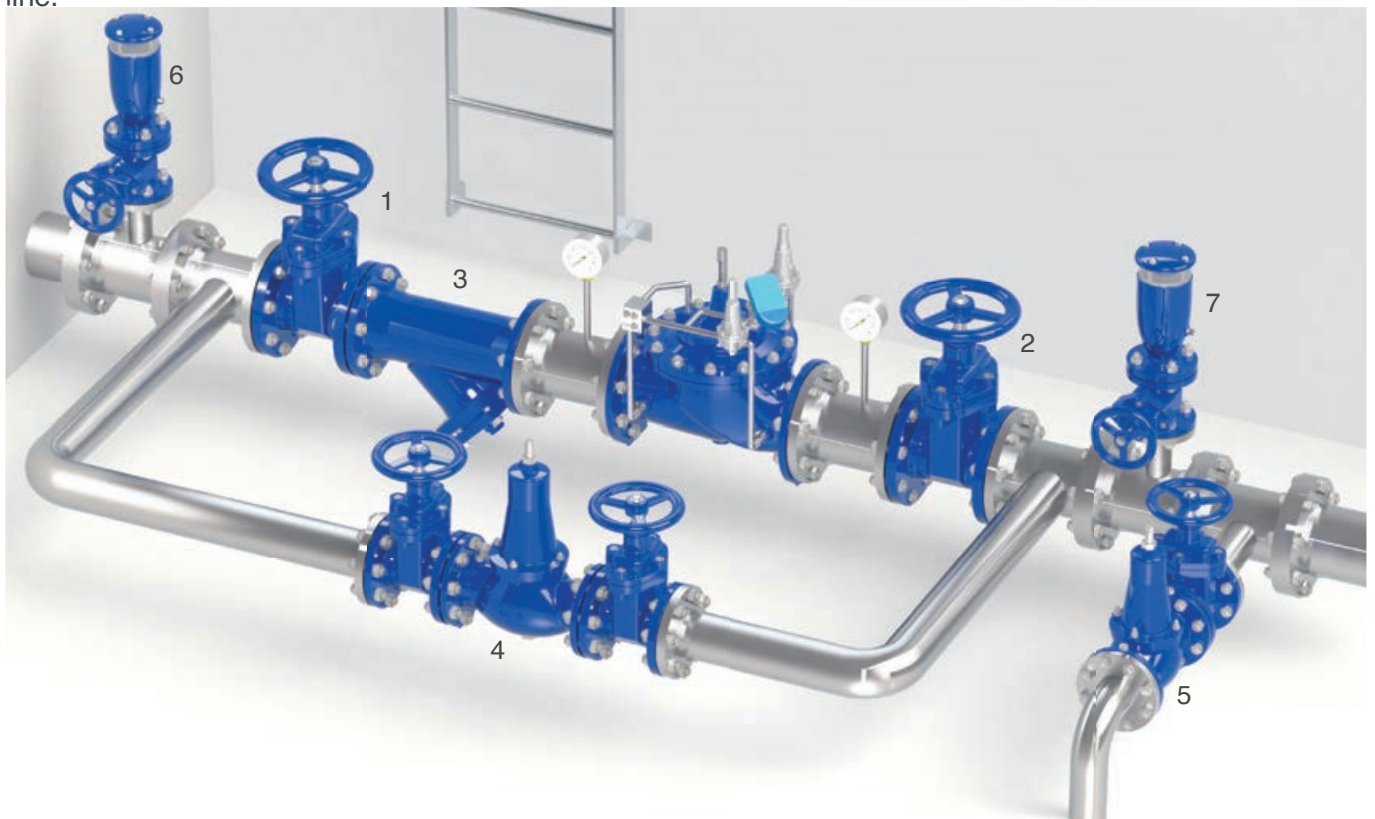



## Pressure management downstream pressure reducing valve **Mod. H-VAL 310/410-ND-H**

The PF model H-VAL 310/410-ND-H is a globe pattern hydraulically operated automatic control valve that reduces and stabilizes the downstream pressure to two pre-set and adjustable values, regardless of variation in demands and upstream pressure conditions, usually corresponding to night and day regulation. Designed to reduce head loss, throttling noise and cavitation damage the valve switches from one pressure to the other according to the flow rate, within an adjustable range.

H-VAL 310/410-ND-H is extremely versatile and mainly used for pressure management and water loss reduction campaigns.

### Applications

- A well-planned pressure management program will extend the life of the system increasing safety and reliability. The automatic control valve PF H-VAL Model 310/410-ND-H, thanks to high sensitivity pilots, is designed to automatically perform the downstream pressure regulations in two values, both adjustable, where the lower values usually corresponds to night time low consumption requirements.

### Accessories

- Linear position transmitter with 4-20 mA output Mod. PF CSPL.
- On-off position transmitter Mod. PF CSPO.
- Pressure measurement kit.
- Self-flushing and high capacity filter.

### Note to the engineer

- PF anti-cavitation low flow stability plugs are recommended in case of low flow.
- A minimum length of 3 DN downstream of the valve is recommended for the best accuracy.
- The flow rate switching point, from one downstream pressure value to the other, is adjusted through an high sensitivity pilot on a scale provided according to the application.

### Additional features

- H-VAL 310/410-ND-H-FR night and day pressure reduction with back-flow prevention.
- H-VAL 310/410-ND-H-H night and day downstream pressure reduction with high sensitivity pilot.
- H-VAL 310/410-ND-H-5 night and day downstream pressure reduction with solenoid control.

### Working conditions

- Fluid: treated water.
- Minimum operating pressure: 0,7 bar.
- Maximum operating pressure: 16 bar.
- Maximum temperature: 70°C.

### Downstream pressure pilot adjustment range

- Blue spring: 0,7 to 7 bar.
- Red spring: 1,5 to 15 bar.



## Operating principle

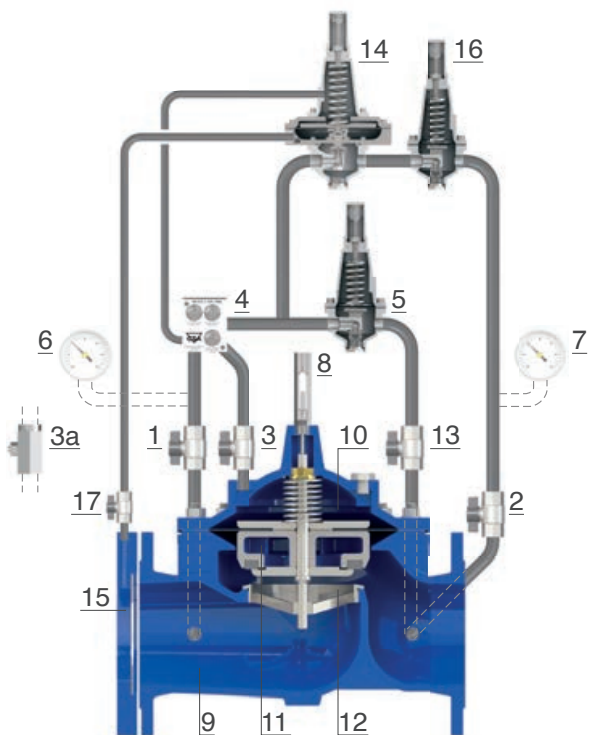

The valve is operated by two 2 ways pilot (5-16), for pressure reduction with pre-set set and adjustable values, activated by a third high accuracy flow sensing pilot (14), connected to a flanged orifice assembly located upstream (15). The flanged orifice is sized according to the application, user can then operate on the regulation screw to determine the flow above which the high pressure pilot will begin to work. Should it remain below such point the pilot (14) is closed diverting all flow and pressure to operate the lower pressure pilot (5). Once the flow has reached the triggering point pilot (14) will open allowing flow to circulate through the pilot (16), which will increase the pressure on the downstream side of the valve by closing the pilot (5), set to a lower value. The flow in and out of the main chamber (10) is controlled by the PF exclusive unit regulation device with filter called GR.I.F.O. (4) provided with three needle valves and flow stabilizers, needed for the valve's response time and accuracy also in case of rapid variation in demand.

## Installation layout

The recommended H-VAL 310/410-ND-H installation lay-out includes sectioning devices (1, 2) and by-pass for maintenance operations, and a filter (3) to prevent dirt from reaching the control valve. The direct acting pressure reducer W-VAL HP (4) is the best choice on the by-pass thanks to its reliability also after long periods of inactivity. Anti-surge combination air valves WAVE 3S-AWH (6, 7) are recommended upstream and downstream as well as a pressure relief valve WR/AM (5) to prevent rise in pressure on the line.







## Pressure reducing valve with Bluetooth remote control and two set points **Mod. H-VAL 310/410-ND-P**

The PF model H-VAL 310/410-ND-P is a globe pattern hydraulically operated automatic control valve that reduces and stabilizes the downstream pressure to two pre-set and adjustable values, regardless of variation in demands and upstream pressure conditions, usually corresponding to night and day regulation. Equipped with a Bluetooth remotely controlled programmer with EP68 case, and designed to reduce head loss, throttling noise and cavitation damage, the PF pressure reducing valve H-VAL 310/410-ND-P is extremely versatile and mainly used for pressure management and water loss reduction campaigns.

### Applications

- A well-planned pressure management program will extend the life of the system increasing safety and reliability. The automatic control valve PF H-VAL model 310/410-ND-P, thanks to the battery operated programmer EP68, managed by an intuitive app, is designed to automatically optimize the downstream pressure regulations in two steps, both adjustable, without having to access the location and controlled remotely.

### Accessories

- Linear position transmitter with 4-20 mA output Mod. PF CSPL.
- On-off position transmitter Mod. PF CSPO.
- Pressure measurement kit.
- Self-flushing and high capacity filter.

### Note to the engineer

- PF anti-cavitation low flow stability plugs are recommended in case of low flow.
- A minimum length of 3 DN downstream of the valve is recommended for the best accuracy.
- The programmer is battery operated with a Bluetooth and user friendly interface, different configurations and customized solutions available on request.

### Additional features

- H-VAL 310/410-ND-P-FR night and day pressure reduction with back-flow prevention.
- H-VAL 310/410-ND-P-H night and day downstream pressure reduction with high sensitivity pilot.
- H-VAL 310/410-ND-P-5 night and day downstream pressure reduction with solenoid control.

### Working conditions

- Fluid: treated water.
- Minimum operating pressure: 0,7 bar.
- Maximum operating pressure: 16 bar.
- Maximum temperature: 70°C.

### Downstream pressure pilot adjustment range

- Blue spring: 0,7 to 7 bar.
- Red spring: 1,5 to 15 bar.

## Operating principle

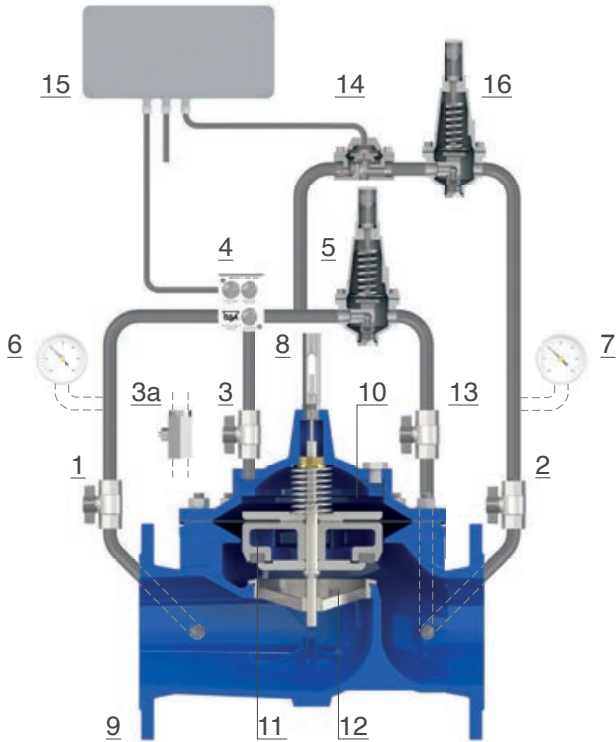

The valve is operated by two 2 ways pilot (5-16), for pressure reduction with pre-set set and adjustable values, activated by a control unit (15) acting on a flow accelerator (14). During night time regulation (low pressure) pilot 5 is working with the flow accelerator (14) in the closed position. Should the downstream pressure rise above the pilot (5) set point the latter will throttle and limit the flow to direct inlet pressure to the main chamber (10), to generate the head loss required for the valve (9) to reduce and stabilize the downstream pressure. During the day, or according to the customer's program of the unit (15), the pilot (16) is activated, and being its set point higher than the night time pilot (5) the latter will be forced to the closed position. The flow in and out of the main chamber (10) is controlled by the PF exclusive unit regulation device with filter called GR.I.F.O. (4) and provided with three needle valves and flow stabilizers, needed for the valve's response time and accuracy also in case of rapid variation in demand.

## Installation layout

The recommended H-VAL 310/410-ND-P installation lay-out includes sectioning devices (1, 2) and by-pass for maintenance operations, and a filter (3) to prevent dirt from reaching the control valve. The direct acting pressure reducer W-VAL HP (4) is the best choice on the by-pass thanks to its reliability also after long periods of inactivity. Anti-surge combination air valves WAVE 3S-AWH (6, 7) are recommended upstream and downstream as well as a pressure relief valve WR/AM (5) to prevent rise in pressure on the line.

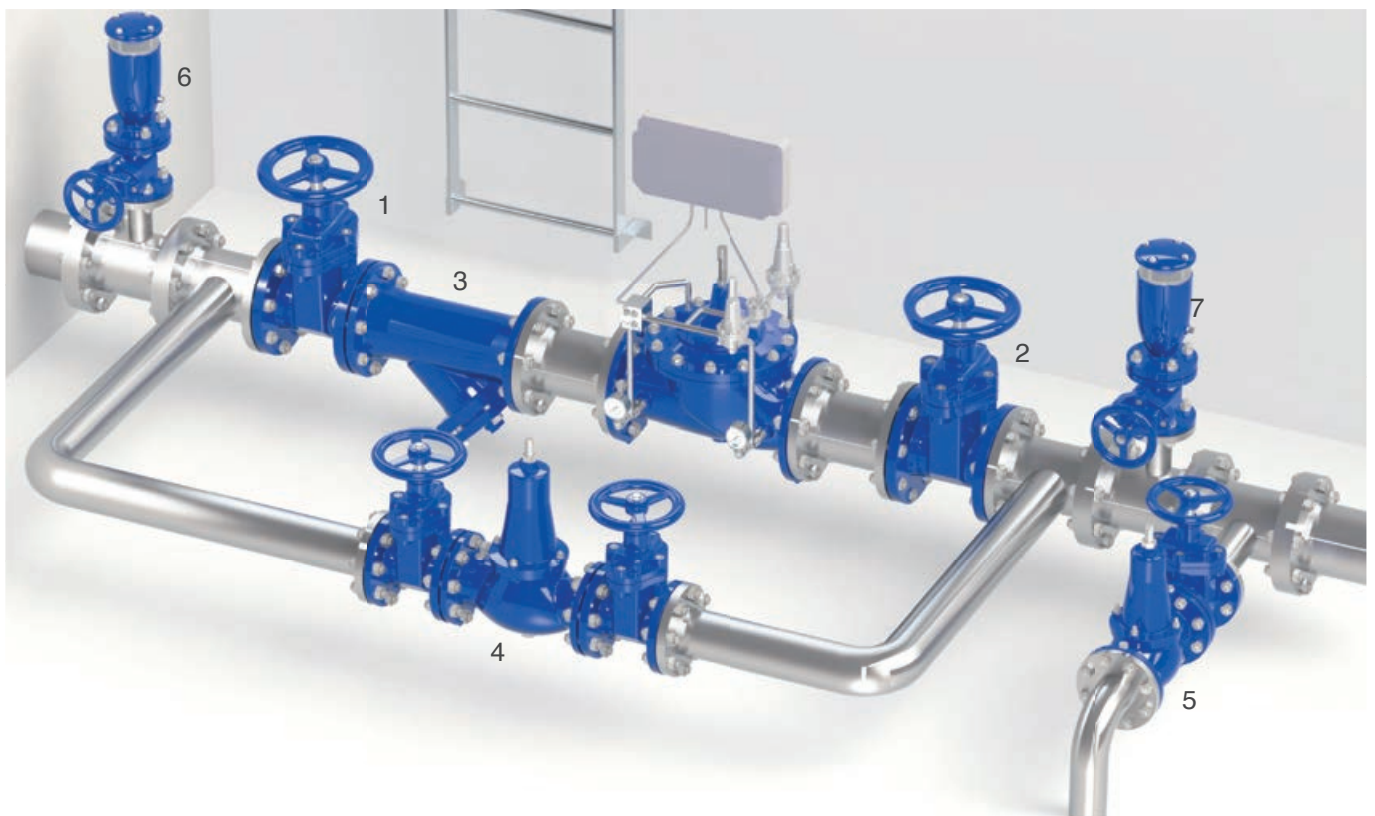

## Pressure management automatic control valve

### Mod. H-VAL 310/410-T



The PF model H-VAL 310/410-T automatic control valve reduces and stabilizes the downstream pressure correlating the pilot setting with demand, regardless of changes and fluctuations of upstream pressure conditions, through signals supplied by a PF controller or existing PLC either using a web interface or battery operated solutions. The PF pressure reducing stabilizing valve H-VAL 310/410-T stands out as the ideal solution for pressure management, and water loss reduction, as it can be interfaced with any existing SCADA and remote control system in addition to pressure sensors installed at the critical nodes and supply inlets.

#### Applications

- A well-planned pressure management program will extend the life of the system increasing safety and reliability. The PF H-VAL 310/410-T is designed to automatically optimize the downstream pressure with a real time adjustment as a function of demand, flow rate and pressure values at the critical nodes, obtained with PF controllers and web interface. Setting can be easily changed from remote from any portable device with a powerful and intuitive programming interface.

#### Accessories

- Linear position transmitter with 4-20 mA output Mod. PF CSPL.
- On-off position transmitter Mod. PF CSPO.
- Pressure measurement kit.
- Self-flushing and high capacity filter.

#### Note to the engineer

- Available with several PF controllers namely DC1, DC2, DC3 designed to be either power supplied to guarantee real time communication through web interface, or provided with battery and if required turbines, depending on the project requirements and the level of informations exchanged back and forth to the valve.

#### Additional features

- H-VAL 310/410-T-FR pressure management valve with back-flow prevention.
- H-VAL 310/410-T-H pressure management valve with high sensitivity pilot.
- H-VAL 310/410-T-5 pressure management valve with solenoid control.

#### Working conditions

- Fluid: treated water.
- Minimum operating pressure: 0,7 bar.
- Maximum operating pressure: 16 bar.
- Maximum temperature: 70°C.

#### Downstream pressure pilot adjustment range

- Blue spring: 0,7 to 7 bar.
- Red spring: 1,5 to 15 bar.
- Values lower than 0,7 available with high sensitivity pilots.



## Operating principle

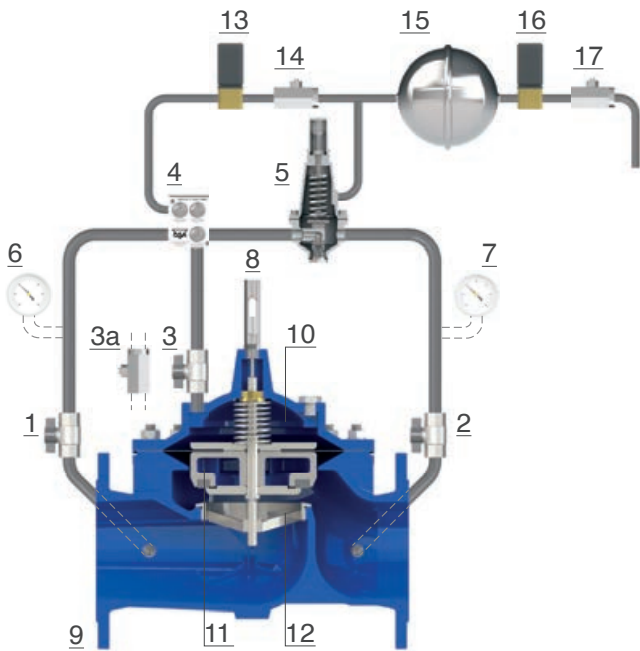

The PF model H-VAL 310/410-T is an automatic control valve operated by a 2 ways pilot (5) whose cover receives pressure from a secondary line, onto which two solenoids (13 and 16) are acting through signals from a PF controller linked to flow and pressure measurement devices. The purpose of this valve is to change the downstream pressure reduction set-point according to a flow rate curve that can be modified. Therefore should the system require an increase of the downstream pressure value the solenoid (13) will open in response to an impulse, vice-versa the 16 will decrease it by discharging pressure into atmosphere.

Needle valves (14, 17) and the buffer (15) are required to throttle the flow and improve the valve's stability. The flow in and out of the main chamber (10) is controlled by the PF exclusive unit regulation device with filter called GR.I.F.O. (4) and provided with three needle valves and flow stabilizers, needed for the valve's response time and accuracy also in case of rapid variation in demand.

## Installation layout

In the following installation lay-out the PF valve H-VAL 310/410-T (1) receives impulses from the PF controller (2), either power supplied or battery operated, working in combination with flow rate (3) and pressure measurement (4) devices (located near the valve or on critical points of the networks). Anti-surge combination air valves WAVE 3S-AWH (6, 7) are recommended upstream and downstream as well as a pressure relief valve, like PF direct acting model WR/AM (5) to prevent rise in pressure on the main line.

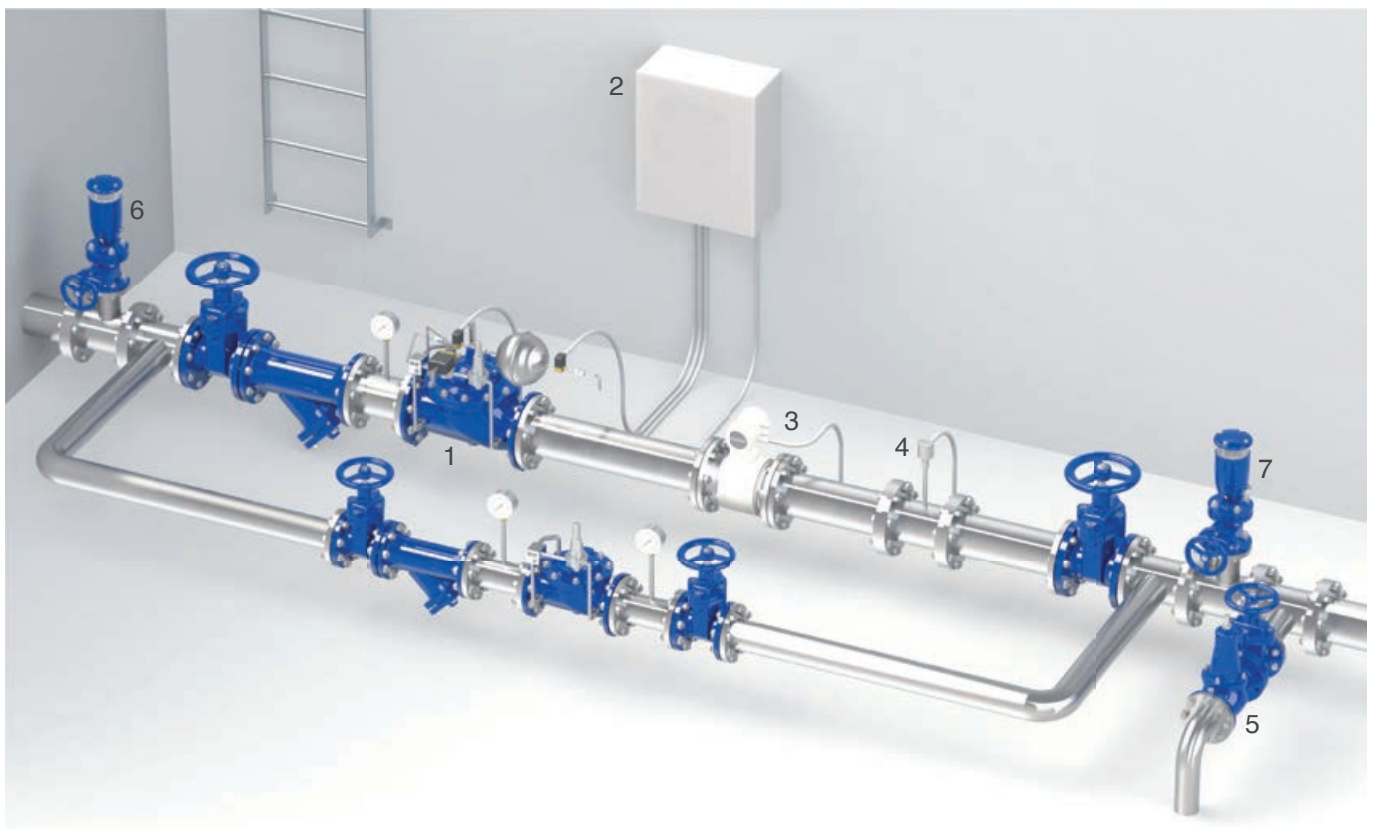





## Downstream pressure reducing and upstream pressure sustaining valve Mod. H-VAL 312/412

The PF Model H-VAL 312/412 is a globe pattern hydraulically operated automatic control valve with two independent functions. It sustains the upstream pressure to a minimum and pre-set value regardless of changes in demand, and it prevents at the same time the downstream pressure from rising above a maximum set-point. Both values are adjustable. Normally equipped with visual position indicator and made in ductile cast iron with FBT epoxy coating and stainless steel, the valve is designed to reduce head loss, throttling noise and cavitation damage.

### Applications

- Downstream of pumps to reduce pressure on the supply line and to prevent pump overload.
- To stabilize the pressure of secondary lines and avoid possible depressurization of the main transmission pipe.
- On gravity fed transmission lines to ensure a minimum operating pressure to consumers located upstream, preventing downstream pressure from rising above critical values in case of low consumption.

### Accessories

- Linear position transmitter with 4-20 mA output Mod. PF CSPL.
- On-off position transmitter Mod. PF CSPO.
- Pressure measurement kit.
- Self-flushing and high capacity filter.

### Note to the engineer

- Inlet and outlet pressure, flow rate are required for the proper sizing.
- PF anti-cavitation low flow stability plugs are recommended to provide an accurate regulation in case of low flow conditions.
- A minimum length of 3 DN downstream and upstream of the valve is recommended for the best accuracy.

### Additional features

- H-VAL 312/412-FR upstream pressure sustaining and downstream pressure reduction valve with back-flow prevention.
- H-VAL 312/412-H upstream pressure sustaining and downstream pressure reduction valve with high sensitivity pilot.
- H-VAL 312/412-5 upstream pressure sustaining and downstream pressure reduction valve with solenoid control.

### Working conditions

- Fluid: treated water.
- Minimum operating pressure: 0,7 bar.
- Maximum operating pressure: 25 bar.
- Maximum temperature: 70°C.

### Downstream and upstream pilots range

- Blue spring: 0,7 to 7 bar.
- Red spring: 1,5 to 15 bar
- Higher values up to 25 bar on request.
- For the pressure reduction pilot values lower than 0,7 available with high sensitivity pilots.

## Operating principle

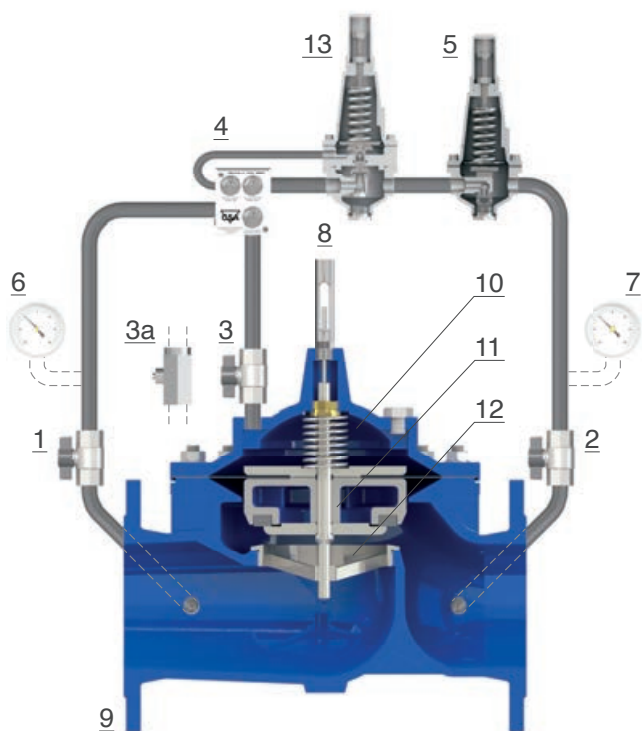

The PF model H-VAL 312/412 is an automatic control valve operated by two 2 ways pilots, respectively for the upstream pressure sustaining (13) and the downstream pressure reduction, (5) both with pre-set set and adjustable value. Should the upstream pressure fall below the master pilot's (13) set point the latter will throttle and limit the flow to direct inlet pressure to the main chamber (10), to sustain and stabilize the upstream pressure to a constant value. Should the upstream pressure be higher than the pilot's (13) set point the latter will open, allowing flow through the main valve (9) where at this point the pilot (5) will control and maintain the required downstream pressure. The flow in and out of the main chamber (10) is controlled by the PF exclusive unit regulation device with filter called GR.I.F.O. (4) and provided with three needle valves and flow stabilizers, needed for the valve's response time and accuracy also in case of rapid variation in demand.

## Installation layout

The H-VAL 312/412 installation lay-out includes sectioning devices (1, 2) and by-pass for maintenance, and a filter (3) to prevent dirt from reaching the control valve. The direct acting pressure sustaining WR/AM (8) and reducer W-VAL HP (4) are the best choice on the by-pass thanks to their reliability also after long periods of inactivity. Anti-surge combination air valves WAVE 3S-AWH (6, 7) are recommended upstream and downstream as well as an additional pressure relief valve WR/AM (5) to prevent rise in pressure on the line.

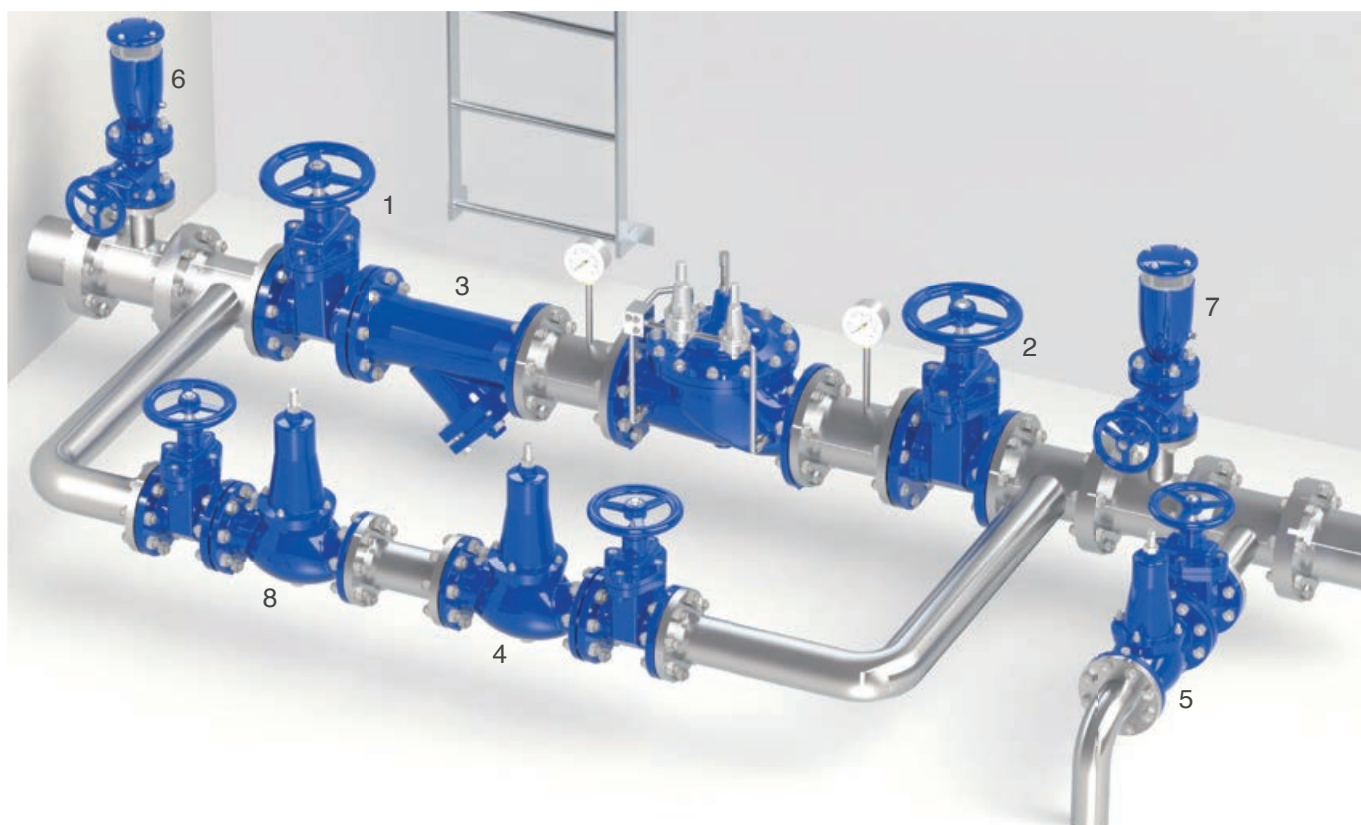



## Downstream pressure reducing stabilizing valve with solenoid control Mod. H-VAL 315/415

The PF model H-VAL 315/415 is a globe pattern hydraulically operated automatic control valve that reduces and stabilizes the downstream pressure to a constant value, regardless of variation in demands and upstream pressure conditions. Thanks to a solenoid control the valve will also open or close in response to a signal. Normally equipped with visual position indicator and entirely made in ductile cast iron with FBT epoxy coating and stainless steel, the valve is designed to reduce head loss, throttling noise and cavitation damage.

### Applications

- On the by-pass line of storage tank to ensure the required water supply and pressure control during maintenance.
- As a protection against rise in pressure of industrial equipments and civil installation with on-off control from remote for alarms and emergencies.
- Energy saving with controlled pumping and water supply hours.

### Accessories

- Linear position transmitter with 4-20 mA output Mod. PF CSPL.
- On-off position transmitter Mod. PF CSPO.
- Pressure measurement kit.
- Self-flushing and high capacity filter.

### Note to the engineer

- Inlet pressure, outlet pressure, flow rate and application are required for the proper sizing and cavitation analysis.
- PF anti-cavitation low flow stability plugs are recommended to provide an accurate regulation in case of low flow conditions.
- A minimum length of 3 DN downstream of the valve is recommended for the best accuracy.

### Additional features

- H-VAL 315/415-FR downstream pressure reduction valve with solenoid control and back-flow prevention system.
- H-VAL 315/415-H downstream pressure reduction and solenoid control with high sensitivity pilot.
- H-VAL 315/415-G downstream pressure reduction valve with solenoid control and over pressure guard system.

### Working conditions

- Fluid: treated water.
- Minimum operating pressure: 0,7 bar.
- Maximum operating pressure: 16 bar. Higher on request.
- Maximum temperature: 70°C.

### Downstream pressure pilot adjustment range

- Blue spring: 0,7 to 7 bar.
- Red spring: 1,5 to 15 bar
- Values lower than 0,7 available with high sensitivity pilots.

### Solenoid electrical data

- Voltages: 24 V DC, 24 V/50 Hz, 230 V/50 Hz. Other voltages on request.
- Power consumption: inrush AC (VA) 24, hold AC (VA) 17 (8 W), DC hot/cold coil 8/9 W.



## Operating principle

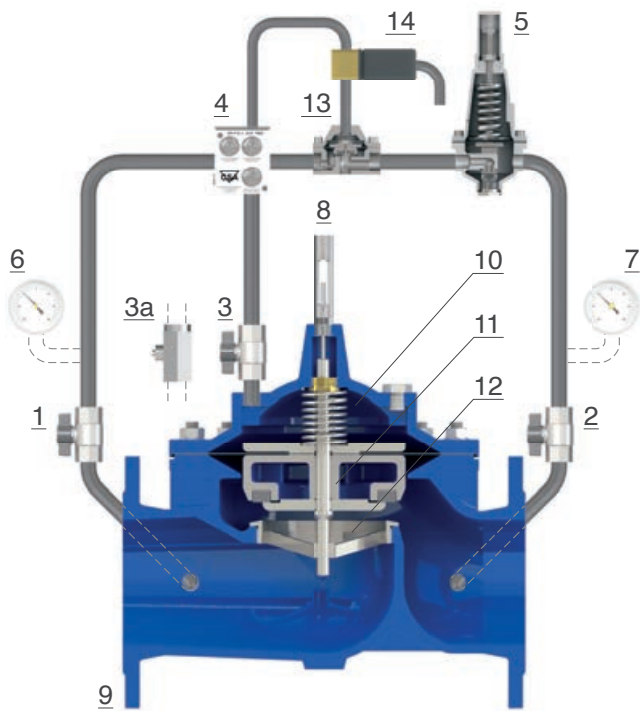

The PF Model H-VAL 315/415 is an automatic control valve operated by a two ways pilot (5), for downstream pressure reduction with pre-set adjustable value, and a solenoid valve (14) acting on a flow accelerator (13) to allow for normally open or normally closed function. Should the impulse to the solenoid (14) be set to have the flow accelerator (13) open if the downstream pressure rises above the pilot's set point (5) the latter will throttle, and limit the flow to divert line pressure to the main chamber (10), this to move the obturator down and generate the head loss required for the valve (9) to stabilize and maintain the desired downstream pressure. Should the downstream pressure fall below the pilot set point the obturator (11) will raise increasing the passage through the seat (12), reducing the head loss followed by the rise in pressure. The flow in and out of the main chamber (10) is controlled by the PF exclusive unit regulation device with filter called GR.I.F.O. (4) and provided with three flow stabilizers, needed for the valve's response time and accuracy.

## Installation layout

Sectioning devices (1, 2) and by-pass are very important for maintenance operations, as well as the filter (3) to prevent dirt from reaching the control valve. The valve is receiving impulses to the solenoid from a PF controller (8) or a remote signal. The direct acting pressure reducer W-VAL HP (4) is the best choice on the by-pass thanks to its reliability also after long periods of inactivity. Anti-surge air valves WAVE 3S-AWH (6, 7) are recommended as well as a pressure relief valve WR/AM (5), to prevent rise in pressure on the line.

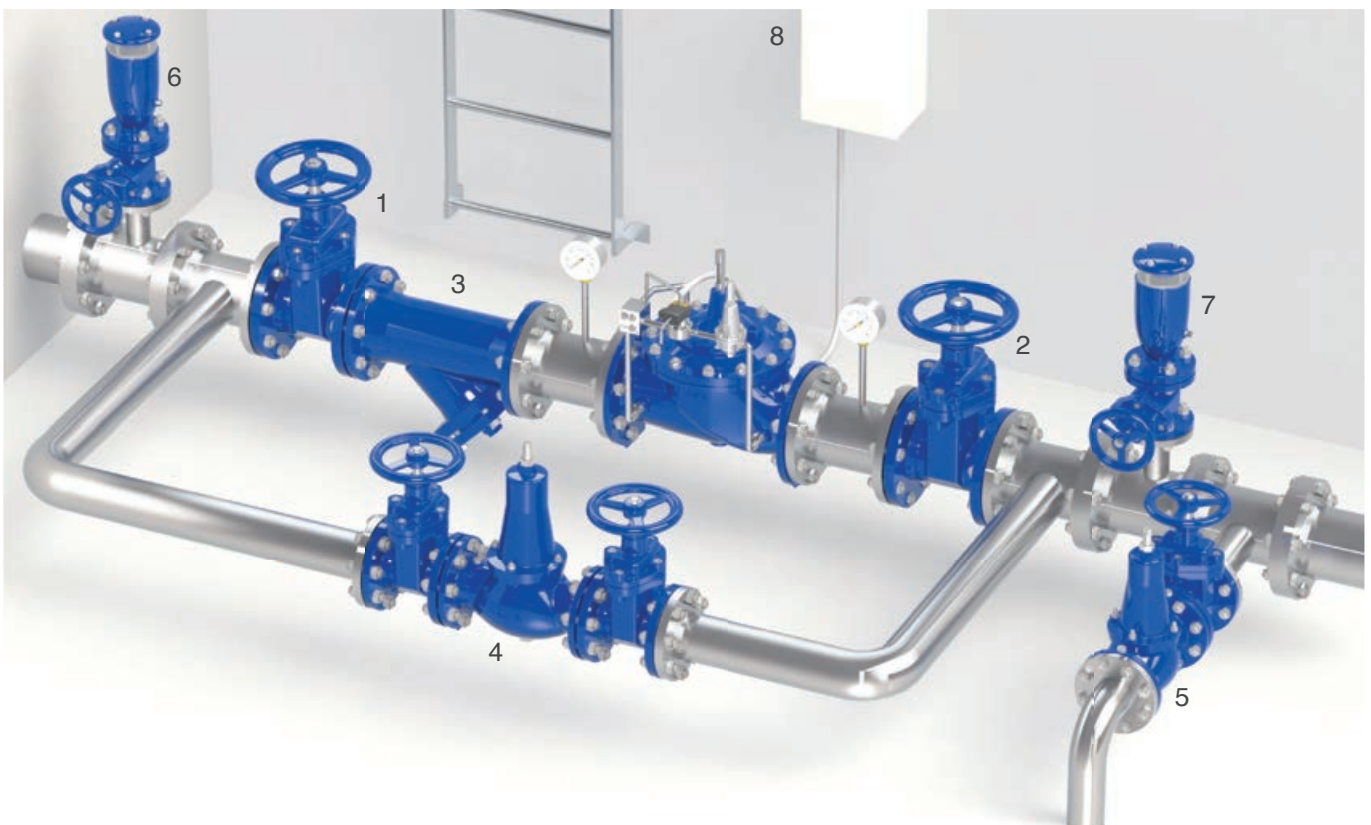





## Upstream pressure sustaining automatic valve Mod. H-VAL 320/420-S

The PF Model H-VAL 320/420-S is a globe pattern hydraulically operated automatic control valve that, installed in-line, will sustain the upstream pressure to a pre-set and adjustable value regardless of variations in demand. Normally equipped with visual position indicator and entirely made in ductile cast iron with FBT epoxy coating and stainless steel, the valve is designed to reduce head loss, throttling noise and cavitation damage. The H-VAL 320/420-S is extremely versatile and can be used for a wide range of applications in combination with several PF accessories and additional functions.

### Applications

- Downstream of pumps to prevent overload and for cavitation protection.
- On the inlet supply line of storage tanks to stabilize pressure and flow required for the level control.
- On gravity fed supply lines to ensure the minimum pressure to consumers located at higher elevation zones, in case of high consumption of the lower zones.

### Accessories

- Linear position transmitter with 4-20 mA output Mod. PF CSPL.
- On-off position transmitter Mod. PF CSPO.
- Pressure measurement kit.
- Self-flushing and high capacity filter.

### Note to the engineer

- Inlet pressure, outlet pressure, flow rate and application are required for the proper sizing and cavitation analysis.
- PF anti-cavitation low flow stability plugs are recommended to provide an accurate regulation in case of low flow conditions.
- A minimum length of 3 DN upstream of the valve is recommended for the best accuracy.

### Additional features

- H-VAL 320/420-S-FR pressure sustaining valve with back-flow prevention.
- H-VAL 320/420-S-5 pressure sustaining valve with solenoid control.
- H-VAL 320/420-S-H pressure sustaining valve with high sensitivity pilot.

### Working conditions

- Fluid: treated water.
- Minimum operating pressure: 0,7 bar.
- Maximum operating pressure: 25 bar.
- Maximum temperature: 70°C.

### Upstream pressure pilot adjustment range

- Blue spring: 0,7 to 7 bar.
- Red spring: 1,5 to 15 bar.
- Higher values up to 25 bar on request.

## Operating principle

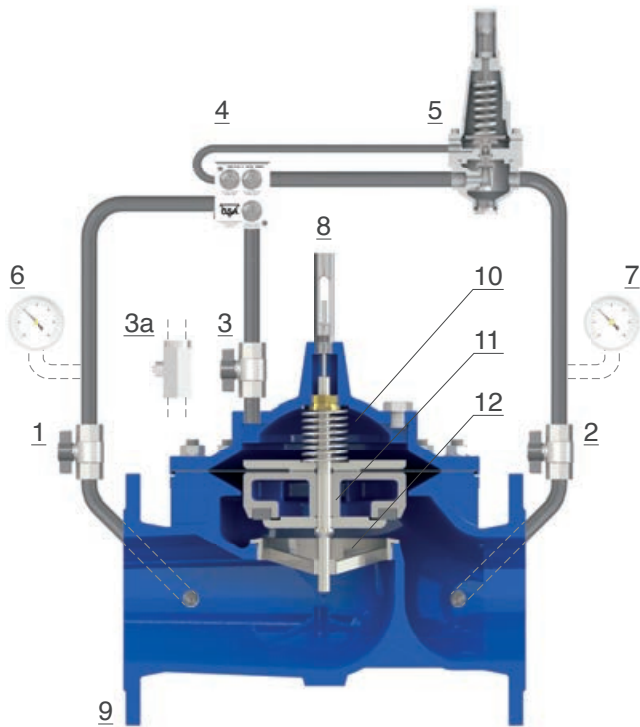

The PF Model H-VAL 320/420-S is an automatic control valve operated by a high sensitivity two ways pilot (5), with pre-set and adjustable set point value, sensing the upstream pressure from the GR.I.F.O. (4). Should the line pressure rise above the pilot's set point the latter will open thus relieving the chamber (10) and moving the obturator (11) upwards, to discharge water and pressure through the main valve (9) downstream protecting the system. Should the upstream pressure be lower than the pilot's set point the latter will throttle (close eventually) diverting all pressure towards the main chamber (10) thus pushing the obturator (11) onto the seat (12), interrupting the flow rate.

The flow in and out of the main chamber is controlled by the PF exclusive unit flow GR.I.F.O. (4) providing accuracy and absence of unwanted chattering.

## Installation layout

The recommended installation lay-out of the PF H-VAL 320/420-S, used as a pressure sustain in-line, includes sectioning devices (1, 2) and by-pass for maintenance operations, and a filter (3) to prevent dirt from reaching the control valve. The direct acting pressure sustain valve PF Mod. WR/AM (4) is the best choice on the by-pass thanks to its reliability also after long periods of inactivity. Anti-surge combination air valves PF Mod. WAVE 3S-AWH (5, 6) are recommended upstream and downstream of the installation.

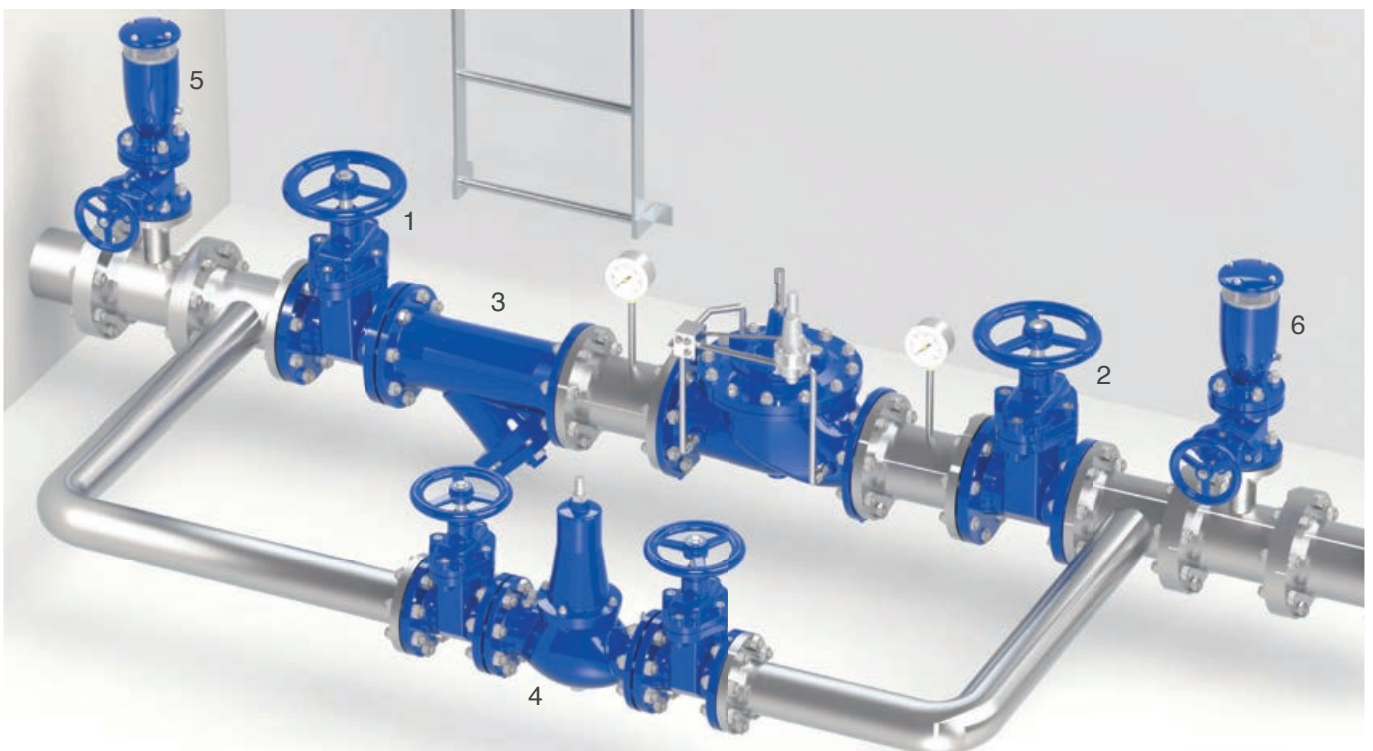



## Upstream pressure relief automatic valve Mod. H-VAL 320/420-R

The PF Model H-VAL 320/420-R is a globe pattern hydraulically operated automatic control valve that, installed in derivation from the main line, will relieve the excessive upstream pressure when it rises above the pre-set and adjustable value. Normally equipped with visual position indicator and entirely made in ductile cast iron with FBT epoxy coating and stainless steel, the valve is designed to reduce head loss, throttling noise and cavitation damage. The PF pressure relief valve H-VAL 320/420-R is extremely versatile and can be used for a wide range of applications in combination with several PF accessories and additional functions.

### Applications

- Downstream of pumps to protect the pipeline against rise in pressure during pump start up and pump failure.
- As a protection against rise in pressure in industrial equipment and civil installations.
- Downstream of pressure reducing station and modulating devices to protect the system against unwanted pressure fluctuations.

### Accessories

- Linear position transmitter with 4-20 mA output Mod. PF CSPL.
- On-off position transmitter Mod. PF CSPO.
- Pressure measurement kit.
- Self-flushing and high capacity filter.

### Note to the engineer

- Inlet pressure, outlet pressure, flow rate and application are required for the proper sizing and cavitation analysis.
- For the recommended flow rate, and operating conditions, please use the charts available on the H-VAL series engineering.
- When the valve discharges to atmosphere the AC (anti-cavitation) system is advised.

### Additional features

- H-VAL 320/420-R-FR upstream pressure relief valve with back-flow prevention.
- H-VAL 320/420-R-5 upstream pressure relief valve with solenoid control.
- The valve can be supplied without the GR.I.F.O. to increase the reaction time.

### Working conditions

- Fluid: treated water.
- Minimum operating pressure: 0,7 bar.
- Maximum operating pressure: 25 bar.
- Maximum temperature: 70°C.

### Pressure relief pilot adjustment range

- Blue spring: 0,7 to 7 bar.
- Red spring: 1,5 to 15 bar.
- Higher values up to 25 bar on request.



## Operating principle

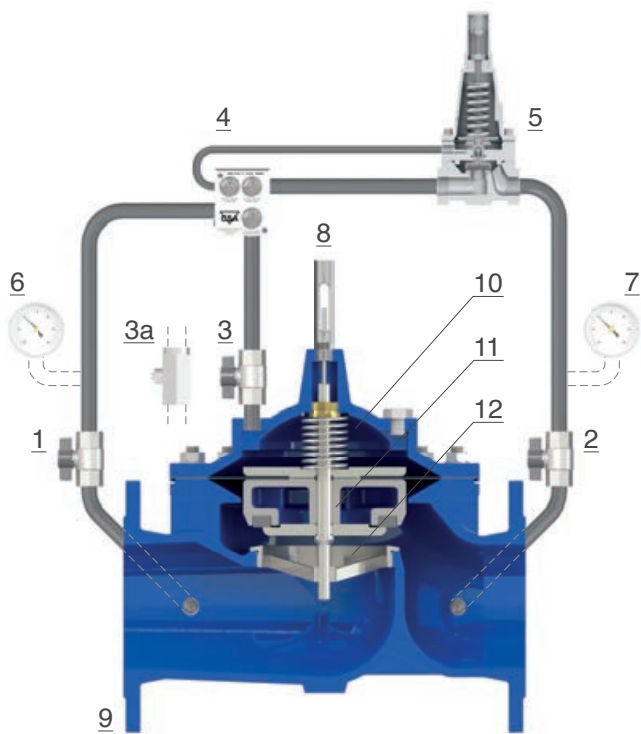

The PF Model H-VAL 320/420-R is an automatic control valve operated by a high flow capacity two ways pilot (5), with pre-set and adjustable set point value, sensing the upstream pressure from the GR.I.F.O. (4). Should the line pressure rise above the pilot's set point the latter will open thus relieving the chamber (10) and moving the obturator (11) upwards, to discharge water and pressure through the main valve (9) downstream protecting the system. Should the upstream pressure be lower than the pilot's set point the latter will throttle (close eventually) diverting all pressure towards the main chamber (10) thus pushing the obturator (11) onto the seat (12), interrupting the flow rate.

The flow in and out of the main chamber is controlled by the PF exclusive unit flow GR.I.F.O. (4) providing accuracy and absence of unwanted chattering.

## Installation layout

The picture below shows the recommended installation lay-out of the PF H-VAL 320/420-R, used as a pressure relief in derivation from the main line to protect a pumping station. The sectioning devices are very important for maintenance operations; whenever possible a filter too is needed to prevent dirt from reaching the control valve. The set point should always remain within 0,5-1 bar above the maximum steady state pressure value of the pumps.

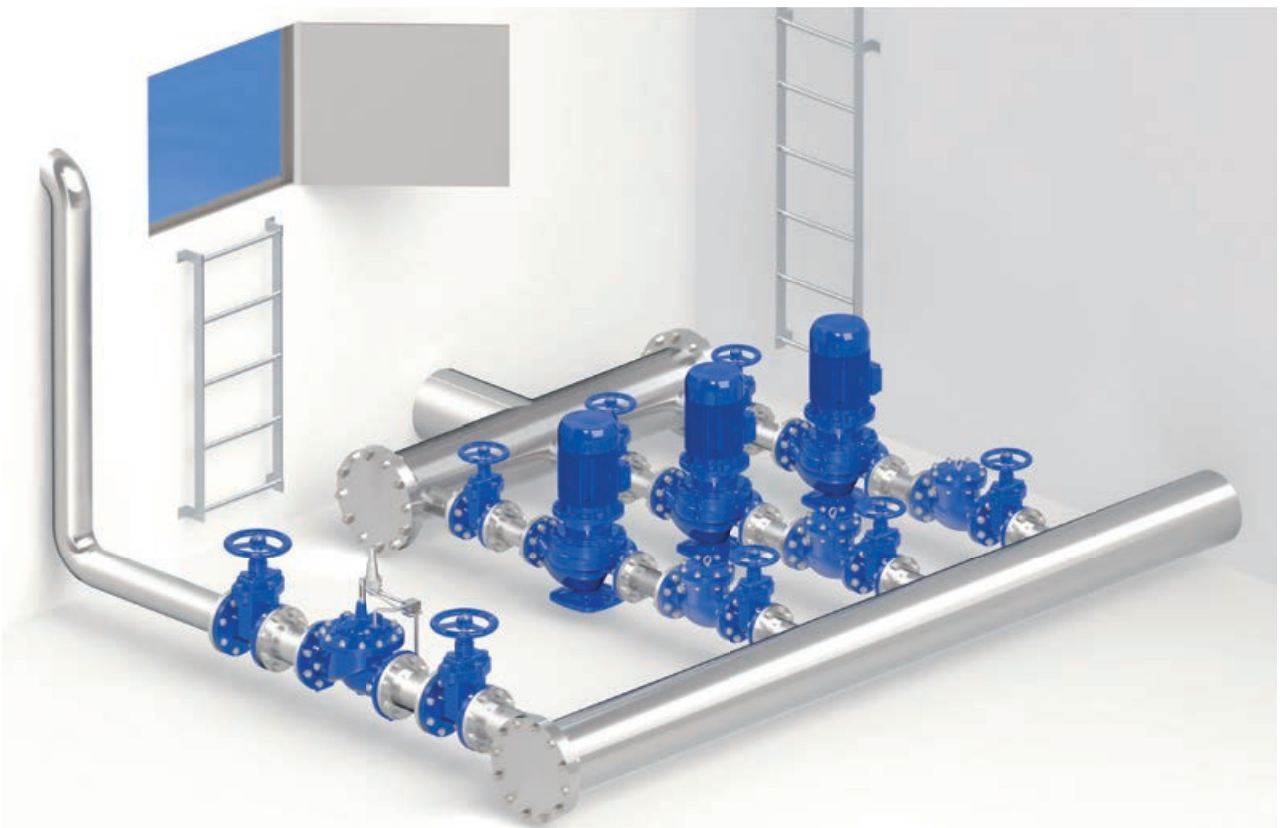



## Upstream pressure relief surge anticipating control valve Mod. H-VAL 321/421

The PF Model H-VAL 321/421, installed in derivation from the main line, will act as a protection of the system against the devastating effects of water hammer caused by pump failure. Thanks to a circuit composed of two pilots, hydraulic accelerators and PF exclusive flow control stabilizer, the valve will serve both as a pressure relief, in case of rise of pressure, and as an anticipator of water hammer in case of pump failure providing the valve with a response time almost instantaneous. For the proper sizing and water hammer analysis please contact PF.

### Applications

- At the pumping stations, downstream of pumps check valves in derivation from the main line.
- The valve is usually associated to PF anti-surge combination air valves WAVE 3S-AWH and other PF products chosen by the water hammer analysis.

### Accessories

- Linear position transmitter with 4-20 mA output Mod. PF CSPL.
- On-off position transmitter Mod. PF CSPO.
- Pressure measurement kit.
- Self-flushing and high capacity filter.
- CSFL mechanical flow regulator.

### Note to the engineer

- For the recommended flow rate, and operating conditions, please use the charts available on the H-VAL series engineering.
- PF needs the project data for a surge analysis which is highly recommended for the sizing and setting of H-VAL 321/421.
- The AC (anti-cavitation) system is always recommended for this kind of valve.

### Working conditions

- Fluid: treated water.
- Minimum operating pressure: 1,5 bar.
- Maximum operating pressure: 25 bar.
- Maximum temperature: 70°C.

### Upstream pressure pilot adjustment range

- Blue spring: 0,7 to 7 bar.
- Red spring: 1,5 to 15 bar.
- Higher values up to 25 bar on request.

### Pressure relief pilot adjustment range

- Red spring: 1,5 to 15 bar.
- Higher values up to 25 bar on request.







## Upstream pressure sustaining level control valve Mod. H-VAL 324/424

The PF Model H-VAL 324/424 is a globe pattern hydraulically operated automatic control valve that sustains the upstream pressure to a pre-set value regardless of variations in demand and, at the same time, it controls and regulates the minimum and maximum level inside a tank. Should the upstream pressure drop below the set point, during opening, the valve will throttle ensuring the water supply to higher zone consumers. The PF H-VAL 324/424 is extremely important to stabilize HGL, contain unwanted surges and to limit the excessive flow to the tank.

### Applications

- To prioritize high zone consumers during tank filling thanks to the upstream pressure sustaining function.
- On the inlet supply line of storage tanks to limit the flow required for the level control, in accordance with water demand patterns.
- On high rise buildings to ensure the proper regulation and control of rooftops reservoirs, avoiding possible overflow and damages, maintaining the required upstream pressure.

### Accessories

- Linear position transmitter with 4-20 mA output Mod. PF CSPL.
- On-off position transmitter Mod. PF CSPO.
- Pressure measurement kit.
- Self-flushing and high capacity filter.

### Note to the engineer

- Avoid possible high points and steep changes in slopes of the piping between the valve and the level control pilot.
- The AC (anti-cavitation) system is needed for application with static values above 7 bar, in this case consult with PF for the proper valve sizing.

### Additional features

- H-VAL 324/424-FR upstream pressure relief/sustaining valve with back-flow prevention.
- H-VAL 324/424-5 upstream pressure relief/sustaining automatic valve with solenoid control for electric float back-up.
- H-VAL 324/424-R upstream pressure relief/sustaining valve with surge prevention pilot.

### Working conditions

- Fluid: treated water.
- Minimum operating pressure: 0,7 bar.
- Maximum operating pressure: 16 bar.
- Recommended working pressure: 6 bar. Higher on request.
- Maximum temperature: 70°C.

### Upstream pressure pilot adjustment range

- Blue spring: 0,7 to 7 bar.
- Red spring: 1,5 to 15 bar.

### Level control pilot adjustment range

- Between 0,2 and 4 meters.

## Operating principle

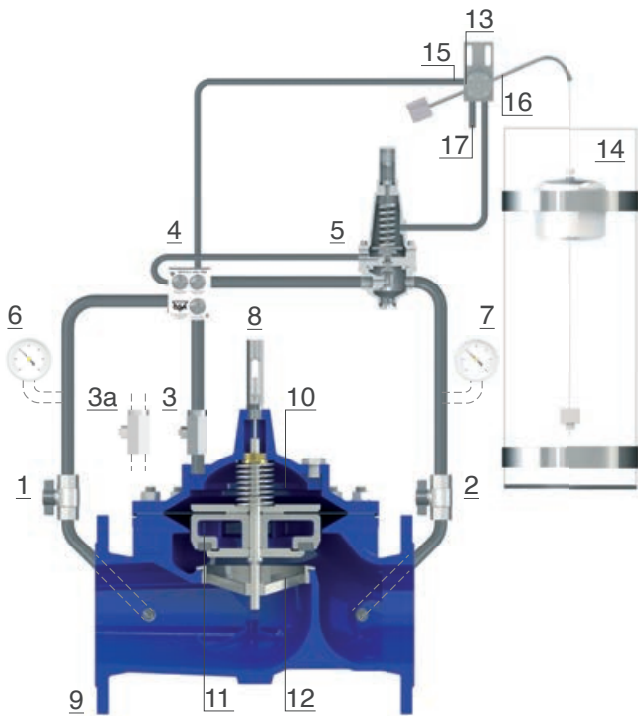

The H-VAL 324/424 is an automatic control valve operated by a two ways pilot for upstream pressure sustain (5) linked to a pilot for minimum and maximum level control (13), that can be installed inside the main tank or on an external stilling container (as per the picture). The valve is always closed when the level of the tank has reached the maximum, as all pressure will be diverted from upstream (1) to the cover of the pressure sustaining pilot (5) going through the three ways level control unit Rotoway (13). When water reaches the minimum level inside the tank the pressure of the pilot's cover (5) is relieved through the drain (17) of the three ways pilot (13), the main valve (9) will then sustain the line pressure to the minimum pre-set and adjustable value of the pilot (5). The flow in and out of the main chamber is controlled by the PF exclusive unit flow GR.I.F.O. (4) providing accuracy and absence of unwanted chattering.

## Installation layout

In the installation lay-out of the PF H-VAL 324/424, performing the level control through an external stilling tank (2), a maximum vertical distance of 4 meters is recommended between the valve and the maximum water level. The sectioning devices (1) are very important for maintenance operations; whenever possible a filter (3) too is needed to prevent dirt from reaching the control valve. Anti-surge air valves WAVE 3S-AWH are advised upstream of the valve for air release during working conditions and commissioning.





## Upstream pressure sustaining valve with solenoid control **Mod. H-VAL 325/425**

The PF Model H-VAL 325/425 is a globe pattern hydraulically operated automatic control valve that sustains the upstream pressure to a pre-set value regardless of variations in demand. Thanks to the solenoid control the valve will be able to close or open, in response to a signal sent from remote or by an external controller. Should the upstream pressure drop below the pilot set point the valve will close drip tight, assuring the proper operation also in static conditions.

### Applications

- On the inlet supply line of storage tanks, to control the flow and the level through an electric float.
- On gravity fed supply lines to prioritize the consumers at the higher elevation zones, with the safety of opening/closing according to signals/alarms.

### Accessories

- Linear position transmitter with 4-20 mA output Mod. PF CSPL.
- On-off position transmitter Mod. PF CSPO.
- Pressure measurement kit.
- Self-flushing and high capacity filter.

### Note to the engineer

- Inlet pressure, outlet pressure, flow rate and application are required for the proper sizing and cavitation analysis.
- PF anti-cavitation low flow stability plugs are recommended to provide an accurate regulation in case of low flow conditions.
- A minimum length of 3 DN upstream of the valve is recommended for the best accuracy.

### Additional features

- H-VAL 325/425-FR upstream pressure sustaining with solenoid control and back-flow prevention.
- H-VAL 325/425-R upstream pressure relief valve with fast acting pilot and solenoid control.
- H-VAL 325/425-H upstream pressure sustaining valve with high sensitivity pilot and solenoid control.

### Working conditions

- Fluid: treated water.
- Minimum operating pressure: 0,7 bar.
- Max. operating press.: 16 bar. Higher on request.
- Maximum temperature: 70°C.

### Upstream pressure pilot adjustment range

- Blue spring: 0,7 to 7 bar.
- Red spring: 1,5 to 15 bar.
- Higher values up to 25 bar on request.
- Values lower than 0,7 available on request.

### Solenoid electrical data

- Voltages: 24 V DC, 24 V/50 Hz, 230 V/50 Hz. Other voltages on request.
- Power consumption: inrush AC (VA) 24, hold AC (VA) 17 (8 W), DC hot/cold coil 8/9 W.



## Operating principle

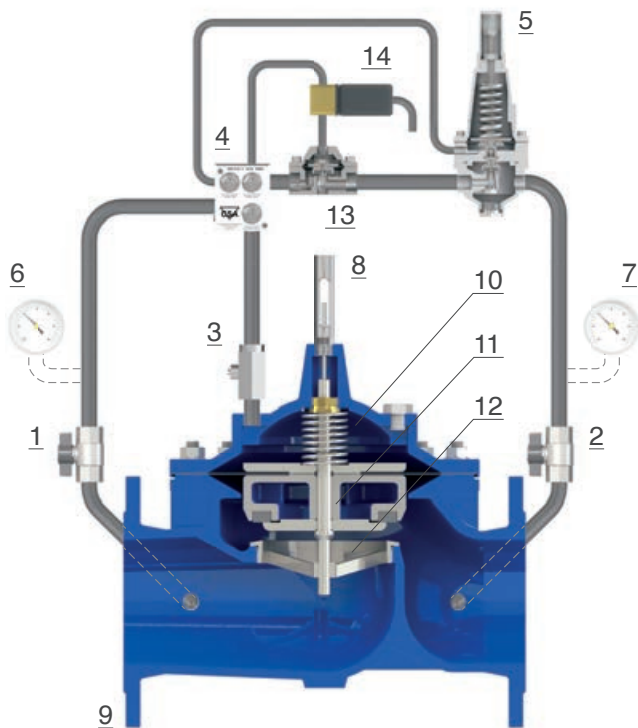

The PF Model XLC 325/425 is an automatic control valve operated by a two ways pilot (5), sensing the line pressure through the GR.I.F.O. and a solenoid (14) acting on a flow accelerator (13). Should the upstream pressure rise above the pilot's set point the latter will open relieving the control chamber (10) and lifting up the obturator allowing flow through the main valve (9). If the line pressure drops below the pilot's set point the latter will throttle diverting pressure towards the main chamber (10), to push the obturator downwards in order to create the head loss required for pressure sustaining function. The solenoid (14) will interrupt the flow through the circuit, closing the accelerator (13), in response to signals coming from a PF controller or from remote.

The flow in and out of the main chamber is controlled by the flow stabilizer GR.I.F.O. (4) providing accuracy and absence of chattering.

## Installation layout

In the following picture the PF H-VAL 325/425 is linked to a PF controller (7) or any other electronic device sending impulses to the solenoid on the circuit. Sectioning devices (1, 2) and by-pass are needed for maintenance operations, and a filter (3) to prevent dirt. The pressure sustaining valve WR/AM (4) is the best choice on the by-pass thanks to its reliability also after long periods of inactivity. Anti-surge air valves WAVE 3S-AWH (5, 6) are recommended upstream and downstream of the installation.

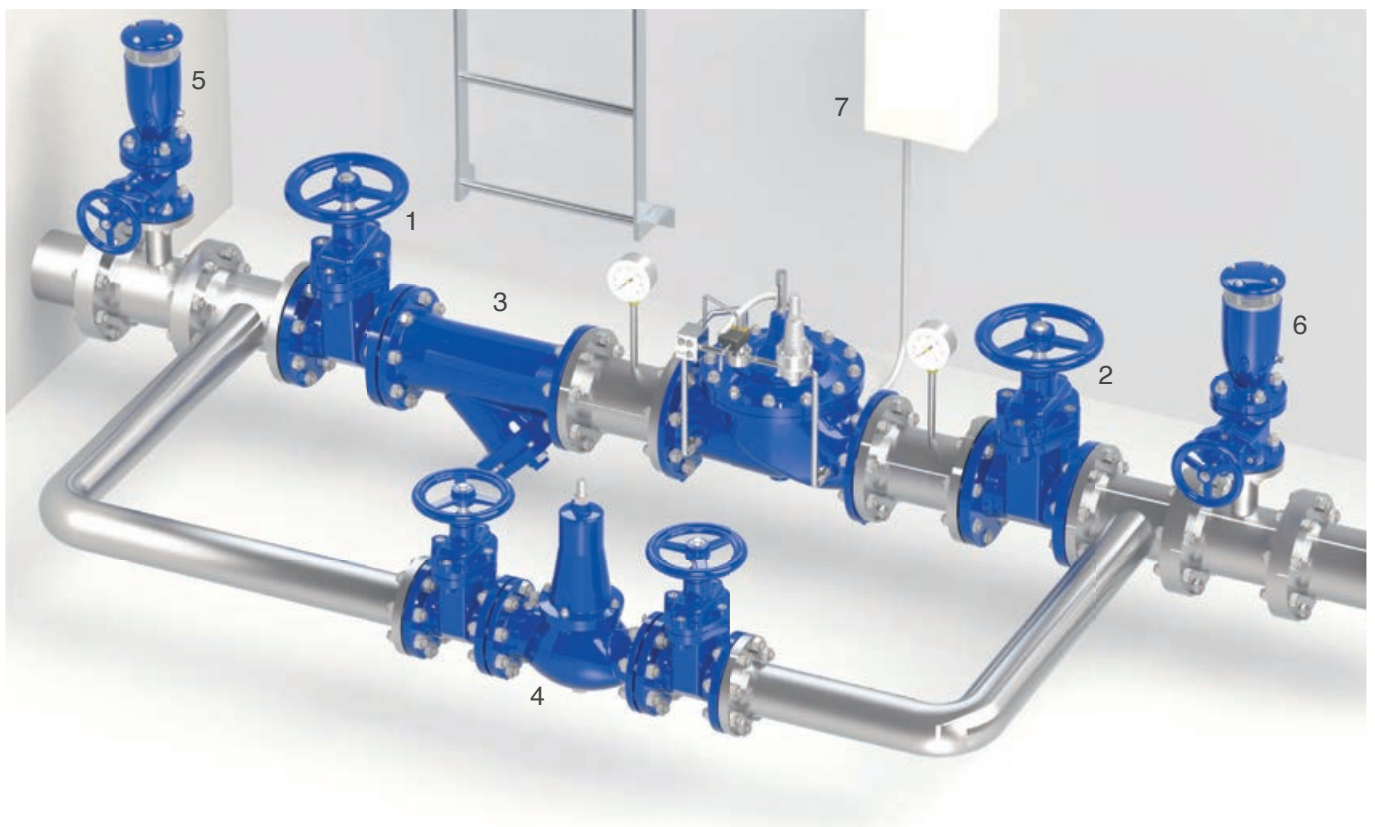



## Upstream pressure sustaining constant level control valve Mod. H-VAL 326/426

The PF Model H-VAL 326/426 is a globe pattern hydraulically operated automatic control valve that sustains the upstream pressure to a minimum value and at the same time regulates the constant level of a tank, regardless of upstream pressure variations. Thanks to a needle valve on the chamber the response time can be adjusted, to prevent water hammer effects during the closing phase. Normally equipped with visual position indicator and entirely made in ductile cast iron with FBT epoxy coating and stainless steel, the valve is designed to reduce head loss, throttling noise and cavitation damage.

### Applications

- For break pressure tanks and when a proportional level control is needed within the pilot's range.
- For level control on gravity fed pipelines.
- For small tank and in need of maintaining a constant level with a continuous modulating without excessive drop in pressure.

### Accessories

- On-off position transmitter Mod. PF CSPO.
- Pressure measurement kit.
- Self-flushing and high capacity filter.
- PF anti-cavitation low flow stability plugs are recommended to provide an accurate regulation in case of low flow conditions.
- CSFL mechanical flow regulator.

### Note to the engineer

- Avoid bends and high points on the piping to connect the main valve to the level control pilot to prevent the formation of air pockets.
- For the proper functioning a minimum of 1 bar on the level control pilot is needed, failing in doing so would create delays and malfunctioning.

### Additional features

- H-VAL 326/426-FR pressure sustaining and constant level valve with back-flow prevention.
- H-VAL 326/426-R pressure sustaining and constant level valve with surge prevention pilot.

### Working conditions

- Fluid: treated water.
- Minimum operating pressure: 1 bar on the level control pilot.
- Maximum operating pressure: 16 bar.
- Recommended working pressure: 6 bar. Higher on request.
- Maximum temperature: 70°C.

### Upstream pressure pilot adjustment range

- Blue spring: 0,7 to 7 bar.
- Red spring: 1,5 to 15 bar.
- Higher values up to 25 bar on request.

### Constant level pilot adjustment range

- 85 mm as a standard, different on request.

## Operating principle

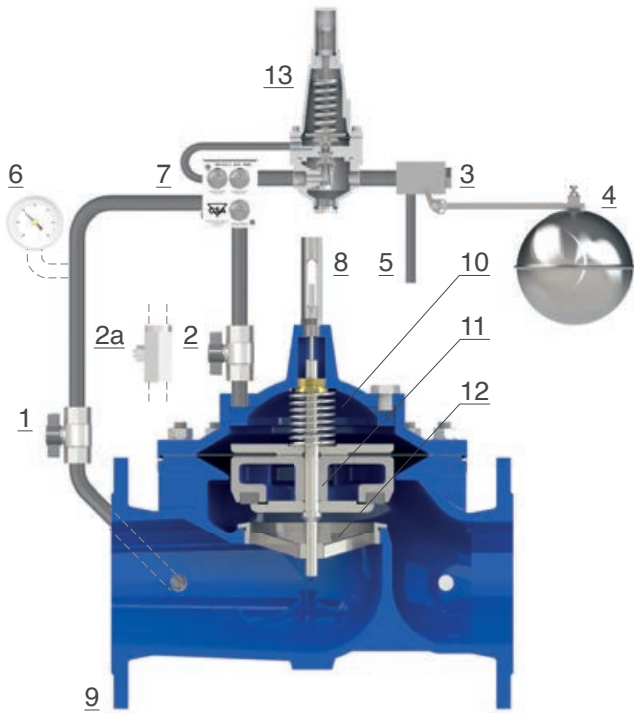

The PF model H-VAL 326/426 is operated by two pilots in series where the first is the (13) pressure sustaining unit followed by a control level proportional pilot (3). The first (13) will open in case of incoming pressure higher than the set point, closing and diverting flow towards the chamber (10), should the upstream pressure fall below the set point. If the level drops inside the tank due to consumption the proportional pilot (3) will open through the drain (5) discharging the main chamber (10), to generate a passage through the seat (12) in proportion to the demand, lifting the obturator (11) upwards accordingly. Should the tank level rise due to the refilling the pilot (3) will modulate, throttling the flow through the drain (5) and, if required, closing the valve. The water flow goes in and out of the chamber (10) through the exclusive unit flow control device GR.I.F.O. (7), provided with three adjustable needles valves and check valves for the regulation of the opening and closing speed, independently of one another, needed for the valve's response time and accuracy.

## Installation layout

The H-VAL 326/426 is linked to the level pilot (2) through a single pipe. Sectioning devices (1) are recommended for maintenance and a filter (3) is needed upstream, to prevent dirt from entering the main valve, affecting the performance. The constant level control pilot (2) should always be located in a position away from the water surface turbulence created by the inlet supply pipe to the tank. In case of static values higher than 6 bar the AC (anti-cavitation) system and a PF pressure reducer W-VAL HP are advised.







## Differential pressure sustaining valve Mod. H-VAL 395/495

The PF Model H-VAL 395/495 is a globe pattern hydraulically operated automatic control valve that sustains a minimum upstream pressure differential value between two points, pre-set and adjustable, regardless of variations in demand. Entirely made in ductile cast iron with FBT epoxy (fluid bed technology) coating with internals in stainless steel, the valve has been designed to reduce head loss, throttling noise and cavitation damage.

### Applications

- On the main supply line of pumping stations to prevent overload and to avoid cavitation.
- On cooling systems for pressure balancing between circuits.
- On filtration systems for emergency by-pass.

### Accessories

- Linear position transmitter with 4-20 mA output Mod. PF CSPL.
- On-off position transmitter Mod. PF CSPO.
- Pressure measurement kit.
- Self-flushing and high capacity filter.

### Note to the engineer

- Inlet pressure, outlet pressure, flow rate and application are required for the proper sizing and cavitation analysis.
- For flow rate and operating conditions use the charts on H-VAL series engineering.
- A minimum length of 3 DN upstream of both pressure ports is recommended for the proper operation and the best accuracy.

### Additional features

- H-VAL 395/495-FR differential upstream pressure sustaining valve with back-flow prevention.
- H-VAL 395/495-5 differential upstream pressure sustaining valve with solenoid control.

### Working conditions

- Fluid: treated water.
- Minimum operating pressure: 0,7 bar.
- Maximum operating pressure: 25 bar.
- Maximum temperature: 70°C.

### Upstream pressure pilot adjustment range

- Blue spring: 0,7 to 7 bar.
- Red spring: 1,5 to 15 bar.
- Higher values up to 25 bar on request.
- Values lower than 0,7 available on request.

## Operating principle

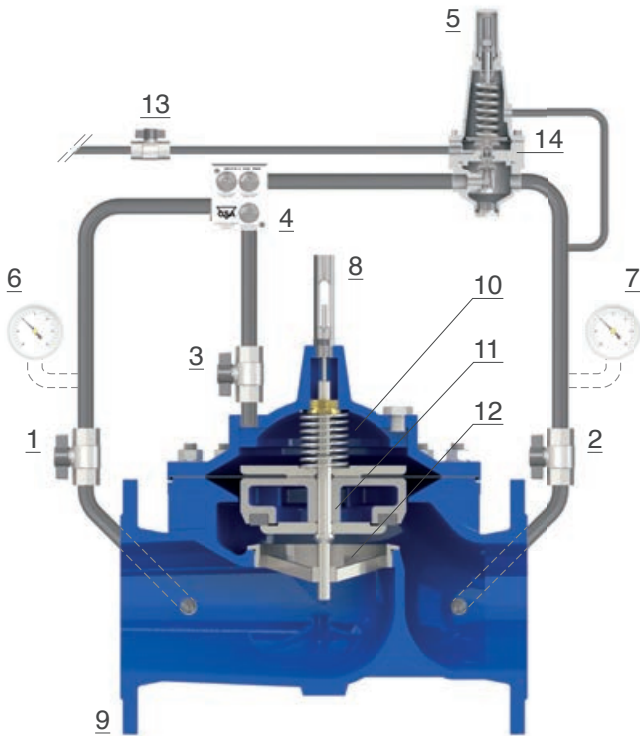

The PF Model H-VAL 395/495 is operated by a two ways pilot (5), with pre-set and adjustable set point value, sensing two pressures points in order to maintain a required differential between them. The first point is actually the downstream pressure (7) acting on the pilot's cover, while the second (13) is the upstream pressure, sensed either upstream or through an external port away from the valve, and connected to the pilot's intermediate body (14). Both values are required for the valve to work, creating the differential pressure needed for the design, whose circuit is controlled by the exclusive PF unit flow control device GR.I.F.O (4) for the best accuracy and proper response time. Should the difference in pressure rise above the pilot's set point the latter will open thus discharging the main chamber (10) and moving the obturator (11) towards the open position. Should the difference in pressure be lower than the pilot's set point the latter will throttle, diverting all pressure towards the main chamber (10) thus pushing the obturator (11) onto the seat (12) and reducing the flow rate through the main supply line.

## Installation layout

The picture shows the installation lay-out of the PF H-VAL 395/495 used for pump control, to avoid overload and cavitation, where pressure is taken before and after the pump (1) in order to maintain the required difference in pressure. In case of by-pass, needed for maintenance, the pressure sustaining valve WR/AM (2) is the best choice thanks to its reliability also after long periods of inactivity. Anti-surge combination air valves WAVE 3S-AWH (3, 4) are recommended upstream and downstream of the installation.

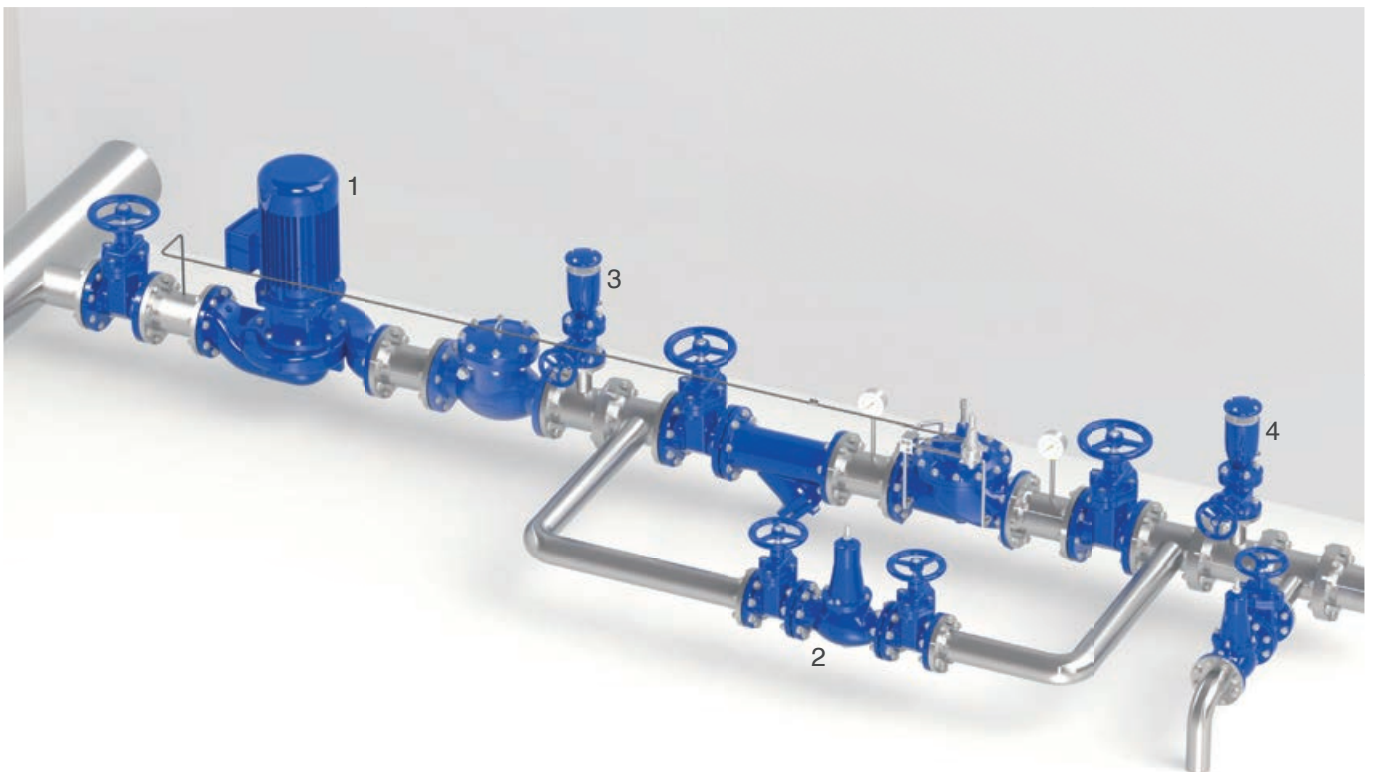



## Flow rate automatic control valve Mod. H-VAL 330/430

The PF model H-VAL 330/430 is a globe pattern hydraulically operated automatic control valve that limits the flow to a pre-set value, regardless of pressure variations. In case of flow rate lower than the required set point the valve will be fully opened. The valve is supplied with an orifice plate assembly, needed for the proper functioning and connected to the pilot. Normally equipped with visual position indicator and entirely made in ductile cast iron with FBT (fluid bed technology) epoxy coating and stainless steel, the valve is designed to reduce head loss, throttling noise and cavitation damage.

### Applications

- Downstream of pumps to prevent overload and for cavitation protection.
- On the inlet supply lines of tanks to prevent excessive flow.
- In distribution networks and on the supply lines of residential and industrial districts to limit the flow during peak hours.
- In filtration systems to prevent excessive flow avoiding damages and malfunctioning.

### Accessories

- Linear position transmitter with 4-20 mA output Mod. PF CSPL.
- On-off position transmitter Mod. PF CSPO.
- Pressure measurement kit.
- Self-flushing and high capacity filter.

### Note to the engineer

- Inlet and outlet pressure, flow rate are required for the proper sizing.
- PF anti-cavitation low flow stability plugs are recommended to provide an accurate regulation in case of low flow conditions.
- For the best accuracy leave 5 DN between the valve and the orifice plate and 3 DN downstream of it (picture in the next page).

### Additional features

- H-VAL 330/430-FR flow rate control valve with back-flow prevention.
- H-VAL 330/430-H flow rate control valve with high sensitivity pilot.

### Working conditions

- Fluid: treated water.
- Minimum operating pressure: 1,2 bar.
- Maximum operating pressure: 16 bar. Higher on request.
- Maximum temperature: 70°C.

### Flow rate control pilot adjustment range

- The orifice plate assembly is calculated and machined according to the maximum flow rate. An adjustment range of the value is possible according to the regulation flow chart supplied with the valve.



## Operating principle

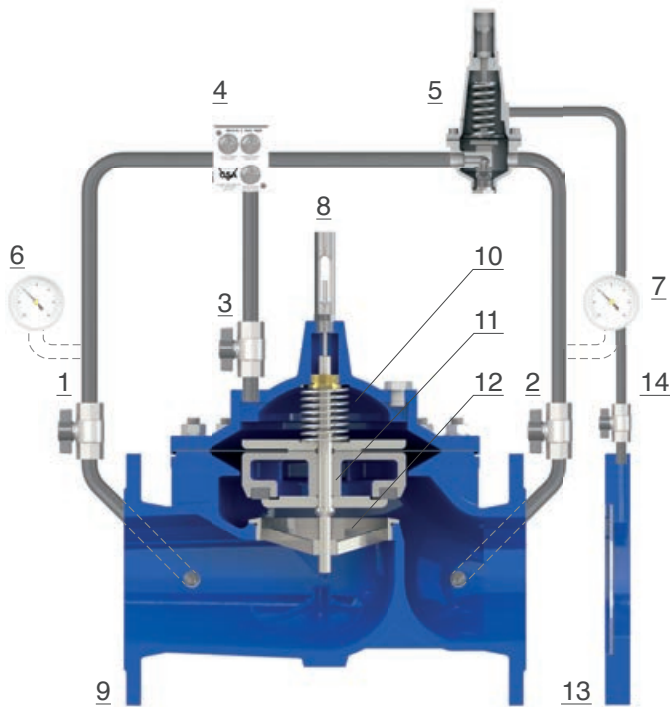

The PF model H-VAL 330/430 is operated by a two ways pilot (5), for flow control, with pre-set set and adjustable values, sensing the drop in pressure produced by the orifice plate (13), where a stainless steel disk is inserted inside a flange and connected to the pilot with a sensing line (14) non supplied.

Should the flow exceed the maximum value the differential pressure will increase and pilot (5) will throttle and limit the flow to direct inlet pressure to the main chamber (10), to generate the head loss required through the seat (12) for the valve (9) to control the flow. Should the flow remain below the pilot's set point, the differential pressure across the orifice plate (13) will be less than the pilot's (5) spring force, therefore the valve will remain fully open.

Pressure in and out of the main chamber (10) is controlled by the PF exclusive regulation device with filter called GR.I.F.O. (4), needed for the valve's response time and accuracy.

## Installation layout

The picture shows the recommended lay-out of the PF H-VAL 330/430. The flange orifice (8), calculated and machined according to the project's requirements, is connected to the valve's pilot (9). Sectioning devices (1, 2) and by-pass are very important for maintenance operations, as well as the filter (3) to prevent dirt from reaching the control valve. Anti-surge combination air valves WAVE 3S-AWH (6, 7) are recommended, as well as a pressure relief valve, like PF WR/AM (5) to prevent rise in pressure on the main line.

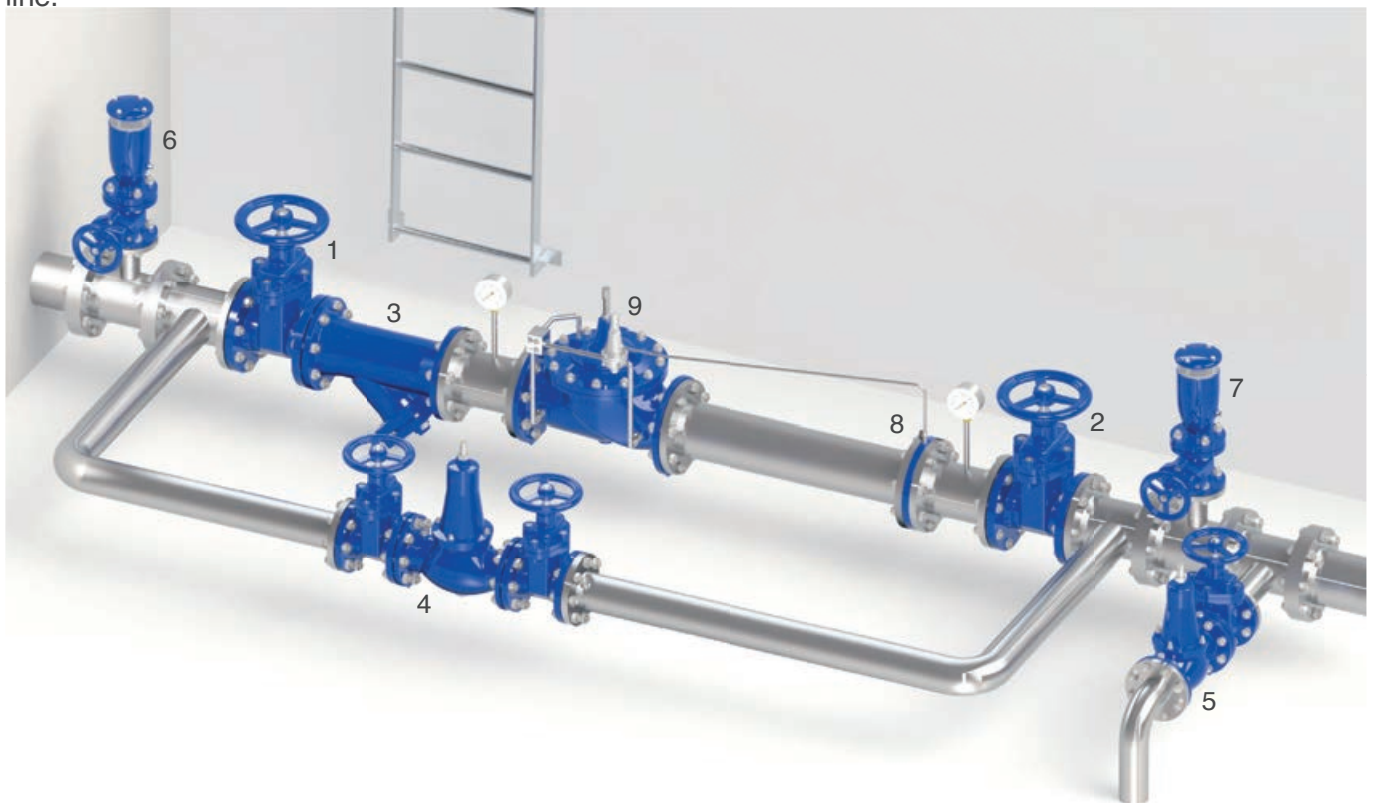



## Flow control and pressure reducing automatic valve

### Mod. H-VAL 331/431

The PF model H-VAL 331/431 is a globe pattern hydraulically operated automatic control valve that reduces and stabilizes the downstream pressure to a constant set-point, regardless of variation in demands, limiting at the same time the flow rate to a maximum value. Normally equipped with visual position indicator and made in ductile cast iron with FBT (fluid bed technology) epoxy coating and stainless steel, the valve reduces head loss, throttling noise and cavitation damage. The valve is supplied with an orifice plate assembly, needed for the proper functioning and connected to the pilot.

#### Applications

- Downstream of pumps to reduce the pressure and prevent overload.
- As a protection against rise in pressure of industrial equipment, plants and civil installations, limiting the flow to prioritize high zones consumers.
- In filtration systems to prevent excessive flow and unwanted rise in pressure avoiding damages and malfunctioning.

#### Accessories

- Linear position transmitter with 4-20 mA output Mod. PF CSPL.
- On-off position transmitter Mod. PF CSPO.
- Pressure measurement kit.
- Self-flushing and high capacity filter.

#### Note to the engineer

- Inlet and outlet pressure, flow rate are required for the proper sizing.
- PF anti-cavitation low flow stability plugs are recommended to provide an accurate regulation in case of low flow conditions.
- For the best accuracy leave 5 DN between the valve and the orifice plate and 3 DN downstream of it (picture in the next page).

#### Additional features

- H-VAL 331/431-FR pressure reduction and flow control valve with back-flow prevention.
- H-VAL 331/431-H pressure reduction and flow control valve with high sensitivity pilot.
- H-VAL 331/431-5 pressure reduction and flow control valve with solenoid control.

#### Working conditions

- Fluid: treated water.
- Minimum operating pressure: 1,5 bar.
- Maximum operating pressure: 16 bar. Higher on request.
- Maximum temperature: 70°C.

#### Downstream pressure pilot adjustment range

- Red spring: 1,5 to 15 bar.

#### Flow rate control pilot adjustment range

- The orifice plate assembly is calculated and machined according to the maximum flow rate. An adjustment range of the value is possible according to the regulation flow chart supplied with the valve.

## Operating principle

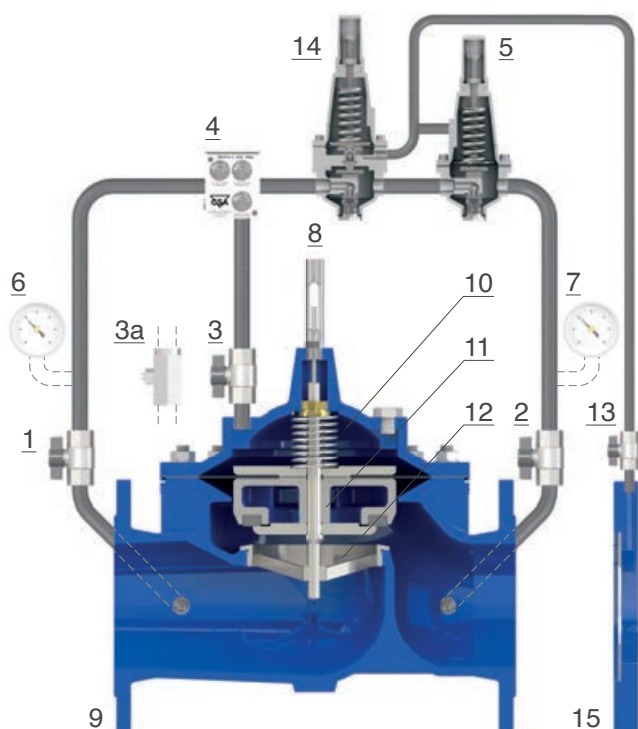

The PF model H-VAL 331/431 is operated by two 2 ways pilots (14-5), namely for pressure reduction and flow control, with pre-set and adjustable values. The downstream pressure is sensed after the orifice plate assembly (15). Should the downstream pressure rise above the pilot (14) set-point the latter will throttle and limit the flow to direct inlet pressure to the main chamber (10), to reduce and stabilize the downstream pressure to a constant value. Should the downstream pressure fall below the pilot set-point the obturator (11) will raise, to reduce the head loss followed by the rise in pressure. The flow rate control pilot (5) receives the downstream pressure on the cover where the spring is adjusted to compensate the difference in pressure produced by the orifice plate assembly. Should the flow exceed the maximum value the pilot (5) will throttle and limit the flow to direct inlet pressure to the main chamber (10), to generate the head loss required for flow control. The PF regulation device with filter called GR.I.F.O. (4) guarantees the valve's response time and accuracy.

## Installation layout

The installation lay-out of the PF H-VAL 331/431 includes sectioning devices (1, 2) and by-pass, with PF direct acting pressure control valves (4), very important for maintenance operations. The orifice plate assembly (8) needs to be located 5 DN downstream of the valve leaving 3 DN more before any change in direction, slope and cause of turbulence in the fluid. WAVE 3S-AWH (6, 7) are recommended for air release and commissioning as well as pressure relief valve PF WR/AM (5) to prevent rise in pressure on the line.







## Flow regulation valve with minimum-maximum level control Mod. H-VAL 334/434

The PF Model H-VAL 334/434 is a globe pattern hydraulically operated automatic control valve that controls the minimum and maximum level of a tank limiting, at the same time, the maximum flow to a requested value regardless of pressure variations.

Normal equipped with visual position indicator and made in ductile cast iron with FBT (fluid bed technology) epoxy coating and stainless steel, the valve reduces head loss, throttling noise and cavitation damage. An orifice plate assembly, needed for the proper functioning, is supplied with the valve.

### Applications

- On the outlet supply of storage tanks or downstream booster pump stations to control the maximum flow and limit the level within the required values.
- On the rooftop reservoirs as hydraulic back up for level control to avoid overflow.
- On the inlet supply line of storage tanks to control the level and avoid excess in flow during opening.

### Accessories

- Linear position transmitter with 4-20 mA output Mod. PF CSPL.
- On-off position transmitter Mod. PF CSPO.
- Pressure measurement kit.
- Self-flushing and high capacity filter.

### Note to the engineer

- PF anti-cavitation low flow stability plugs are recommended to provide an accurate regulation in case of low flow conditions.
- For the best accuracy leave 5 DN between the valve and the orifice plate and 3 DN downstream of it.

### Additional features

- H-VAL 334/434-FR minimum and maximum flow level control valve with back flow prevention system.
- H-VAL 334/434-5 minimum and maximum level control valve with solenoid.

### Working conditions

- Fluid: treated water.
- Minimum operating pressure: 1,2 bar.
- Maximum operating pressure: 16 bar.
- Recommended working pressure: 6 bar. Higher on request.
- Maximum temperature: 70°C.

### Flow rate control pilot adjustment range

- The orifice plate assembly is calculated and machined according to the maximum flow rate. An adjustment range of the value is possible according to the regulation flow chart supplied with the valve.

### Min.-max. level control pilot adjustment range

- Between 0,2 and 4 meters.

## Operating principle

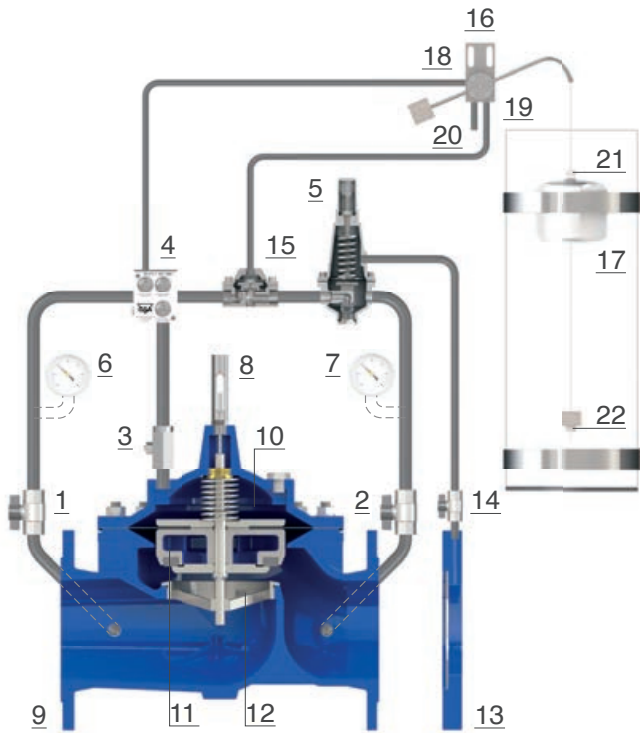

The PF model H-VAL 334/434 is operated by a 2 ways pilot (5) for flow control and connected to the orifice plate assembly (13), with pre-set set and adjustable values, sensing the differential pressure created by the flow rate. The three ways minimum and maximum level pilot Rotoway (16) receives the upstream pressure from the G.R.I.F.O. (4) and, by means of the hydraulic flow accelerator (15), will interrupt the flow to the circuit diverting all pressure to the main chamber (10) when the water level has reached the maximum value. Should the latter drop below the minimum set-point, both values adjustable through mechanical blocks sliding on the wire, pressure is relieved out of the chamber of the flow accelerator (15) through the three ways pilot drain (20). Consequently the pressure of the control chamber (10) will be diverted downstream pushing the obturator upwards to generate flow through the main valve (9), enabling the flow rate control function of the pilot (5), whose spring is set to balance for the differential pressure created by the orifice assembly (13).

## Installation layout

In the installation lay-out the PF H-VAL 334/434, flow regulation valve with minimum and maximum level control, is used on an external stilling tank (2). The flange orifice (5), calculated and machined according to the project's requirements, is connected to the valve's pilot (6). The sectioning devices (1) and by-pass, where PF direct acting pressure sustaining valves Model WR/AM (4) are advised, are very important for maintenance operations, as well as the filter (3) to prevent dirt from reaching the control valve.





## Flow automatic control valve with solenoid control

### Mod. H-VAL 335/435

The PF Model XLC 335/435 is a globe pattern hydraulically operated automatic control valve that, working in combination with an orifice plate assembly, limits the maximum flow to a maximum pre-set value, adjustable and regardless of pressure variations. In case of flow rate lower than the required set point the valve will be fully opened. The circuit is also equipped with a solenoid and flow accelerator to enable on-off control in response to signals. Entirely made in ductile cast iron with FBT (fluid bed technology) epoxy coating and stainless steel, the valve reduces head loss, throttling noise and cavitation damages.

#### Applications

- Downstream of pumps to prevent overload and for cavitation protection with on-off control in case of alarms and emergencies.
- On the inlet supply lines of tanks to prevent excessive flow with the possibility of electric float back up.
- In main transmission lines and water distribution systems to equalize operating supply hours between valves and limit the flow for various regimes.

#### Accessories

- Linear position transmitter with 4-20 mA output Mod. PF CSPL.
- On-off position transmitter Mod. PF CSPO.
- Pressure measurement kit.
- Self-flushing and high capacity filter.

#### Note to the engineer

- Inlet and outlet pressure, flow rate are required for the proper sizing.
- PF anti-cavitation low flow stability plugs are recommended to provide an accurate regulation in case of low flow conditions.
- For the best accuracy leave 5 DN between the valve and the orifice plate and 3 DN downstream of it (picture in the next page).

#### Additional features

- H-VAL 335/435-FR flow regulation with solenoid control valve with back flow prevention system.
- H-VAL 335/435-H flow regulation with solenoid control valve with high sensitivity pilot.

#### Working conditions

- Fluid: treated water.
- Minimum operating pressure: 1,2 bar.
- Max. operating press.: 16 bar. Higher on request.
- Maximum temperature: 70°C.

#### Flow rate control pilot adjustment range

- The orifice plate assembly is calculated and machined according to the maximum flow rate. An adjustment range of the value is possible according to the regulation flow chart supplied with the valve.

#### Solenoid electrical data

- Voltages: 24 V DC, 24 V/50 Hz, 230 V/50 Hz. Other voltages on request.
- Power consumption: inrush AC (VA) 24, hold AC (VA) 17 (8 W), DC hot/cold coil 8/9 W.



## Operating principle

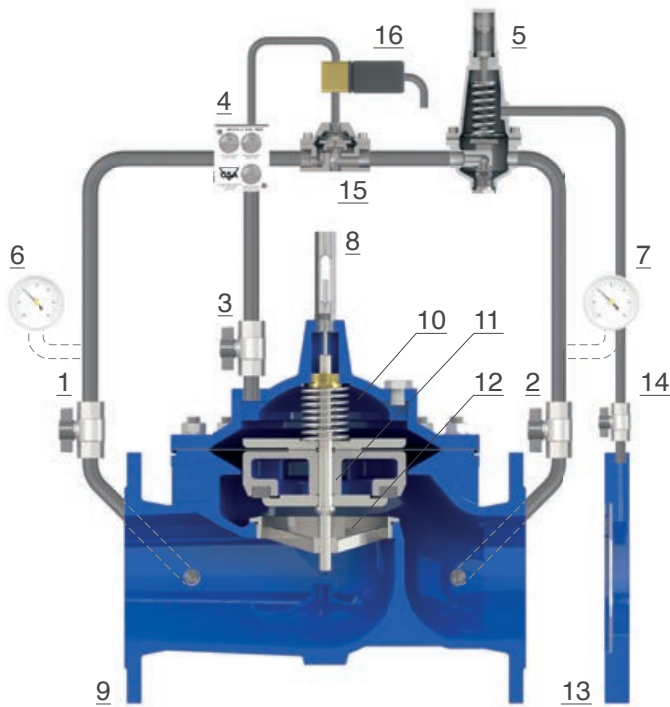

The H-VAL 335/435 is operated by a 2 ways pilot (5), for flow control with pre-set and adjustable values, sensing the drop in pressure produced by the orifice plate (13). Should the flow exceed the maximum value the differential pressure will increase and pilot (5) will throttle and limit the flow, to direct inlet pressure to the main chamber (10) and generate the head loss required through the seat (12) for the valve (9) to control the flow rate. Should the flow remain below the pilot's set-point, the differential pressure across the orifice plate (13) will be less than the pilot's (5) spring force, therefore the valve will remain fully open. A solenoid valve (16) working in combination with a hydraulic accelerator (15) is either interrupting the flow through the circuit pushing the valve (9) to the closed position, or discharging the main chamber (10) to by-pass the flow control pilot (5) and open the main valve (9) completely. Pressure in and out of the main chamber (10) is controlled by the PF exclusive regulation device with filter called GR.I.F.O. (4), needed for the valve's response time and accuracy.

## Installation layout

In the picture the PF H-VAL 335/435 is linked to PF controller (10) or any other electronic device sending impulses according to the function required. The flange orifice (8) is connected to the valve's pilot (9). Sectioning devices (1, 2) and a by-pass with PF pressure control valves (4) are needed for maintenance operations. Anti-surge air valves PF WAVE 3S-AWH (6, 7) are recommended for air release and commissioning, as well as a pressure relief valve PF WR/AM (5) to prevent rise in pressure.

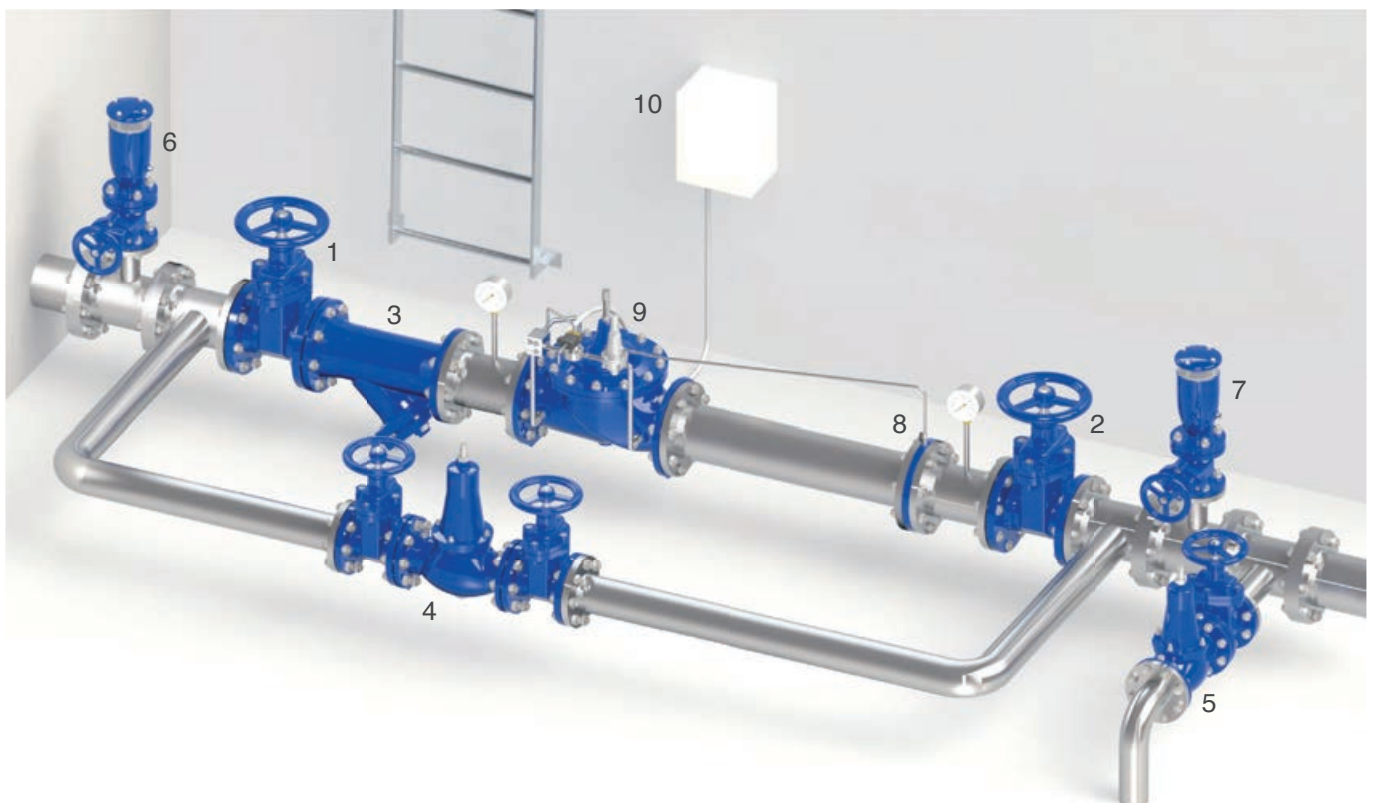



## Burst automatic control valve Mod. H-VAL 380/480

The PF Model H-VAL 380/480 is a globe pattern hydraulically operated automatic control valve that senses the increase in flow above a pre-set and adjustable value of a high sensitivity pilot, diverting the upstream pressure to the main control chamber and causing a complete closure, to be manually reset after that. As long as the flow rate remains below the set point, the valve will be fully open minimizing head loss. Normally equipped with visual position indicator and entirely made in ductile cast iron with FBT (fluid bed technology) coating and stainless steel, the valve is designed to reduce head loss, throttling noise and cavitation damages.

### Applications

- On gravity fed supply lines to avoid depressurization in case of pipe burst due, for example, to landslides.
- On the outlet supply line of storage tanks, water towers to close in case of pipe bursts downstream, preventing level from dropping below a minimum value.
- On water distribution systems and critical supply lines to interrupt flow in case of severe failures like earthquakes, external damages.

### Accessories

- Linear position transmitter with 4-20 mA output Mod. PF CSPL.
- On-off position transmitter Mod. PF CSPO.
- Pressure measurement kit.
- Self-flushing and high capacity filter.

### Note to the engineer

- Inlet pressure, outlet pressure, flow rate and application are required for the proper sizing and cavitation analysis.
- A minimum length of 3 DN downstream and upstream of the valve is recommended for the best accuracy (picture in the next page).

### Additional features

- H-VAL 380/480-FR burst automatic control valve with back-flow prevention.
- H-VAL 380/480-5 burst automatic control valve with solenoid control.

### Working conditions

- Fluid: treated water.
- Minimum operating pressure: 1,5 bar.
- Maximum operating pressure: 16 bar.
- Recommended working pressure: 6 bar. Higher on request.
- Maximum temperature: 70°C.

### Flow rate control pilot adjustment range

- The valve is supplied with the pilot set to the required threshold flow rate, whose adjustment range is available according to the regulation flow chart supplied with the valve.

## Operating principle

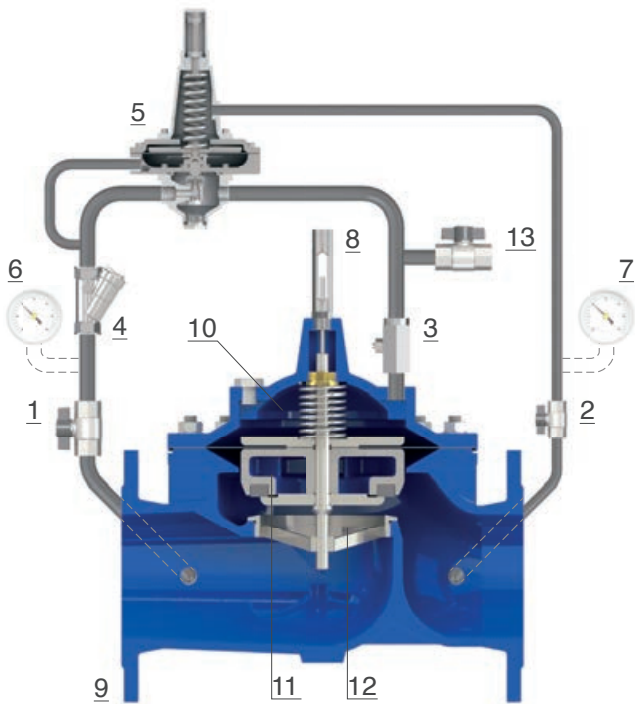

The PF model H-VAL 380/480 is operated by a 2 ways high sensitivity pilot (5), for flow control, with pre-set set and adjustable values, sensing the drop in pressure through the valve produced by the flow rate. Should the latter exceed the maximum value the differential pressure will increase and pilot (5) will open, putting the upstream pressure in communication with the main chamber (10) and closing the main valve (9). Should the flow remain below the pilot's set-point the valve will remain fully open. Once it has been closed the valve needs to be open manually through the isolation ball valve (13) discharging the main chamber (10). Pressure in and out of the main chamber (10) is controlled by the PF needle valve (3) for a smooth regulation, while a filter (4) will prevent debris and dirt from entering the hydraulic circuit with the risk of clogging and possible malfunctioning.

## Installation layout

The PF valve H-VAL 380/480 may cause pressure surge upon closure depending on the location, fluid velocity, differential pressure. A pressure relief valve installed upstream, PF WR/AM or fast acting PF WR/AM (5), is therefore recommended, along with a pressure sustaining valve H-VAL 420 (4) or WR/AM on the by-pass line for the maintenance operations. Anti-surge combination air valves WAVE 3S-AWH (6, 7) are also needed for air control and water hammer protection during commissioning and pipe filling.

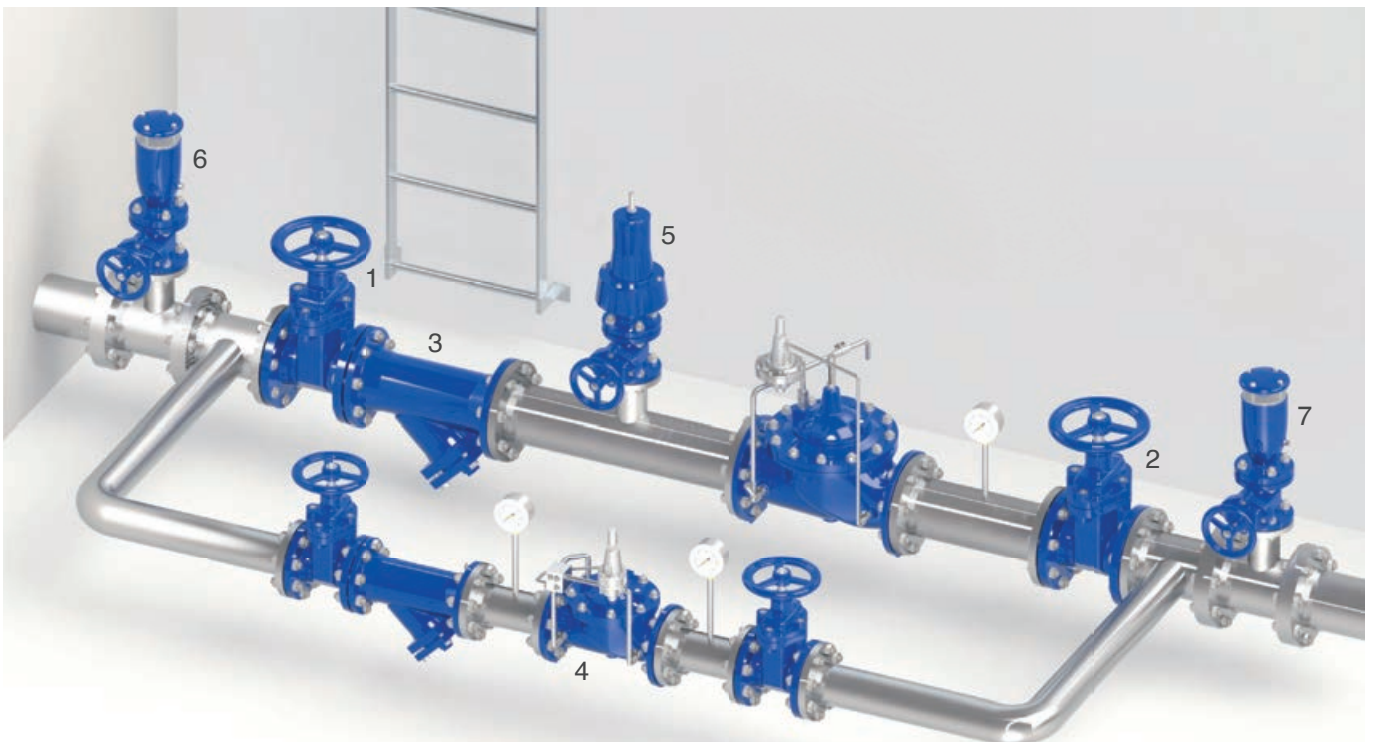





## Minimum-maximum level automatic control valve

### Mod. H-VAL 340/440

The PF Model H-VAL 340/440 is a globe pattern hydraulically operated automatic control valve that regulates the minimum-maximum level of a tank, with an adjustable range, regardless of upstream pressure variations. Thanks to a PF needle valve the response time can be regulated, to prevent water hammer effects during the closing phase. Normally equipped with visual position indicator and entirely made in ductile cast iron with FBT epoxy coating and stainless steel, the valve is designed to reduce head loss, throttling noise and cavitation damage.

#### Applications

- On storage tank to perform a minimum and maximum control, decreasing the operating cycles and therefore maintenance, using at the same time most of the storage capacity.
- For level control with an external container should the main tank not be accessible.
- On rooftop and elevated reservoir in general where level control is maintained through pumps operations, and an hydraulic backup is needed to avoid overflow.

#### Accessories

- On-off position transmitter Mod. PF CSPO.
- Pressure measurement kit.
- Self-flushing and high capacity filter.
- PF anti-cavitation low flow stability plugs are recommended to provide an accurate regulation in case of low flow conditions.
- CSFL mechanical flow regulator.

#### Note to the engineer

- Avoid bends and high points on the piping to connect the main valve to the level control pilot to prevent the formation of air pockets.
- A minimum of 0,6 bar on the pilot is needed, failing in doing so would create delays and malfunctioning. Consider the use of a sustaining pilot for low pressure conditions and/or the CSFL mechanical flow regulator.

#### Additional features

- H-VAL 340/440-FR minimum maximum level control with back-flow prevention.
- H-VAL 445 minimum maximum level control with solenoid control.
- H-VAL 340/440-R minimum maximum level control with surge prevention pilot.

#### Working conditions

- Fluid: treated water.
- Minimum operating pressure: 0,6 bar on the pilot.
- Maximum operating pressure: 16 bar.
- Recommended working pressure: 6 bar. Higher on request.
- Maximum temperature: 70°C.

#### Min.-max. level control pilot adjustment range

- Between 0,2 and 4 meters.

## Operating principle (for DN 150-600)

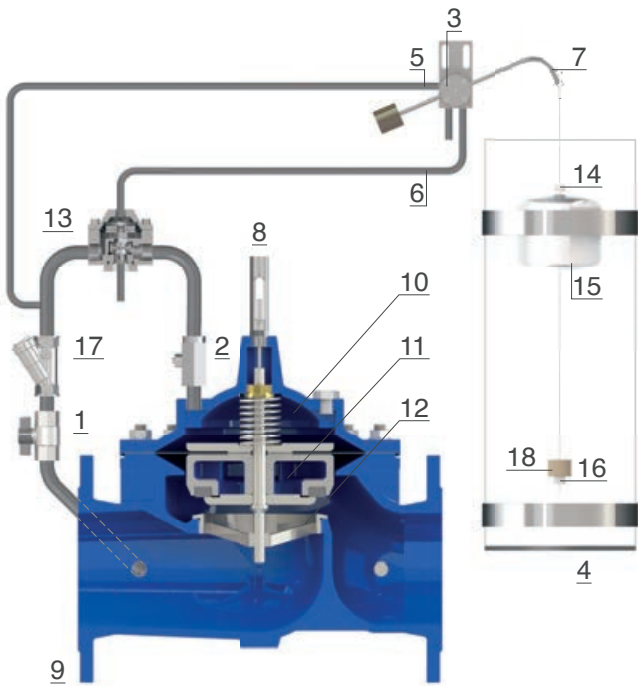

The PF valve model H-VAL 340/440 is operated by a 3 ways pilot connected to the valve by means of two pipes, not supplied. The level control pilot, entirely made in stainless steel, is composed of a body (3), lever (7), float (15) and wire, and contains two mechanical blocks adjustable and set to the required level (14 and 16). Should the latter reach the maximum level the float (15) moves the upper block (14) upwards, to rotate the lever (7) thus allowing the closing of the valve by putting the upstream pressure in communication with the chamber of the valve (10) or the hydraulic accelerator (13) (available from DN 150 and above). The valve remains closed until the level drops to the lower set point (16) which enables the rotation of the lever (7) putting the chamber (10 or 13) in communication with the atmosphere, thus raising the obturator (11) to generate flow through the seat (12). A needle valve on the chamber (2) will control pressure and flow in and out to prevent surges during closure.

## Installation layout

The picture shows the layout of the H-VAL 340/440 minimum-maximum level control valve. The connection between the valve and the pilot (4) is obtained by means of two pipes, one linked to the upstream pressure and the other to the chamber. Sectioning devices (1) and filter (3) are needed for maintenance operations and to prevent dirt from entering the main valve. The external stilling container (2), strongly advised, allows for the proper control reducing turbulence of the water surface without having to access the tank.





## Constant level automatic control valve Mod. H-VAL 360/460-MCP

The PF Model H-VAL 360/460-MCP is a globe pattern hydraulically operated automatic control valve that regulates the constant level of a tank, regardless of upstream pressure variations, by means of a stainless steel proportional flow modulating pilot. Thanks to a needle valve on the chamber the response time can be adjusted, to prevent water hammer effects during the closing phase. Normally equipped with visual position indicator and entirely made in ductile cast iron with FBT epoxy coating and stainless steel, the valve is designed to reduce head loss, throttling noise and cavitation damage.

### Applications

- For break pressure tanks and when a proportional level control is needed within the pilot's range.
- For level control on gravity fed pipelines.
- For small tank and in need of maintaining a constant level with a continuous modulating.

### Accessories

- On-off position transmitter Mod. PF CSPO.
- Pressure measurement kit.
- Self-flushing and high capacity filter.
- PF anti-cavitation low flow stability plugs are recommended to provide an accurate regulation in case of low flow conditions.
- CSFL mechanical flow regulator.

### Note to the engineer

- Avoid bends and high points on the piping to connect the main valve to the level control pilot to prevent the formation of air pockets.
- For the proper functioning a minimum of 0,6 bar on the pilot is needed, failing in doing so would create delays and malfunctioning. Consider the use of a sustaining pilot for low pressure conditions and/or the PF CSFL mechanical flow regulator.

### Additional features

- H-VAL 360/460-MCP-FR constant level control valve with back-flow prevention.
- H-VAL 360/460-MCP-R constant level control valve with surge prevention pilot.

### Working conditions

- Fluid: treated water.
- Minimum operating pressure: 0,6 bar on the pilot.
- Maximum operating pressure: 16 bar.
- Recommended working pressure: 6 bar. Higher on request.
- Maximum temperature: 70°C.

### Constant level pilot adjustment range

- 85 mm as a standard, different on request.



## Operating principle

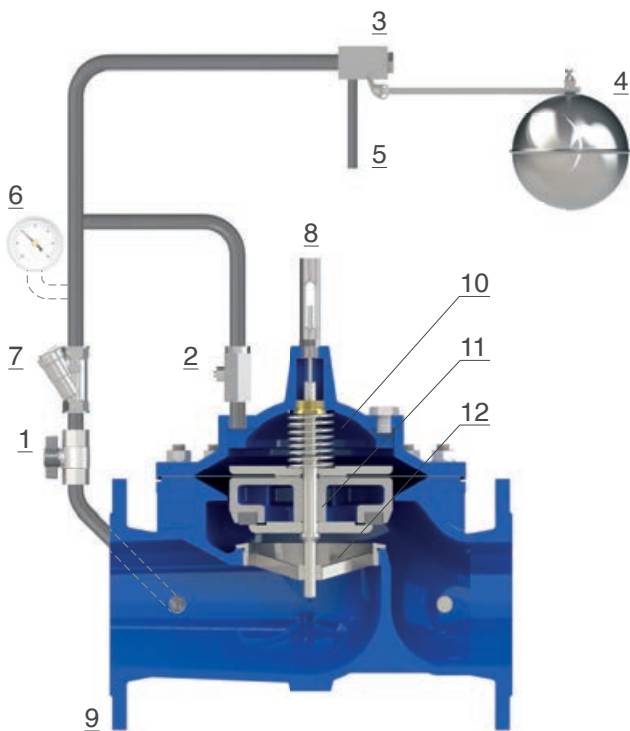

The PF model H-VAL 360/460-MCP is operated by a 2 ways flow modulating proportional pilot (3) entirely made in stainless steel and connected to the valve by means of a pipe, not supplied. Should the level inside the tank drop due to consumption the pilot (3) will open through the drain (5) discharging the main chamber (10), and generating a passage through the seat (12) in proportion to the demand, lifting the obturator (11) upwards accordingly. Should the tank level rise due to the refilling the pilot (3) will modulate, throttling the flow through the drain (5) and, if required, closing the valve by putting the upstream pressure in communication with the main chamber (10). A needle valve (13) on the chamber (10) will control pressure and flow in and out to prevent surges during closure.

## Installation layout

The H-VAL 360/460-MCP is linked to the pilot (2) through a single pipe. Sectioning devices (1) are recommended for maintenance and a filter (3) is needed upstream, to prevent dirt from entering the main valve, affecting the performance. The constant level control pilot (2) should always be located in a position away from the water surface turbulence created by the inlet supply pipe to the tank. In case of static values higher than 6 bar the AC (anti-cavitation) system and a PF pressure reducer WR/AM are advised.





## Constant level automatic control valve **H-VAL 360/460 - Rotoway**

The PF Model H-VAL 360/460-Rotoway is a globe pattern hydraulically operated automatic control valve that regulates the constant level of a tank, by means of a three ways pilot in stainless steel, regardless of upstream pressure variations. Thanks to a PF needle valve the response time can be adjusted, to prevent water hammer effects during the closing phase. Normally equipped with visual position indicator, and entirely made in ductile cast iron with FBT epoxy coating and stainless steel, the valve is designed to reduce head loss, throttling noise and cavitation damage.

### Applications

- For break pressure tanks, when a constant level control is needed and a stainless steel pilot is required.
- For level control on gravity fed pipelines.
- For small tank in need of maintaining a constant level with on/off regulation.

### Accessories

- On-off position transmitter Mod. PF CSPO.
- Pressure measurement kit.
- Self-flushing and high capacity filter.
- AC anti-cavitation trim to provide a higher resistance to cavitation and accurate regulation in case of low flow.
- CSFL mechanical flow regulator.

### Note to the engineer

- Avoid bends and high points on the piping to connect the main valve with the level control pilot to prevent the formation of air pockets.
- For the proper functioning a minimum of 0,6 bar on the pilot is needed, failing in doing so would create delays and malfunctioning. Consider the use of a sustaining pilot for low pressure conditions and/or the PF CSFL mechanical flow regulator.

### Additional features

- H-VAL 360/460-Rotoway-FR constant level control valve with back-flow prevention.
- H-VAL 360/460-Rotoway-R constant level control valve with surge prevention pilot.

### Working conditions

- Fluid: treated water.
- Minimum operating pressure: 0,6 bar on the pilot.
- Maximum operating pressure: 16 bar.
- Recommended working pressure: 6 bar. Higher on request.
- Maximum temperature: 70°C.

### Constant level pilot adjustment range

- 360 mm as standard, different on request by changing the lever.

## Operating principle (for DN 150-600)

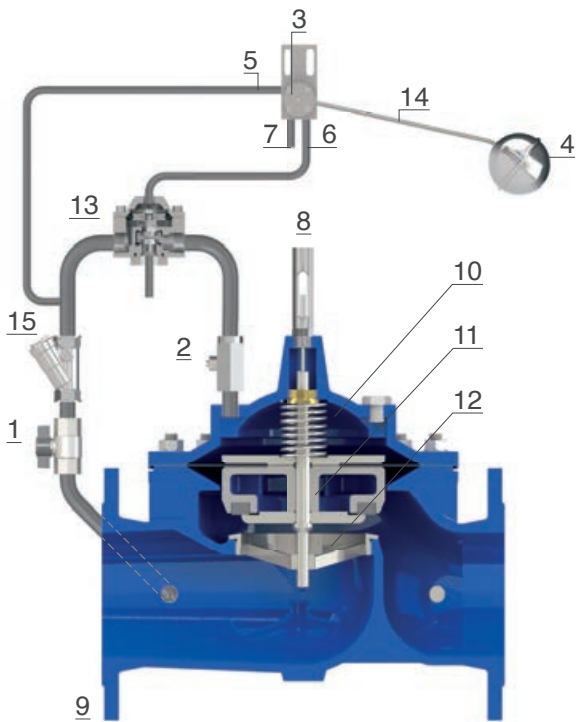

PF model H-VAL 360/460-Rotaway is operated by a 3 ways pilot connected to the valve by means of two pipes, not supplied. The pilot assembly, entirely made in stainless steel, is composed of a body (3), float (4) sensing the water level variation and a lever (14) which can be adapted according to the project requirements. Should the water level reach the maximum threshold the float (4) moves upwards, rotating the lever (14) thus allowing the closing of the valve by putting the upstream pressure in communication with the chamber (10) of the valve or the hydraulic accelerator (13) (available from DN 150 and above). The valve remains closed until the level drops to the lowest set point (16), which enables the rotation of the lever (14) putting the chamber (10) in communication with the atmosphere, thus raising the obturator (11) to generate flow through the seat (12). The exclusive PF needle valve on the chamber (2) will control pressure and flow in and out to prevent surges during closure.

## Installation layout

In the installation layout the H-VAL 360/460 Rotaway is linked to the pilot (2) through two pipes. The filter (3) is needed upstream to prevent dirt and sectioning devices (1) are mandatory to perform maintenance operations. The constant level control pilot (2) should always be located in a position away from the water surface turbulence created by the inlet supply pipe to the tank. In case of static values higher than 6 bar the AC (anti-cavitation) system and a PF pressure reducer WR/AM are advised.







## Constant level control valve with on-off solenoid control Mod. H-VAL 365/465-MCP

The PF Model H-VAL 365/465-MCP maintains the constant level of a tank, regardless of upstream pressure variations, by means of a flow modulating proportional pilot in stainless steel.

The circuit is also equipped with a solenoid to enable an on-off control mode in response to signals from remote or by a controller. Thanks to a PF needle valve the response time can be adjusted, to prevent water hammer effects during the closing phase. Normally equipped with visual position indicator, and entirely made in ductile cast iron with FBT epoxy coating and stainless steel, the valve is designed to reduce head loss, throttling noise and cavitation damage.

### Applications

- For break pressure tanks with a proportional level control and emergency electronic backup, to prevent overflow.
- For level control on gravity fed pipelines with on/off mode operated from remote or alarms.

### Accessories

- On-off position transmitter Mod. PF CSPO.
- Pressure measurement kit.
- Self-flushing and high capacity filter.
- AC anti-cavitation trim to provide a higher resistance to cavitation and accurate regulation in case of low flow.
- CSFL mechanical flow regulator.

### Note to the engineer

- Avoid bends and high points on the piping to connect the main valve with the level control pilot to prevent the formation of air pockets.
- For the proper functioning a minimum of 0,6 bar on the pilot is needed, failing in doing so would create delays and malfunctioning. Consider the use of a sustaining pilot for low pressure conditions and/or the PF CSFL mechanical flow regulator.

### Additional features

- H-VAL 365/465-MCP-FR constant level valve with solenoid control and back-flow prevention.
- H-VAL 365/465-MCP-R constant level valve with solenoid control and surge prevention pilot.

### Working conditions

- Fluid: treated water.
- Minimum operating pressure: 0,6 bar on the pilot.
- Maximum operating pressure: 16 bar.
- Recommended working pressure: 6 bar. Higher on request.
- Maximum temperature: 70°C.

### Constant level pilot adjustment range

- 85 mm as a standard, different on request.

### Solenoid electrical data

- Voltages: 24 V DC, 24 V/50 Hz, 230 V/50 Hz. Other voltages on request.
- Power consumption: inrush AC (VA) 24, hold AC (VA) 17 (8 W), DC hot/cold coil 8/9 W.

## Operating principle

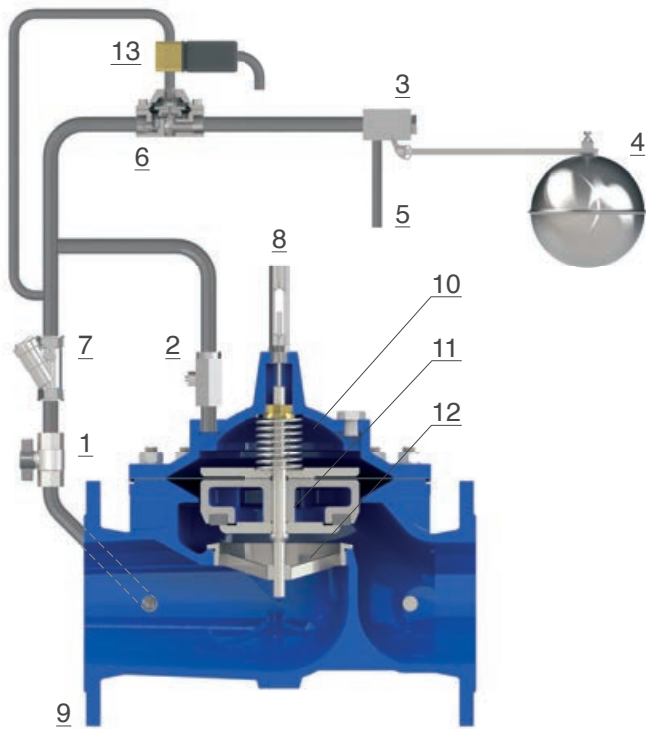

The H-VAL 365/465-MCP is operated by a 2 ways flow modulating proportional pilot (3) in stainless steel connected to the valve by means of a pipe, not supplied. Should the level inside the tank drop due to consumption the pilot (3) will open the drain (5) discharging the main chamber (10) to generate a passage through the seat (12), in proportion to the demand, lifting the obturator (11) upwards. Should the tank level rise due to the refilling the pilot (3) will modulate, throttling the flow through the drain (5) and, if required, closing the valve by putting the upstream pressure in communication with the chamber (10). In case of signals sent to the solenoid valve (13) the flow through the hydraulic accelerator (6) will be interrupted, therefore diverting the upstream pressure to the main chamber (10) and closing the main valve (9).

A fixed orifice is present on the filter (7) for the proper functioning, while a needle valve (2) on the chamber (10) will control pressure and flow in and out to prevent surges during closure.

## Installation layout

The H-VAL 365/465-MCP is linked to the pilot (2) through a single pipe and operated by signals sent by a PF controller or from remote. Sectioning devices (1) are recommended for maintenance and a filter (3) is needed upstream, to prevent dirt from entering the main valve. The level pilot (2) should always be located in a position away from the turbulence created by the inlet supply pipe to the tank. In case of static values higher than 6 bar the AC (anti-cavitation) system and a PF pressure reducer W-VAL HP are advised.





## High sensitivity altitude automatic control valve Mod. H-VAL 370/470

The PF Model H-VAL 370/470 is a globe pattern hydraulically operated automatic valve that maintains the constant level of a reservoir and water tower, regardless of upstream pressure variations. The modulating control ensures a smooth regulation and absence of water hammer, as the valve will react proportionally to the variations in demand. Normally equipped with visual position indicator, and entirely made in ductile cast iron with FBT epoxy coating and stainless steel, the valve is designed to reduce head loss, throttling noise and cavitation damage.

### Applications

- To perform the level control of elevated tanks and water towers.
- Through the high sensitivity pilot to control the water level, without accessing the tank and the need of any piping and pilots.
- On the tank and reservoirs outlet supply lines to control the consumption by means of the storage static pressure.

### Accessories

- Linear position transmitter with 4-20 mA output Mod. PF CSPL.
- On-off position transmitter Mod. PF CSPO.
- Pressure measurement kit.
- Self-flushing and high capacity filter.

### Note to the engineer

- Inlet pressure, outlet pressure, flow rate and application are required for the proper sizing and cavitation analysis.
- For the proper functioning a minimum of 0,25 bar static value acting on the pilot is needed. Consider the use of a sustaining pilot for low pressure conditions and/or the PF CSFL mechanical flow regulator.

### Additional features

- H-VAL 370/470-FR altitude automatic control valve with back-flow prevention.
- H-VAL 427 upstream pressure sustaining and altitude control valve.
- H-VAL 427-5 altitude automatic control valve with on-off solenoid control.
- The valve can be supplied without the regulation device GR.I.F.O. on request.

### Working conditions

- Fluid: treated water.
- Min. operating pressure on the valve: 0,7 bar.
- Minimum static pressure on the pilot: 0,25 bar.
- Max. operating press.: 16 bar.
- Recommended working pressure: 6 bar. Higher on request.
- Maximum temperature: 70°C.

### Altitude pilot adjustment range

- Blue spring: 0,3 to 1,8 bar.
- Red spring: 0,6 to 2,8 bar.
- Different values on request.



## Operating principle

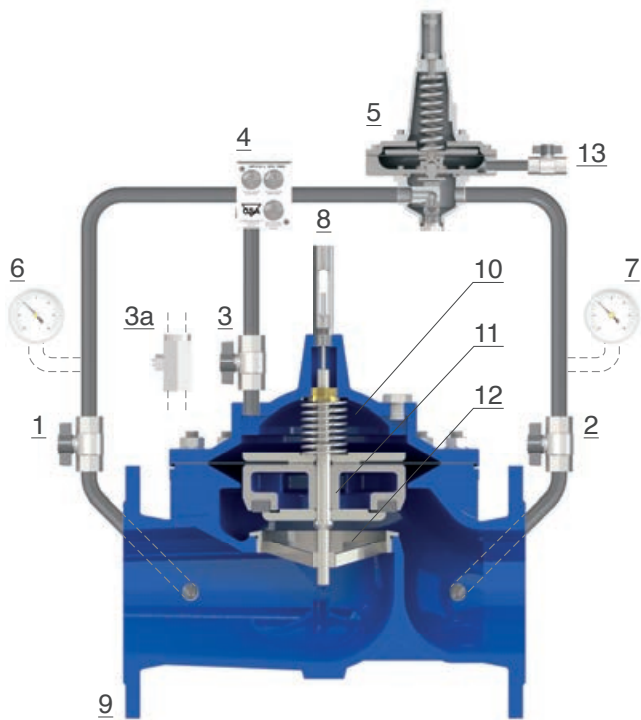

The PF Model H-VAL 370/470 is operated by a 2 ways high sensitivity pilot (5) sensing the static pressure of the level in need of regulation through the port (13). Should the latter drop due to consumption, the pilot (5) will open proportionally, relieving pressure out of the main chamber (10) thus lifting the obturator upwards (11) to generate flow through the seat and refill the storage. When the water level rises the pilot (5) will modulate throttling the flow through the circuit and diverting pressure back to the chamber (10), pushing the obturator downwards, and eventually closing the valve once the level has reached maximum set-point. Pressure in and out of the main chamber (10) is controlled by the PF exclusive regulation device with filter called GR.I.F.O. (4), needed for the valve's response time and accuracy.

## Installation layout

Level control is obtained without any external piping and simply through a pilot sensing the static pressure coming from the water tower. The lay-out includes sectioning devices (1, 2) and by-pass, where PF automatic control valves (4) are advised, for maintenance operations, and a filter (3) to prevent dirt from entering the main valve. Anti-surge combination air valves WAVE 3S-AWH (5) are recommended upstream to release air pockets accumulated in working conditions, and to discharge large volumes of air during filling.

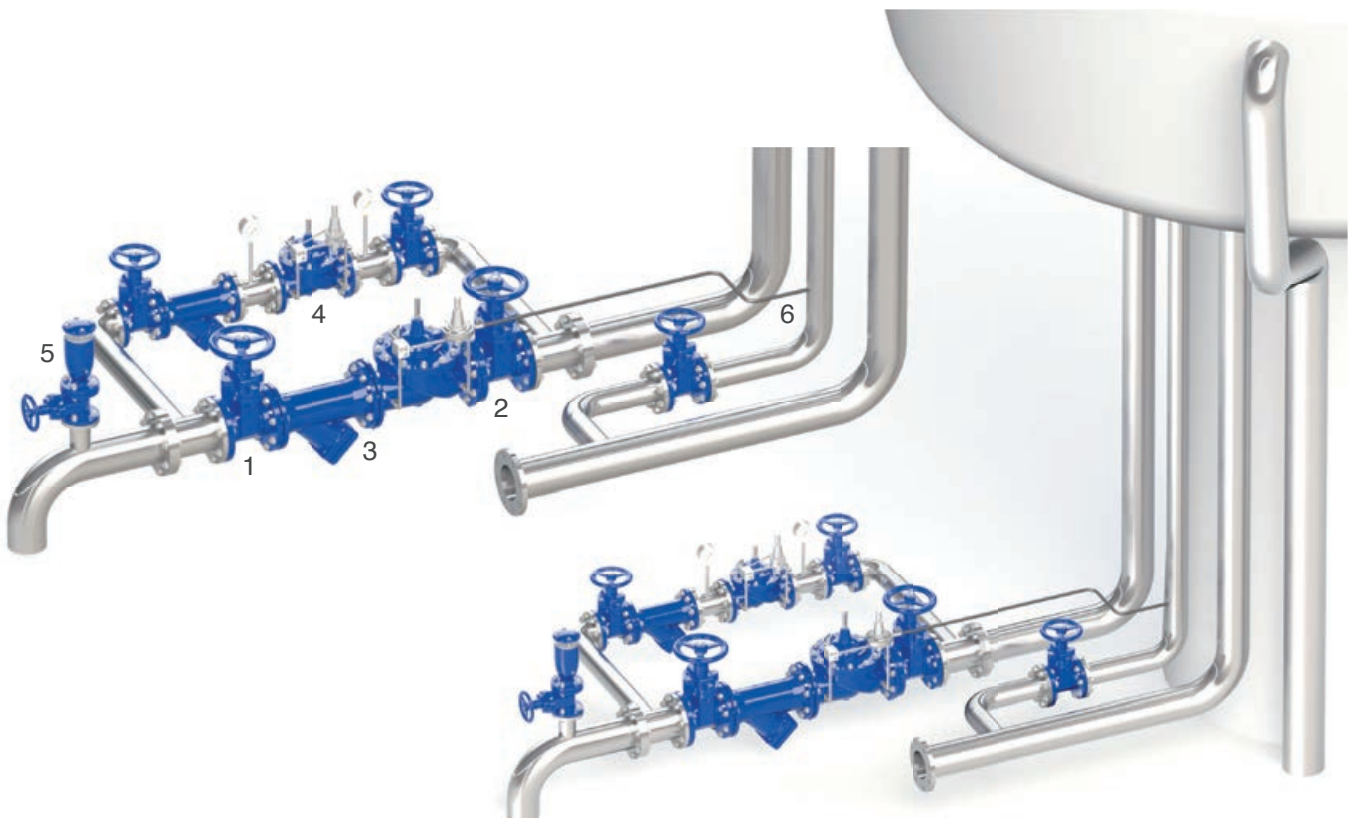



## High sensitivity altitude control valve with two set points **Mod. H-VAL 370/470-D**

The PF Model H-VAL 370/470-D is a globe pattern hydraulically operated automatic valve that regulates the water level of a reservoir and water tower within a minimum and maximum value, regardless of upstream pressure variations. The modulating control ensures a smooth regulation and absence of water hammer. Normally equipped with visual position indicator, and entirely made in ductile cast iron with FBT epoxy coating and stainless steel, the valve is designed to reduce head loss, throttling noise and cavitation damage.

### Applications

- To perform the level control of elevated tanks and water towers with a minimum and maximum range.
- Through the high sensitivity pilot to control the water level, without accessing the tank and the need of any extra piping.
- On the tank and reservoirs outlet supply lines to control the consumption by means of the storage static pressure working on a specific range pre-set and adjustable through the minimum and maximum pilots.

### Accessories

- Linear position transmitter with 4-20 mA output Mod. PF CSPL.
- On-off position transmitter Mod. PF CSPO.
- Pressure measurement kit.
- Self-flushing and high capacity filter.

### Note to the engineer

- Inlet pressure, outlet pressure, flow rate and application are required for the proper sizing.
- For the proper functioning a minimum of 0,3 bar static value acting on the pilot is needed. Consider the use of a sustaining pilot for low pressure conditions and/or the PF CSFL mechanical flow regulator.

### Additional features

- H-VAL 370/470-FR altitude automatic control valve with back-flow prevention.
- H-VAL 427 upstream pressure sustaining and altitude control valve.
- H-VAL 427-5 altitude automatic control valve with on-off solenoid control.
- The valve can be supplied without the regulation device GR.I.F.O. on request.

### Working conditions

- Fluid: treated water.
- Min. operating pressure on the valve: 0,7 bar.
- Minimum static pressure on the pilot: 0,3 bar.
- Max. operating press.: 16 bar.
- Recommended working pressure: 6 bar. Higher on request.
- Maximum temperature: 70°C.

### Altitude pilot adjustment range

- Blue spring: 0,3 to 1,8 bar.
- Red spring: 0,6 to 2,8 bar.
- Different values on request.

## Operating principle

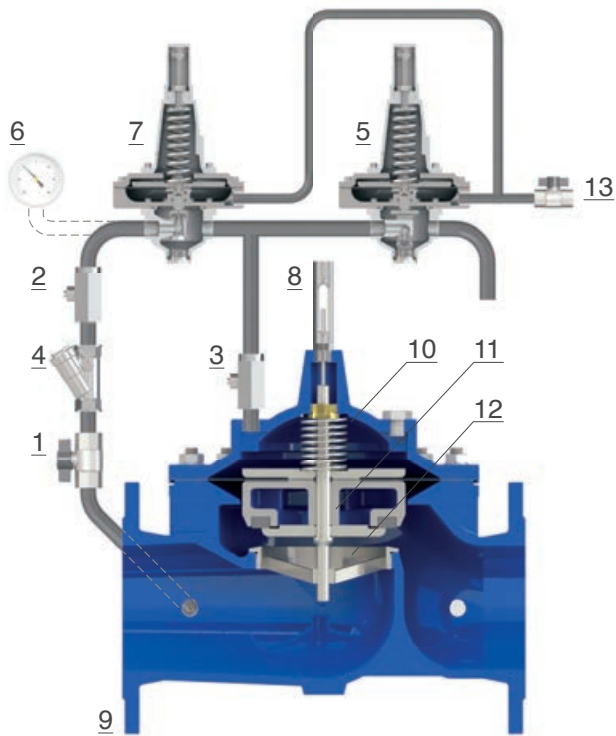

The PF Model H-VAL 370/470-D is operated by two high sensitivity pilots (5 and 7) sensing the static pressure of the level in need of regulation through a port (13). Should the level inside the tank rise above the maximum set point the pilot (7) will open diverting the flow towards the chamber (10) closing the valve. The valve will remain closed until the water level drops, due to consumption, to the minimum value at which the pilot (5) will open, relieving pressure out of the main chamber (10) thus lifting the obturator upwards (11) to generate flow through the seat and refill the storage. Pressure in and out of the main chamber (10) is controlled by the CSA exclusive needle valve (3) to ensure smooth operation and the absence of unwanted pressure surges.

## Installation layout

Level control is obtained without any external piping and simply through a pilot sensing the static pressure coming from the water tower. The lay-out includes sectioning devices (1, 2) and by-pass, where PF automatic control valves (4) are advised, for maintenance operations, and a filter (3) to prevent dirt from entering the main valve. Anti-surge combination air valves WAVE 3S-AWH (5) are recommended upstream to release air pockets accumulated in working conditions, and to discharge large volumes of air during filling.

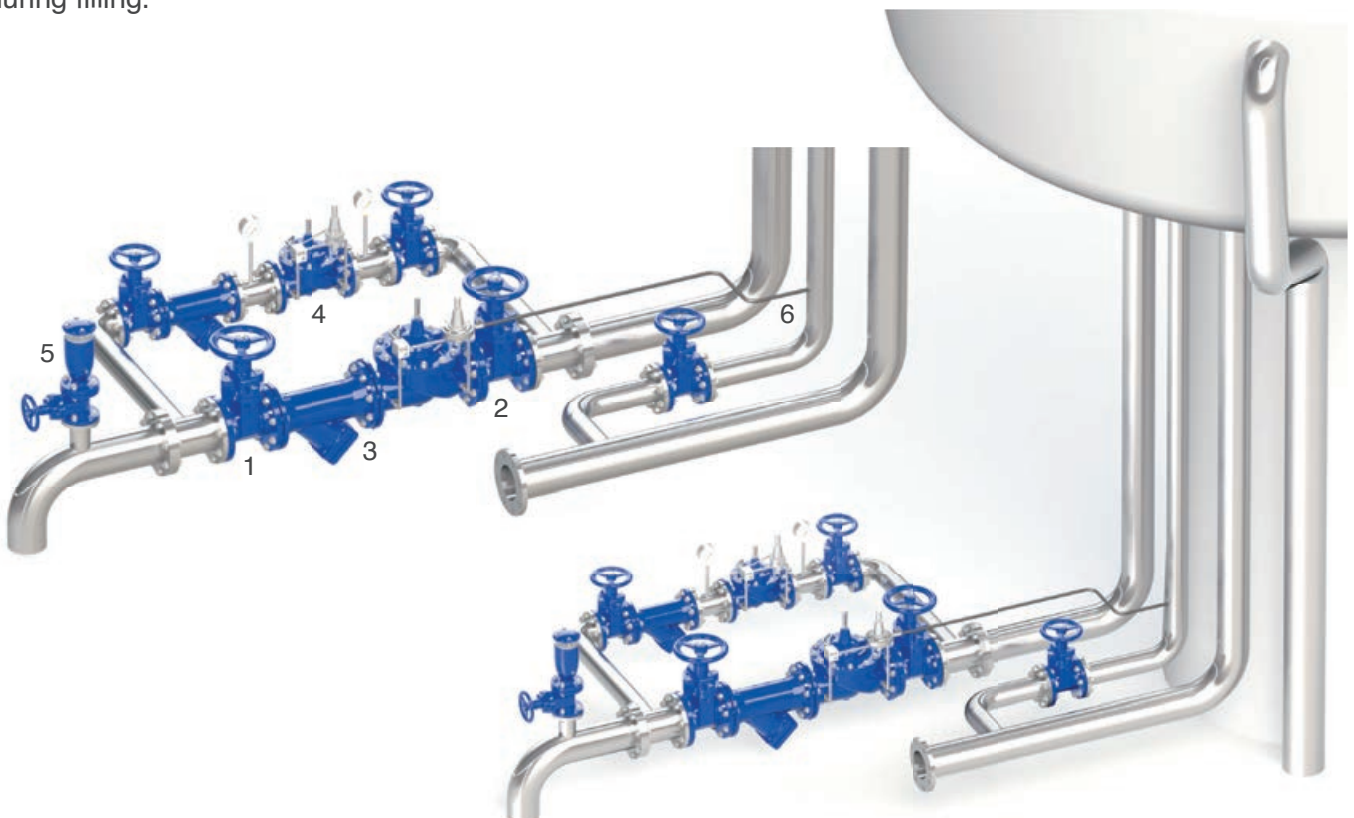





## On-off solenoid automatic control valve Mod. H-VAL 350/450

The PF Model H-VAL 350/450 is a globe pattern hydraulically operated automatic control valve that opens and closes in response to signals applied to the solenoid on the circuit, regardless of upstream pressure variations. Thanks to a PF needle valve located on the chamber the reaction time can be adjusted, to prevent water hammer effects during the closing phase. Normally equipped with visual position indicator and entirely made in ductile cast iron with FBT (fluid bed technology) epoxy coating and stainless steel, the valve is designed to reduce head loss, throttling noise and cavitation damage.

### Applications

- On main supply lines and water distribution networks to interrupt water supply in case of alarms and emergencies.
- In combination with an electric float for tank level regulation and control.
- As a system protection to shut-off in case of burst events.
- In filtration systems for back flushing.
- On storage tanks for automatic refreshing.

### Accessories

- On-off position transmitter Mod. PF CSPO.
- Pressure measurement kit.
- Self-flushing and high capacity filter.
- CSFL mechanical flow regulator.

### Note to the engineer

- Inlet pressure, outlet pressure, flow rate and application are required for the proper sizing and cavitation analysis.
- Recommended flow rate and operating conditions on the H-VAL series engineering.
- PF anti-cavitation low flow stability plugs are recommended to provide an accurate regulation in case of low flow conditions.

### Additional features

- H-VAL 350/450-FR on-off solenoid control valve with back-flow prevention system.
- H-VAL 350/450-R on-off solenoid control valve with surge prevention system.

### Working conditions

- Fluid: treated water.
- Minimum operating pressure: 0,7 bar.
- Maximum operating pressure: 16 bar. Higher on request.
- Maximum temperature: 70°C.

### Solenoid electrical data

- Voltages: 24 V DC, 24 V/50 Hz, 230 V/50 Hz. Other voltages on request.
- Power consumption: inrush AC (VA) 24, hold AC (VA) 17 (8 W), DC hot/cold coil 8/9 W.

## Operating principle (for DN 150-600)

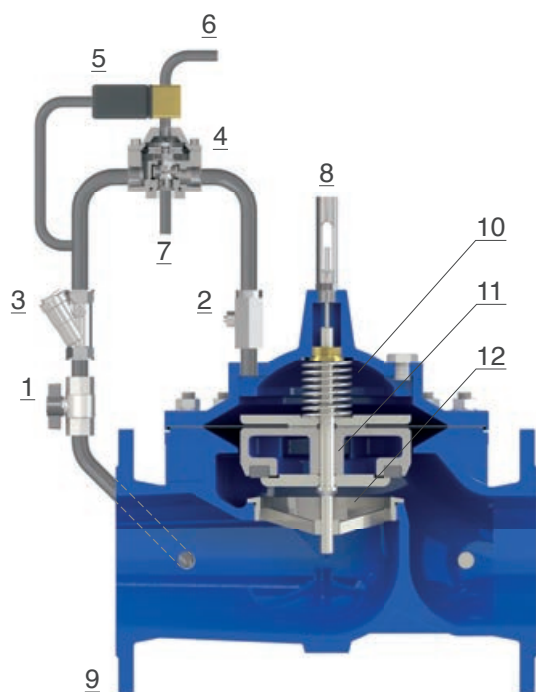

The PF model H-VAL 350/450 is operated by a solenoid (5) working in combination with a flow accelerator or as a standalone unit, receiving impulses by remote or by a PF controller, to perform either a fully closed or open function depending on what the valve is supposed to do in absence of power supply. The hydraulic accelerator (4) is present from DN 150 mm and above. In case of a normally open valve, for example, when the impulse is sent to the solenoid (5), the upstream pressure is diverted into the main chamber (10) directly, or through the hydraulic accelerator (4), pushing the obturator (11) towards the seat (12) then interrupting the supply. Should the signal be removed pressure will be taken out of the main chamber (10) directly or through the hydraulic accelerator (4), to lift the obturator (11) upwards then opening the main valve (9). Pressure in and out of the main chamber (10) is controlled by the PF needle valve (2) needed for the valve's response avoiding possible surges and rapid pressure fluctuations. A filter (3) will protect the solenoid and the rest of the circuit from dirt.

## Installation layout

The picture shows the layout of the PF H-VAL 350/450 linked to a PF controller (4) or any other electronic device sending impulses. In this case an electric float (2) is used for water tank level regulation, according to the function required. Sectioning devices (1) are important for maintenance operations as well as a filter (3) to prevent dirt from entering the valve. Anti-surge combination air valves WAVE 3S-AWH are recommended upstream of the installation for air release during operating conditions and pipe filling.





## On-off solenoid control battery operated flush valve **Mod. H-VAL 350/450-P**

The PF Model H-VAL 350/450-P is a globe pattern hydraulically operated automatic control valve, normally closed, that opens in response to the signals supplied by a battery operated programmer, regardless of upstream pressure variations. The main function is to flush pipelines and/or to create water circulation by using up to three programs per day.

Normally equipped with visual position indicator and entirely made in ductile cast iron with FBT (fluid bed technology) epoxy coating and stainless steel, the valve is designed to reduce head loss, throttling noise and cavitation damage.

### Applications

- In derivation from main supply lines to create water circulation through specific programs where power supply is not available.
- Installed in water distribution networks to flush and clean dead ends and segments with water in stagnant conditions.

### Accessories

- Pressure measurement kit.
- Self-flushing and high capacity filter.
- Box container for submerged application.
- CSFL mechanical flow regulator.

### Note to the engineer

- Inlet pressure, outlet pressure, flow rate and application are required for the proper sizing and cavitation analysis.
- Recommended flow rate and operating conditions on the H-VAL series engineering.
- Oversizing the valve may generate excessive pressure drop during opening, likely to prevent the valve from closing.

### Additional features

- H-VAL 350/450-P-FR on-off solenoid control valve with battery operated programmer and back-flow prevention system.
- H-VAL 350/450-P-R on-off solenoid control valve with battery operated programmer and surge prevention system.

### Working conditions

- Fluid: treated water.
- Minimum operating pressure: 0,7 bar.
- Maximum operating pressure: 16 bar. Higher on request.
- Maximum temperature: 70°C.

### Battery operated programmer

- Make reference to the operating and installation manual provided with the valve.



## Operating principle (for DN 150-600)

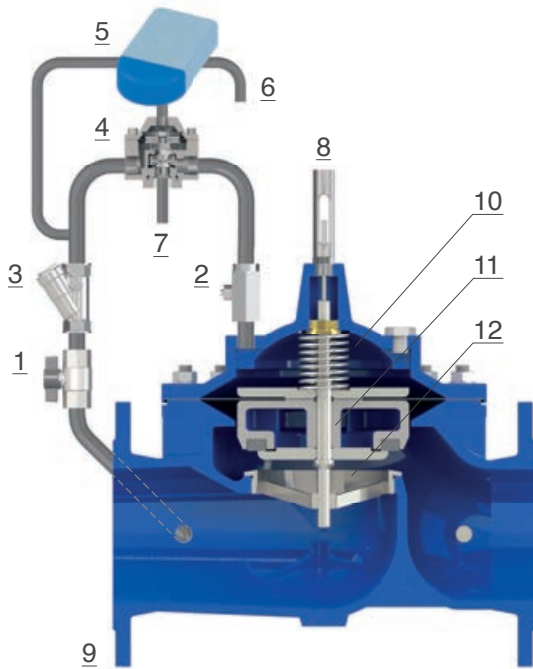

PF model H-VAL 350/450-P is controlled by a battery programmer sending impulses to the solenoid (5), to open the valve accordingly up to three programs per day. When the solenoid is activated by the programmer water is taken out of the main chamber (10) directly or through the accelerator (4), thus pushing the obturator (11) upwards and generating the full flow through the main valve (9). The hydraulic accelerator (4) is present for DN 150 mm and above. When another impulse is triggered by the programmer, at the end of the water supply cycle, pressure is diverted back towards the chamber (10) interrupting the flow.

Pressure in and out of the main chamber (10) is controlled by the PF needle valve (2) needed for the valve's response avoiding possible surges and rapid pressure fluctuations. A filter (3) will protect the solenoid and the rest of components to prevent dirt from entering the mechanical assemblies.

## Installation layout

The picture shows the recommended layout of the PF H-VAL 350/450-P, battery operated solenoid control valve used to flush pipelines, discharging directly into atmosphere or to the drainage system. Sectioning devices (1, 2) are important for maintenance operations as well as a filter (3) to prevent dirt from entering the valve. Anti-surge combination air valves WAVE 3S-AWH (4) are recommended upstream to release air pockets in working conditions, and discharge large volumes of air during pipe filling and commissioning.

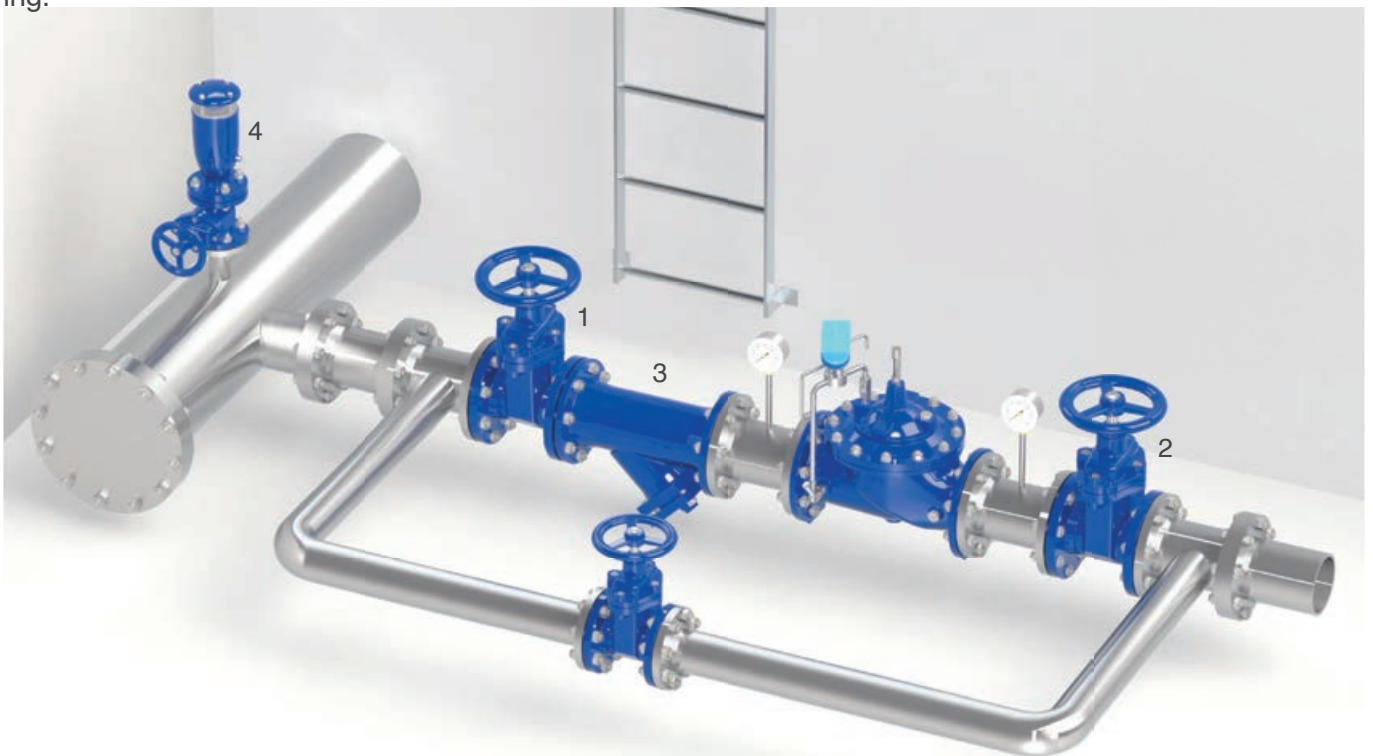



## Step by step solenoid control valve Mod. H-VAL 353/453

The PF Model H-VAL 353/453 is a globe pattern hydraulically operated automatic control valve that modulates in response to signals applied to the solenoids valves. Thanks to PF needle valves located on the circuit the reaction time of the opening and closing can be adjusted, independently one from the other, to ensure a smooth and accurate regulation. A manual emergency circuit is usually supplied with valve in case of power failure. Normally equipped with 4-20 mA position transmitter and made in ductile cast iron with FBT (fluid bed technology) epoxy coating and stainless steel, the valve reduces head loss, throttling noise and cavitation damage.

### Applications

- In combination with PF controllers for pressure management and leakage reduction to regulate pressure versus flow.
- On the inlet supply line of storage tanks to perform level regulation and control.
- On the outlet supply line of storage tanks for flow control as a function of the water level.
- On heating and cooling systems to ensure flow control according to the temperature.

### Accessories

- Linear position transmitter Mod. PF CSPL.
- On-off position transmitter Mod. PF CSPO.
- Pressure measurement kit.
- Self-flushing and high capacity filter.
- CSFL mechanical flow regulator.

### Note to the engineer

- PF anti-cavitation low flow stability plugs are recommended to provide an accurate regulation in case of low flow conditions.
- Recommended flow rate and operating conditions on the H-VAL series engineering.
- The duration of impulses sent to the solenoid is important and changes with valve size and operating pressure.

### Additional features

- H-VAL 353/453-FR step by step solenoid control valve with back-flow prevention system.
- H-VAL 353/453-5 step by step solenoid valve with emergency opening system from remote.
- H-VAL 353/453-R step by step solenoid control valve with surge control system.

### Working conditions

- Fluid: treated water.
- Minimum operating pressure: 1,5 bar.
- Maximum operating pressure: 16 bar. Higher on request.
- Maximum temperature: 70°C.

### Solenoid electrical data

- Voltages: 24 V DC, 24 V/50 Hz, 230 V/50 Hz. Other voltages on request.
- Power consumption: inrush AC (VA) 24, hold AC (VA) 17 (8 W), DC hot/cold coil 8/9 W.

## Operating principle

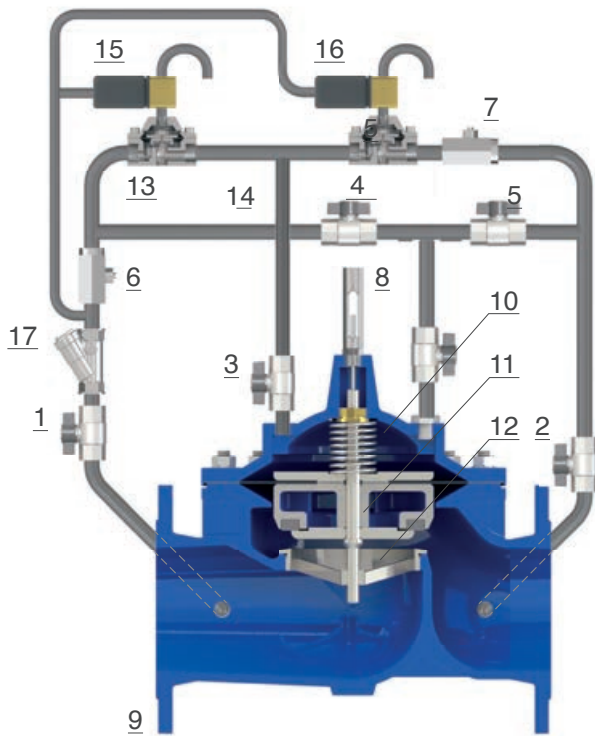

The model H-VAL 353/453 includes two solenoids (15-16) receiving impulses and acting on hydraulic accelerators (13-14), normally closed. Should a signal be sent to the upstream solenoid (15), the latter will allow some flow through (13) and towards the main chamber (10), in proportion to the numbers and duration of such impulses and controlled by the needle valve 6, throttling the passage between obturator (11) and seat (12). In the same way by using the downstream solenoid (16) water will be taken out of the main chamber, with flow and the opening speed controlled by the needle valve (7).

The main valve will therefore modulate in response to the signals sent to both solenoids.

The manual circuit (4-5) is always supplied, unless otherwise stated, and necessary to regulate the valve in case of power failure. A filter (3) will protect the solenoid and the rest of components to prevent dirt from entering the mechanical assemblies.

## Installation layout

In the picture the H-VAL 353/453 is installed in combination with a flow meter (5). A PF controller (8) or other PLC units will constantly send impulses to the valve's solenoids to maintain the same flow regardless of pressure variations, or to manage the pressure according to variations in demand to reduce water loss and leakage. Sectioning devices (1, 2) and a by-pass, with PF direct acting valves (4), are important for maintenance as well as a filter (3) and anti-surge air valves WAVE 3S-AWH (6, 7) upstream and downstream.

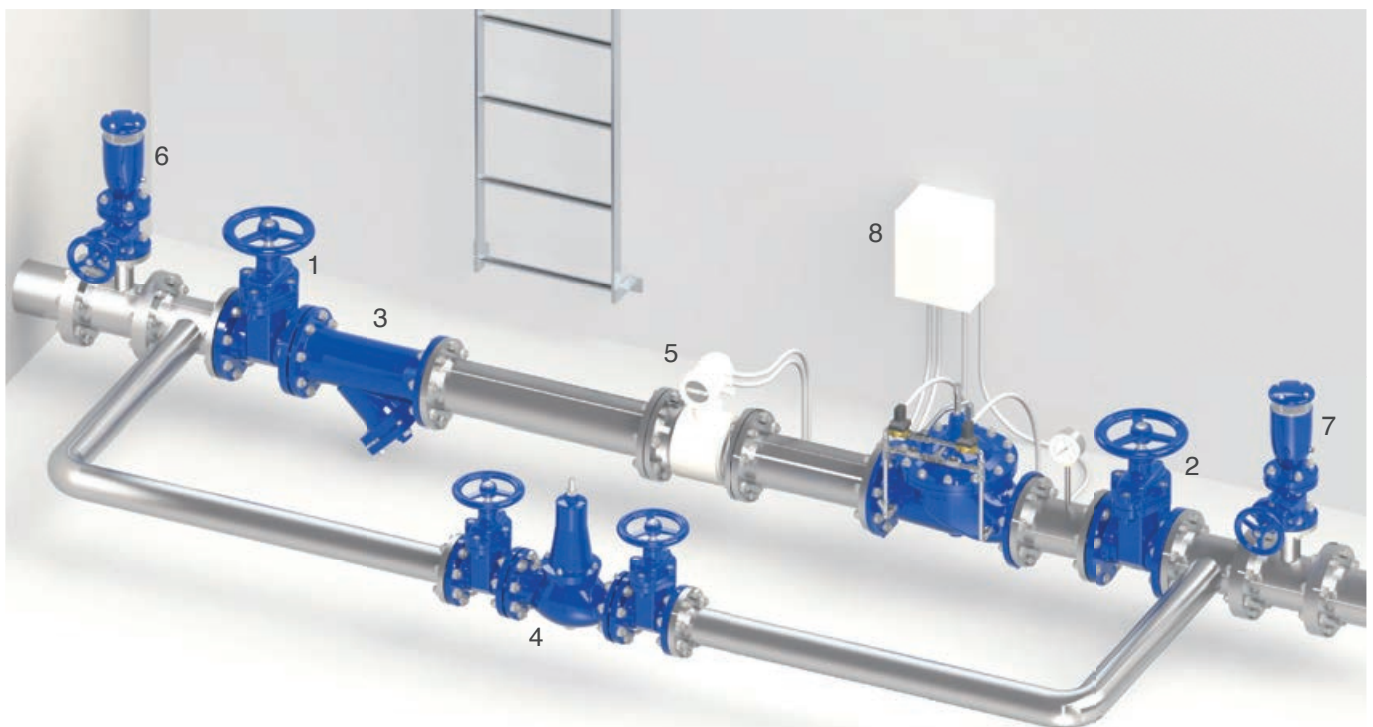





## Booster pump automatic control valve Mod. H-VAL 390/490

The PF Model H-VAL 390/490 is a globe pattern hydraulically operated automatic control valve, active check valve, that isolates the pump from the system during pump starting and stopping to prevent and avoid surges and water hammer events. The valve opens and closes in response to signals applied to the solenoid on the circuit where a needle valve will adjust the response time for an accurate and smooth regulation. Equipped with a limit switch activated by the position indicator's movement, made in ductile cast iron and stainless steel, the valve is designed to reduced head loss, throttling noise and cavitation damage.

### Applications

- At the pumps to enable start and stop cycles avoiding surges and water hammer.
- To prevent water hammer during pump switching in batteries and parallel operation.
- To ensure an accurate and surge free check prevention system.

### Accessories

- Pressure measurement kit.
- Self-flushing and high capacity filter.

### Note to the engineer

- PF anti-cavitation low flow stability plugs are recommended to provide an accurate regulation in case of low flow conditions.
- Recommended flow rate and operating conditions on the H-VAL series engineering.
- The duration of impulses sent to the solenoid is important and changes with valve size and operating pressure.

### Additional features

- H-VAL 491 booster pump pressure reducing valve.
- H-VAL 492 booster pump pressure sustaining control valve.
- H-VAL 493 booster pump with flow control valve.

### Working conditions

- Fluid: treated water.
- Minimum operating pressure: 0,7 bar.
- Maximum operating pressure: 16 bar. Higher on request.
- Maximum temperature: 70°C.

### Solenoid electrical data

- Voltages: 24 V DC, 24 V/50 Hz, 230 V/50 Hz. Other voltages on request.
- Power consumption: inrush AC (VA) 24, hold AC (VA) 17 (8 W), DC hot/cold coil 8/9 W.

## Operating principle (for DN 150-600)

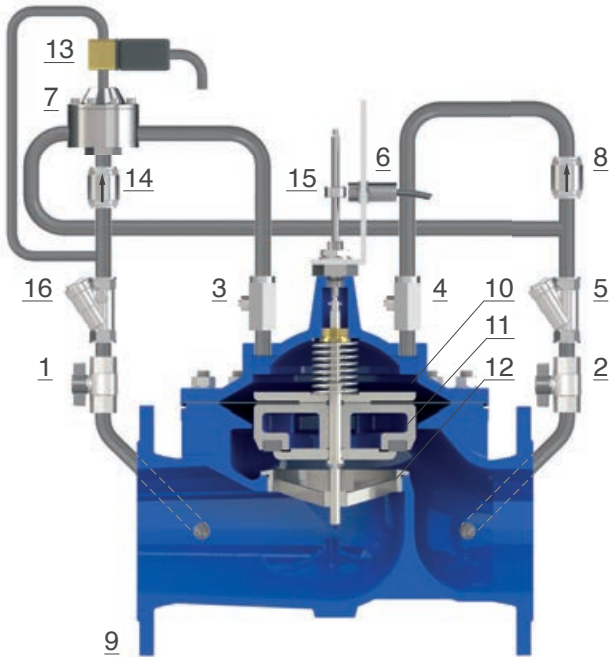

When pumps are turned off the valve (9) is closed and the solenoid (13) is de-energized. When the pump starts, the solenoid (13) is energized and the control chamber (10) is put in communication with the downstream pressure thanks to the hydraulic accelerator (7), thus pushing the obturator (11) upwards to generate a gradual increase of the flow rate.

The needle valve (3) ensures the regulation of the opening and closing speed, to avoid sudden variations in pressure. When shut down is required, the pump is kept running while the solenoid (13) is de-energized diverting, through the flow accelerator (7), the upstream pressure towards the control chamber (10) with gradual closing of the obturator (11) onto the seat (12). Once the indication rod (15) has reached a pre-determined position (adjustable, usually the 20% of the valve stroke), the limit switch (6) will send a signal for the pump to close. In case of power failure, the backflow through the main valve (9) is prevented thanks to the check valve (8) allowing the downstream pressure back to the control chamber (10) minimizing surges.

## Installation layout

The picture below shows the recommended installation layout of PF H-VAL 390/490 (1) as an effective surge prevention system and protection device for water pumping stations, in combination with PF pressure relief valves H-VAL model 420-R (2) or surge anticipating H-VAL model 421. Anti-slam combination air valves are recommended upstream (3) and downstream of the booster pump control as well as sectioning devices and bypass required for the proper maintenance.

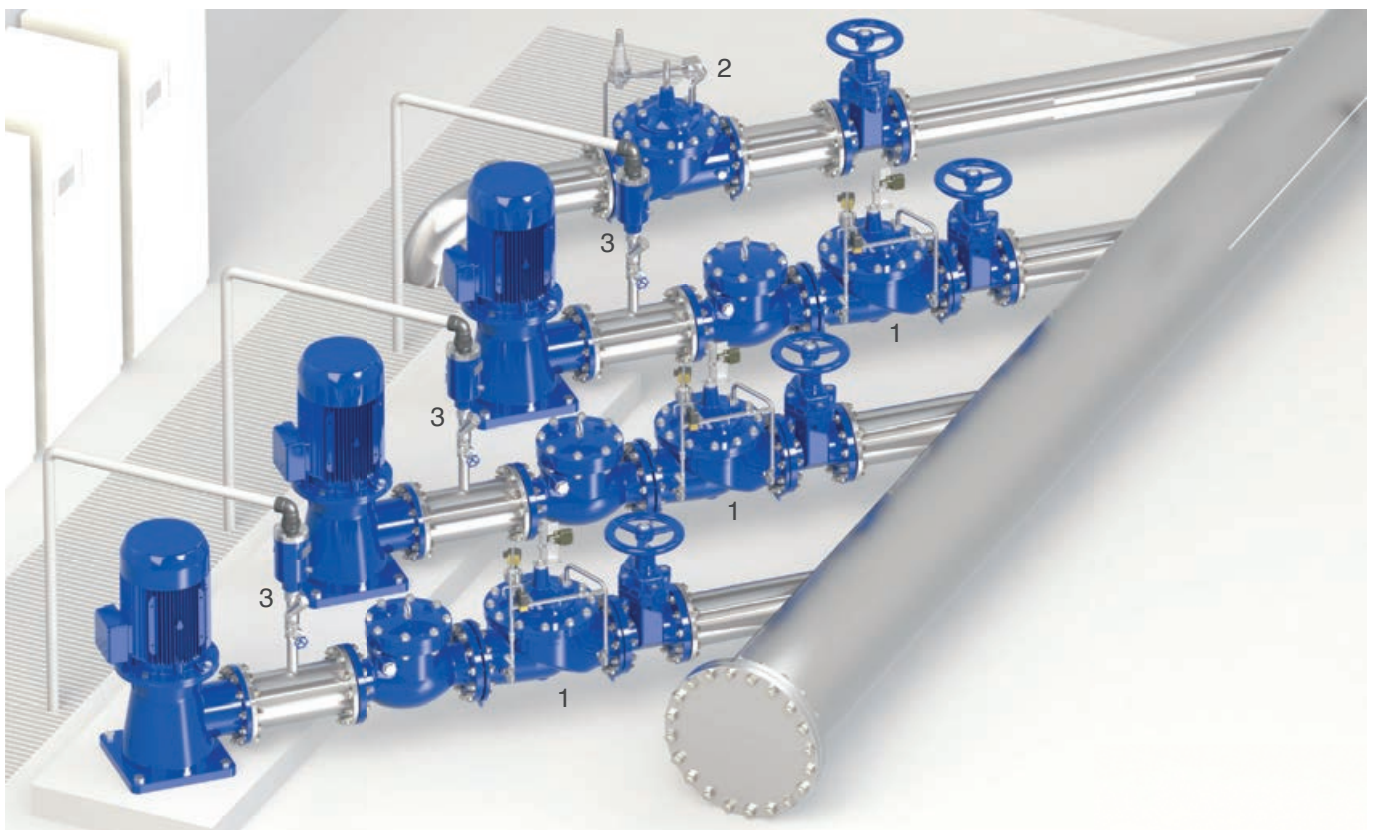



## Booster pump control and pressure sus- taining valve Mod. H-VAL 392/492

The PF Model H-VAL 392/492 is a globe pattern hydraulically operated automatic control valve, active check valve, that will automatically sustain the upstream pressure and isolate the pump from the system during pump starting and stopping to avoid surges and water hammer events. The valve opens and closes in response to signals applied to the solenoid on the circuit where the exclusive PF unit flow regulator GR.I.F.O will adjust the response time for an accurate and smooth regulation. Equipped with a limit switch activated by the position indicator's movement, the valve reduces head loss, throttling noise and cavitation damage.

### Applications

- At the pumps to enable start and stop cycles avoiding surges and water hammer maintaining a minimum upstream pressure.
- To prevent water hammer during pump switching in batteries and parallel operation.
- To ensure an accurate and surge free check prevention system.

### Accessories

- Pressure measurement kit.
- Self-flushing and high capacity filter.

### Note to the engineer

- PF anti-cavitation low flow stability plugs are recommended to provide an accurate regulation in case of low flow conditions.
- Recommended flow rate and operating conditions on the H-VAL series engineering.
- The duration of impulses sent to the solenoid is important and changes with valve size and operating pressure.

### Additional features

- XLC 491 booster pump pressure reducing valve.
- XLC 493 booster pump with flow control valve.

### Working conditions

- Fluid: treated water.
- Minimum operating pressure: 0,7 bar.
- Maximum operating pressure: 16 bar. Higher on request.
- Maximum temperature: 70°C.

### Downstream pressure pilot adjustment range

- Blue spring: 0,7 to 7 bar.
- Red spring: 1,5 to 15 bar.
- Values lower than 0,7 available with high sensitivity pilots.

### Solenoid electrical data

- Voltages: 24 V DC, 24 V/50 Hz, 230 V/50 Hz. Other voltages on request.
- Power consumption: inrush AC (VA) 24, hold AC (VA) 17 (8 W), DC hot/cold coil 8/9 W.



## Operating principle (for DN 150-800)

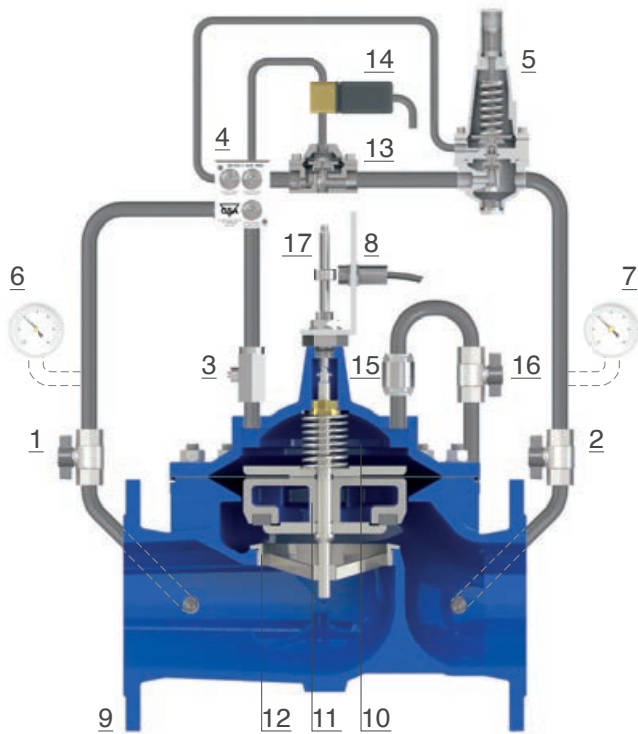

When the pump starts, should the upstream pressure be above the pilot set-point the solenoid (14) is energized with consequent opening of the auxiliary valve (13), which allows flow out of the main chamber (10) thus pushing the obturator (11) upwards to generate a gradual increase of the flow rate through the main valve. The upstream pressure sustaining pilot (5) will always maintain a minimum pre-set value to make sure the incoming pressure will never drop below it. When shut down is required, the pump is kept running while the solenoid (14) is de-energized closing the flow accelerator (13), diverting pressure towards the control chamber (10) with gradual closing of the obturator (11) onto the seat (12). Once the indication rod (17) has reached a pre-determined position (adjustable, usually the 20% of the valve stroke), the limit switch (8) will send a signal for the pump to close. In case of power failure, the backflow through the main valve (9) is prevented thanks to the check valve (15) allowing the downstream pressure back to the control chamber (10) minimizing surges.

## Installation layout

The picture below shows the recommended installation layout of PF H-VAL 392/492 (1) as an effective surge prevention system and protection device for water pumping stations, in combination with PF pressure relief valves H-VAL model 420-R (2) or surge anticipating H-VAL model 421. Anti-slam combination air valves are recommended upstream (3) and downstream of the booster pump control as well as sectioning devices and bypass required for the proper maintenance.

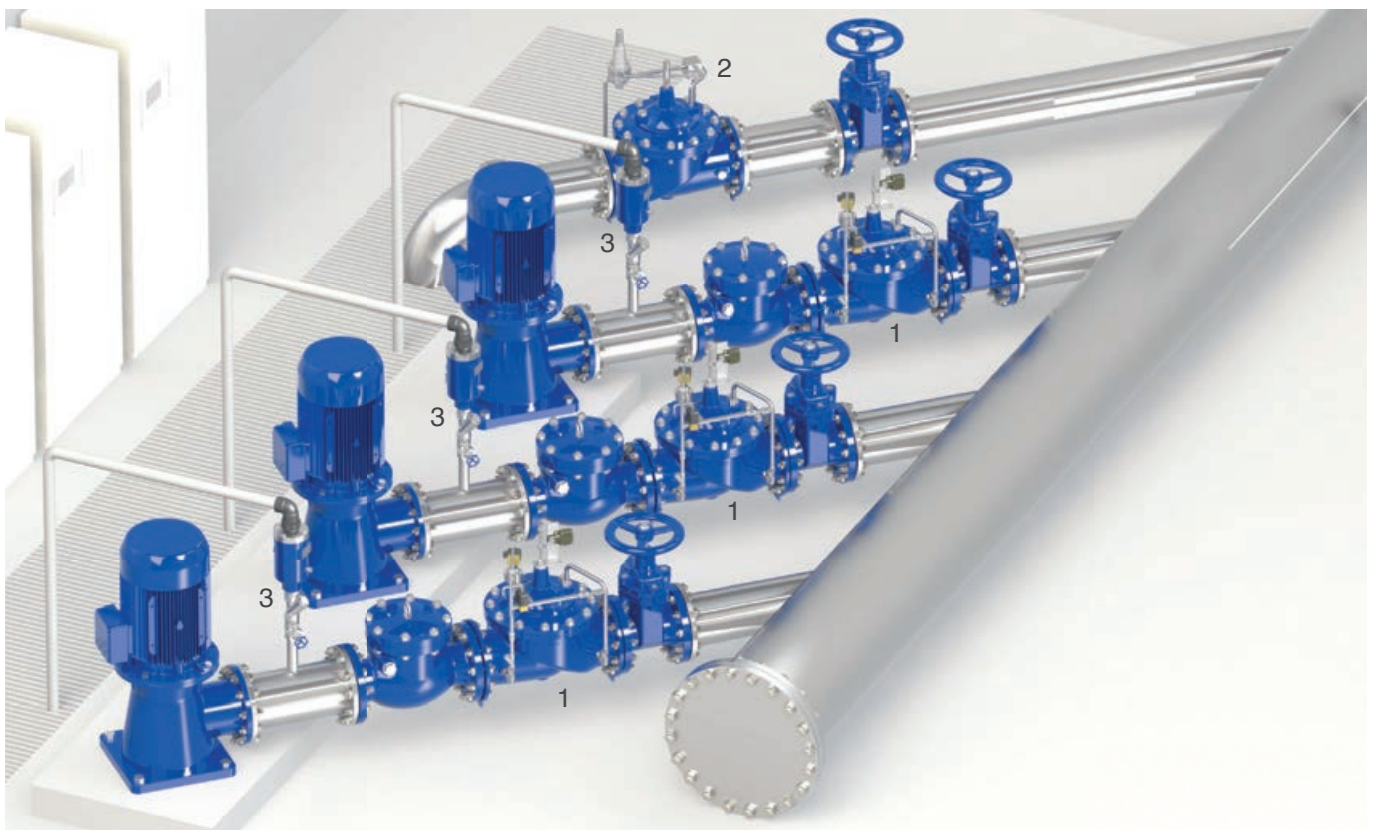

## Direct acting pressure reducing-stabilizing valve Mod. Microstab MRV

The Microstab MRV model is a two ways direct acting downstream pressure reducing-stabilizing valve. Diaphragm operated, the MRV will maintain an outlet pressure, preset and adjustable, to a fixed value regardless of variation of the upstream pressure and demand. This product is normally used for the regulation of H-VAL/H-FLUX series and, due to its high sensitivity, accuracy and long lasting performances, as a stand-alone unit for water distribution systems, industrial installation, buildings. Supplied with a wide choice of optional materials and spring range, MRV is available with the versions PN 16, 25 and 40 bar on request with reinforced diaphragm.

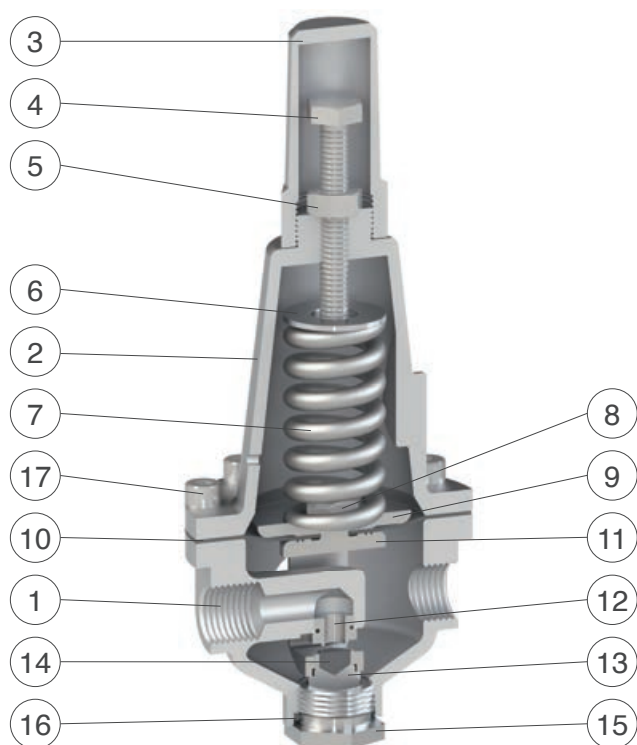

N.	Component	Material
1	Body	nickel-plated bronze/st. steel
2	Cover	nickel-plated bronze/st. steel
3	Hood	stainless steel
4	Regulating screw	stainless steel
5	Nut	stainless steel
6	Spring guide	stainless steel
7	Spring	painted steel 52SiCrNi5/st. st.
8	Self-locking nut	stainless steel
9	Upper flat	stainless steel
10	Diaphragm	EPDM - Nylon
11	Obturator holder	stainless steel
12	Sealing seat	stainless steel
13	Gasket holder	stainless steel
14	Plane gasket	NBR
15	Tap	stainless steel
16	O-ring	NBR
17	Screw	stainless steel

The list of materials and components is subject to changes without notice.

### Working conditions

Treated water maximum 70°C.  
Minimum pressure: 0,5 bar in addition to head loss.  
Maximum pressure: 25 bar.  
Higher on request.

### Technical data

Kv equal to 0,82 m<sup>3</sup>/h.  
Recommended flow rate: 0,5 m<sup>3</sup>/h.  
Weight 1,55 Kg.  
Normally supplied with 3/8" F.

### Downstream pressure adjustment

Spring	Pressure range (bar)
blue	0,7 - 7
red	1,5 - 15

Higher values available on request.

### Standard

Design and testing in accordance with EN 1074.

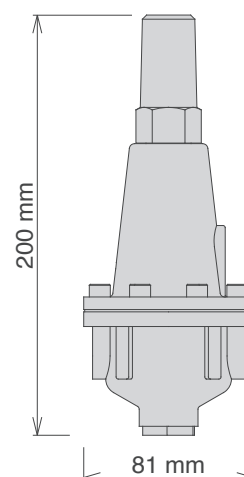

# Direct acting pressure reducing-stabilizing valve Mod. Microstab MRV 2

The Microstab MRV 2 model is a two ways direct acting downstream pressure reducing-stabilizing valve with pressure sensing port. Diaphragm operated, the MRV 2 will maintain an outlet pressure, preset and adjustable, to a fixed value regardless of variation of the upstream pressure and demand. This product is normally used for the regulation of H-VAL/H-FLUX series and, due to its high sensitivity, accuracy and long lasting performances, as a stand-alone unit for water distribution systems, industrial installation, buildings. Supplied with a wide choice of optional materials and spring range, MRV 2 is available with the PN 16 and 25 bar versions.

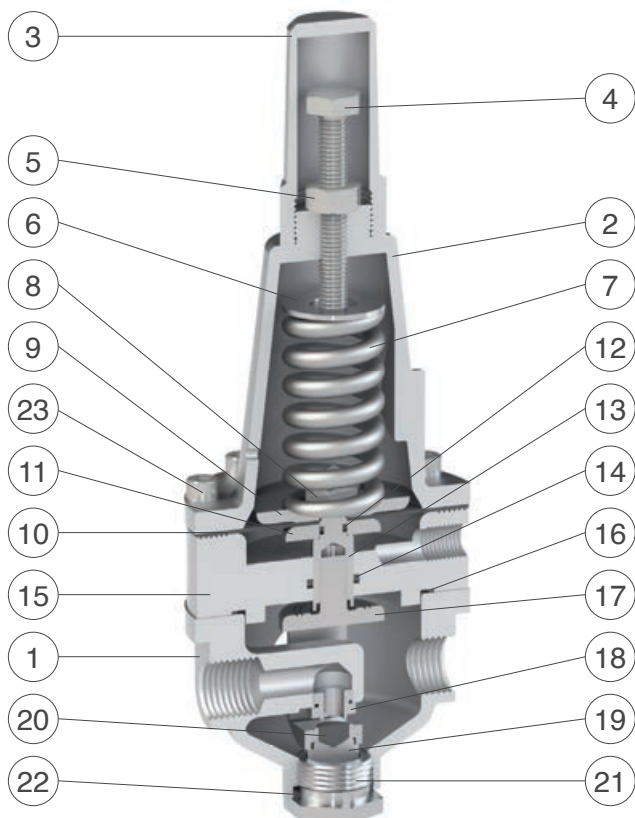

N.	Component	Material
1	Body	nickel-plated bronze/st. steel
2	Cover	nickel-plated bronze/st. steel
3	Hood	stainless steel
4	Regulating screw	stainless steel
5	Nut	stainless steel
6	Spring guide	stainless steel
7	Spring	painted steel 52SiCrNi5/st. st.
8	Self-locking nut	stainless steel
9	Upper flat	stainless steel
10	Diaphragm	EPDM - Nylon
11	Diaphragm lower disk	stainless steel
12	O-ring	NBR
13	Shaft	stainless steel
14	O-ring	NBR
15	Intermediate body	stainless steel
16	O-ring	NBR
17	Obturator holder	stainless steel
18	Sealing seat	stainless steel
19	Gasket holder	stainless steel
20	Plane gasket	NBR
21	Tap	stainless steel
22	O-ring	NBR
23	Screws	stainless steel

The list of materials and components is subject to changes without notice.

## Working conditions

Treated water maximum 70°C.  
Minimum pressure: 0,5 bar in addition to head loss.  
Maximum pressure: 25 bar.  
Higher on request.

## Technical data

Kv equal to 0,82 m<sup>3</sup>/h.  
Recommended flow rate: 0,5 m<sup>3</sup>/h.  
Weight 2,25 Kg.  
Normally supplied with 3/8" F.

## Downstream pressure adjustment

Spring	Pressure range (bar)
blue	0,7 - 7
red	1,5 - 15

Higher values available on request.

## Standard

Design and testing in accordance with EN 1074.

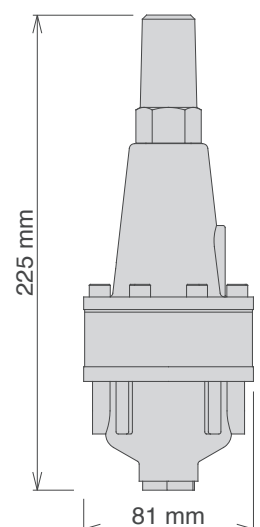



## Direct acting pressure sustaining valve Mod. Microstab MSM

The Microstab MSM model is a two ways direct acting upstream pressure sustaining valve. Diaphragm operated, the MSM will maintain an inlet pressure, preset and adjustable, to a fixed value regardless of variation of the downstream pressure and demand. This product is normally used for the regulation of H-VAL/H-FLUX series and, due to its high sensitivity accuracy and long lasting performances, as a stand-alone unit for water distribution systems, industrial installation, buildings. Supplied with a wide choice of optional materials and spring range, MSM is available with the versions PN 16, 25 and, on request, 40 bar with reinforced diaphragm.

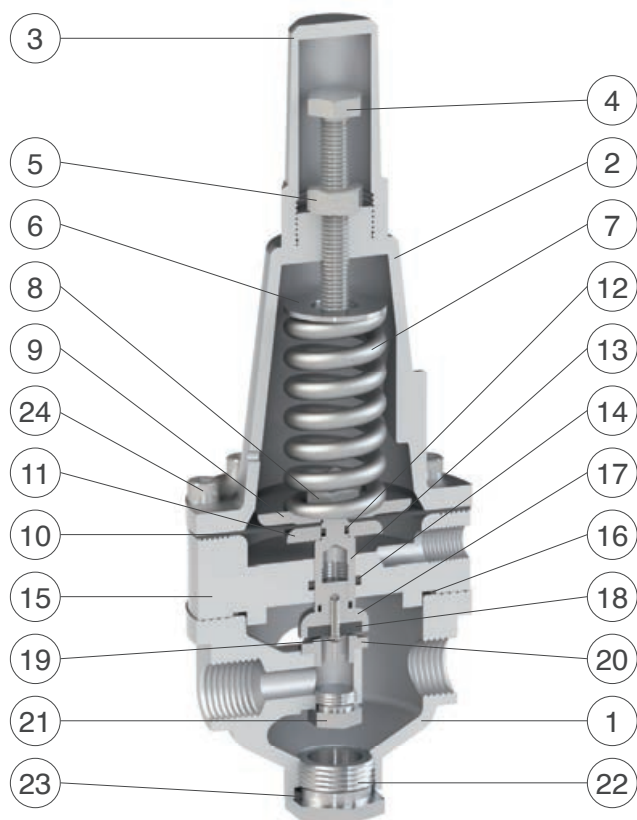

N.	Component	Material
1	Body	nickel-plated bronze/st. steel
2	Cover	nickel-plated bronze/st. steel
3	Hood	stainless steel
4	Regulating screw	stainless steel
5	Nut	stainless steel
6	Spring guide	stainless steel
7	Spring	painted steel 52SiCrNi5/st. st.
8	Self-locking nut	stainless steel
9	Upper flat	stainless steel
10	Diaphragm	EPDM - Nylon
11	Diaphragm lower disk	stainless steel
12	O-ring	NBR
13	Shaft	stainless steel
14	O-ring	NBR
15	Intermediate body	stainless steel
16	O-ring	NBR
17	Gasket container	stainless steel
18	Gasket	NBR
19	Screw	stainless steel
20	Sealing seat	stainless steel
21	Tap	stainless steel
22	Tap	stainless steel
23	O-ring	NBR
24	Screws	stainless steel

The list of materials and components is subject to changes without notice.

### Working conditions

Treated water maximum 70°C.  
Minimum pressure: 0,5 bar in addition to head loss.  
Maximum pressure: 25 bar.  
Higher on request.

### Upstream pressure adjustment

Spring	Pressure range (bar)
blue	0,7 - 7
red	1,5 - 15

Higher values available on request.

### Technical data

Kv equal to 0,9 m<sup>3</sup>/h.  
Recommended flow rate: 0,5 m<sup>3</sup>/h.  
Weight 2,23 Kg.  
Normally supplied with 3/8" F.

### Standard

Design and testing in accordance with EN 1074.

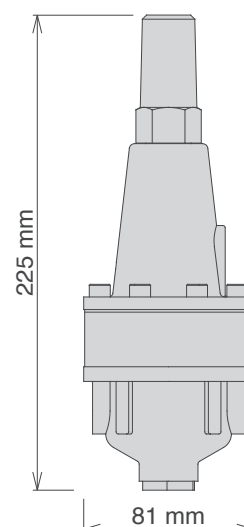

## Direct acting quick pressure relief valve Mod. Microstab PSM

The Microstab PSM model is a two ways fast acting relief valve. Diaphragm operated, the PSM will discharge the excessive inlet pressure values, according to a preset and adjustable spring set point, regardless of variations of the downstream pressure and demand. This product is normally used for the regulation of H-VAL/H-FLUX series and, due to its high sensitivity and accuracy and long lasting performances, as a stand-alone unit for water distribution systems, industrial installation, buildings. Supplied with a wide choice of optional materials and spring range, PSM is available with the PN 16 and 25 bar versions.

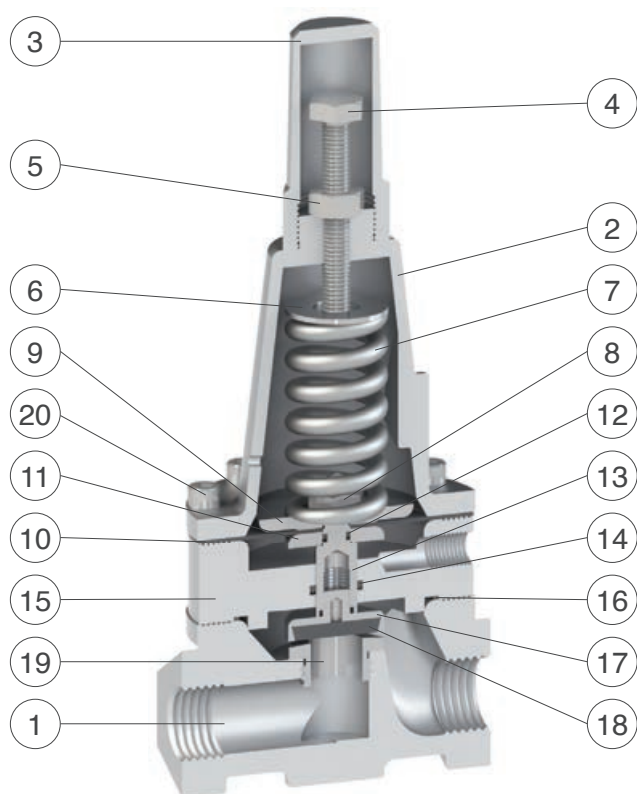

N.	Component	Material
1	Body	nickel-plated bronze/st. steel
2	Cover	nickel-plated bronze/st. steel
3	Hood	stainless steel
4	Regulating screw	stainless steel
5	Nut	stainless steel
6	Spring guide	stainless steel
7	Spring	painted steel 52SiCrNi5/st. st.
8	Self-locking nut	stainless steel
9	Upper flat	stainless steel
10	Diaphragm	EPDM - Nylon
11	Diaphragm lower disk	stainless steel
12	O-ring	NBR
13	Shaft	stainless steel
14	O-ring	NBR
15	Intermediate body	stainless steel
16	O-ring	NBR
17	Gasket container	stainless steel
18	Gasket	NBR
19	Sealing seat	stainless steel
20	Screws	stainless steel

The list of materials and components is subject to changes without notice.

### Working conditions

Treated water maximum 70°C.  
Minimum pressure: 0,5 bar in addition to head loss.  
Maximum pressure: 25 bar.  
Higher on request.

### Technical data

Kv equal to 3,5 m<sup>3</sup>/h.  
Recommended flow rate: 2,1 m<sup>3</sup>/h.  
Weight 2,37 Kg.  
Normally supplied with 1/2" F.

### Relief pressure adjustment

Spring	Pressure range (bar)
blue	0,7 - 7
red	1,5 - 15

Higher values available on request.

### Standard

Design and testing in accordance with EN 1074.

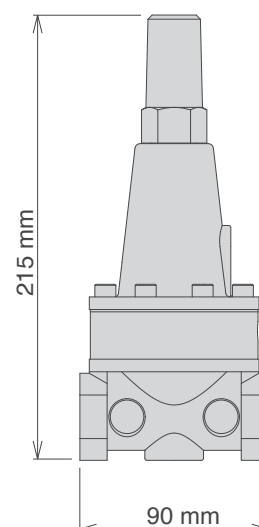

## Flow control valve Mod. Microstab MLP

The Microstab MLP model is a two ways direct acting flow control valve. Diaphragm operated, the MLP will limit the maximum flow rate, preset and adjustable, to a fixed value regardless of upstream pressure variations where an additional adjustable assembly unit is required. This product is normally used for the regulation of H-VAL/H-FLUX series and, due to its high sensitivity, accuracy and long lasting performances, as a stand-alone unit for water distribution systems, industrial installation, buildings. Supplied with a wide choice of optional materials, and available with the PN 16 and 25 bar version, MLP is provided with a flow rate regulation chart for on-site adjustments according to the compression of the spring.

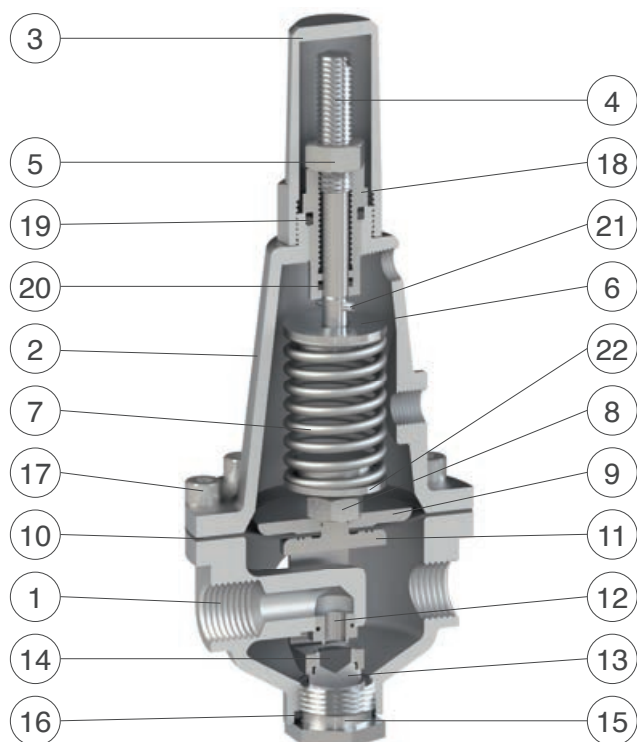

N.	Component	Material
1	Body	nickel-plated bronze/st. steel
2	Cover	nickel-plated bronze/st. steel
3	Hood	stainless steel
4	Driving screw	stainless steel
5	Nut	stainless steel
6	Upper spring guide	stainless steel
7	Spring	stainless steel
8	Self-locking nut	stainless steel
9	Upper flat	stainless steel
10	Diaphragm	EPDM - Nylon
11	Obturator holder	stainless steel
12	Sealing seat	stainless steel
13	Gasket holder	stainless steel
14	Plane gasket	NBR
15	Tap	stainless steel
16	O-ring	NBR
17	Screw	stainless steel
18	Water tight spacer	stainless steel
19	O-ring	NBR
20	O-ring	NBR
21	Stop pin	stainless steel
22	Lower spring guide	stainless steel

The list of materials and components is subject to changes without notice.

### Note to the engineer

For the functioning an orifice plate assembly is required downstream, to generate the differential pressure necessary to balance the spring force inside the cover and sized according to the flow rate requirement.

### Technical data

Kv equal to 0,9 m<sup>3</sup>/h.  
Weight 1,65 Kg.  
Normally supplied with 3/8" F.

### Working conditions

Treated water maximum 70°C.  
Minimum pressure: 0,5 bar in addition to head loss.  
Maximum pressure: 16 bar.  
Higher on request.

### Standard

Design and testing in accordance with EN 1074.

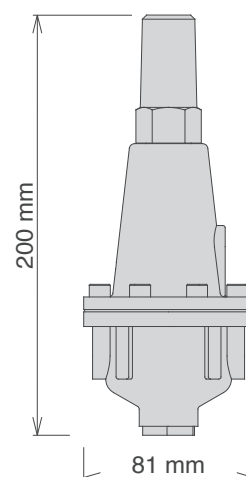



# High sensitivity altitude/pressure reduction pilot Mod. Microstab MPZ

The Microstab MPZ model is a two ways direct acting modulating valve with remote sensing intermediate chamber. Diaphragm operated, the MRV will maintain a preset and adjustable tank level, whose static value is sensed through a dedicated pressure port, with an accurate and proportional modulating effect acting against the spring force located on the cover. This product is normally used for the regulation of H-VAL 470 control valves, designed for high sensitivity level control. Supplied with optional materials and different springs MPZ can also be used as independent altitude level/pressure reduction control valve.

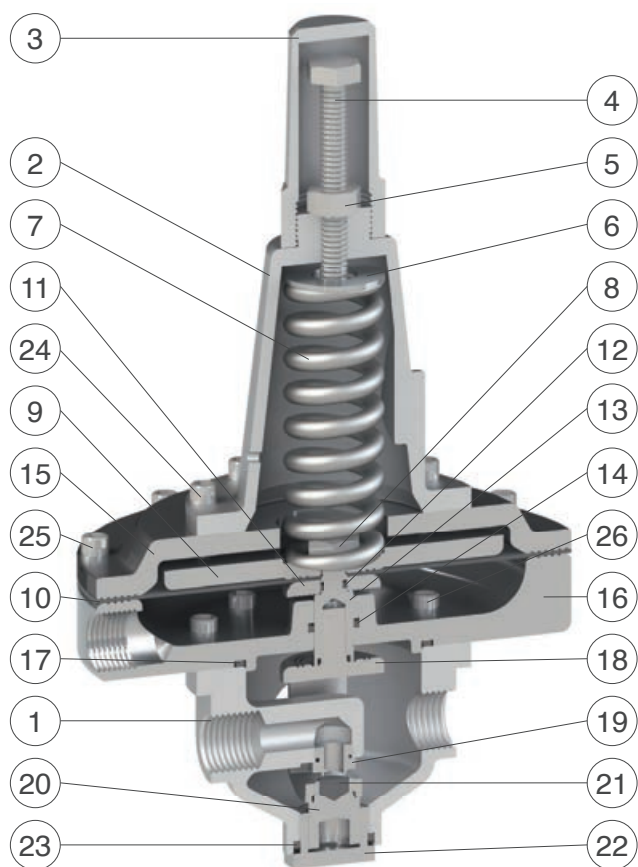

N.	Component	Material
1	Body	nickel-plated bronze/st. steel
2	Cover	nickel-plated bronze/st. steel
3	Hood	stainless steel
4	Regulating screw	stainless steel
5	Nut	stainless steel
6	Spring guide	stainless steel
7	Spring	painted steel 52SiCrNi5/st. st.
8	Self-locking nut	stainless steel
9	Upper flat	stainless steel
10	Diaphragm	EPDM - Nylon
11	Diaphragm lower disk	stainless steel
12	O-ring	NBR
13	Shaft	stainless steel
14	O-ring	NBR
15	Upper flange	nickel-plated brass/st. steel
16	Lower flange	nickel-plated brass/st. steel
17	O-ring	NBR
18	Obturator holder	stainless steel
19	Sealing seat	stainless steel
20	Gasket holder	stainless steel
21	Plane gasket	NBR
22	Tap	stainless steel
23	O-ring	NBR
24	Screws	stainless steel
25	Screws	stainless steel
26	Screws and O-rings	stainless steel and NBR

The list of materials and components is subject to changes without notice.

## Working conditions

Treated water maximum 70°C.  
Minimum pressure: 0,5 bar in addition to head loss.  
Maximum pressure: 16 bar.  
Recommended working pressure: 6 bar. Higher on request.

## Level adjustment

Spring	Level adjustment (m)
blue	3,8 - 18
red	6 - 40

Different values available on request.

## Technical data

Kv equal to 0,82 m<sup>3</sup>/h.  
Weight 4,65 Kg.  
Normally supplied with 3/8" F.

## Standard

Design and testing in accordance with EN 1074.

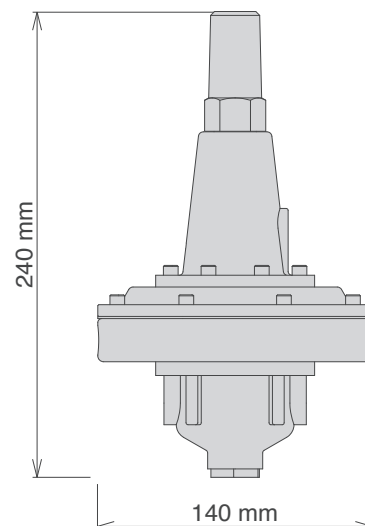

## Two and three ways flow accelerators Mod. A2 and A3

The PF hydraulic auxiliary valve, hydraulic relay, flow accelerator, is available in a two and three ways versions, namely A2 and A3, depending on the application and on the valve size for which it is required. This unit is a diaphragm actuated valve, operated in response to pressure applied to its control chamber, designed to be used on the circuits of the PF H-VAL/H-FLUX control valves series in order to enhance hydraulic capacity increasing at the same time performances and reliability. Used for a wide number of applications, the PF A2 and A3 stand out for long lasting performances due to the choice of high quality materials and its design features.

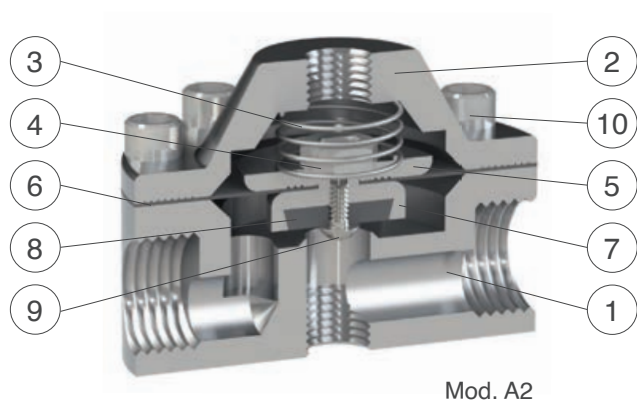

### Mod. A2

N.	Component	Material
1	Body	stainless steel
2	Cover	stainless steel
3	Spring	stainless steel
4	Nut	stainless steel
5	Disk	stainless steel
6	Diaphragm	EPDM - Nylon
7	Obturator	stainless steel
8	Plane gasket	NBR
9	Screw	stainless steel
10	Screws	stainless steel

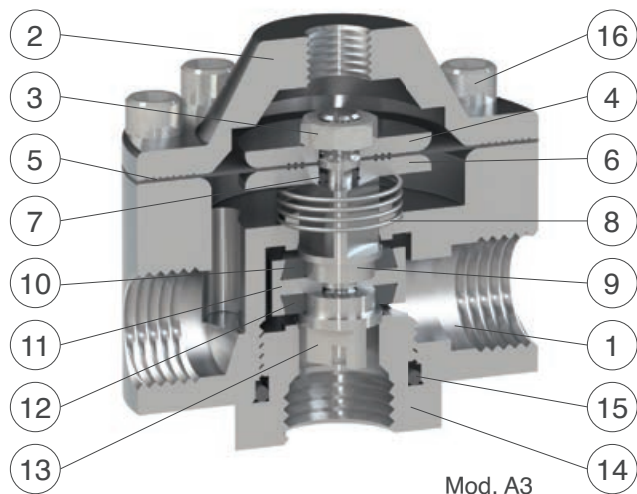

### Mod. A3

N.	Component	Material
1	Body	stainless steel
2	Cover	stainless steel
3	Nut	stainless steel
4	Disk	stainless steel
5	Diaphragm	EPDM - Nylon
6	Disk	stainless steel
7	O-ring	NBR
8	Spring	stainless steel
9	Shaft	stainless steel
10	Gasket	NBR
11	Obturator	stainless steel
12	Gasket	NBR
13	Guiding nut	stainless steel
14	Lower seat	stainless steel
15	O-ring	NBR
16	Screws	stainless steel

The list of materials and components is subject to changes without notice.

### Working conditions

Treated water maximum 70°C.  
Maximum pressure: 25 bar.

### Technical data

A2 Kv: 1,4 m<sup>3</sup>/h.  
A3 globe pattern Kv: 0,93 m<sup>3</sup>/h.  
A3 angle pattern Kv: 1,1 m<sup>3</sup>/h.  
A2 weight: 0,58 Kg. A3 weight: 0,74 Kg.  
Normally supplied with 3/8" F.

### Standard

Design and testing in accordance with EN 1074.

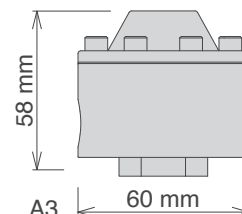
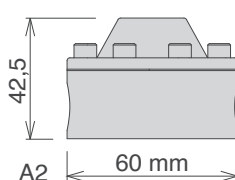

## Visual position indicator Mod. CSPV

The PF visual position indicator Mod. CSPV is designed to visually and easily display the valve position and regulation behaviour. The valve's indication rod shows the opening percentage of the internal mobile block, moving into a transparent tube with a solid stainless steel/nickel plated brass housing. The latter, open on two opposite sides for a clear vision, is provided with a manual air release system on top in order to allow air discharge during set up and maintenance. Supplied as a standard position indicator tool for PF valves, the Mod. CSPV can be replaced by the linear 4-20 mA, on-off position transmitters or the mechanical flow regulator.

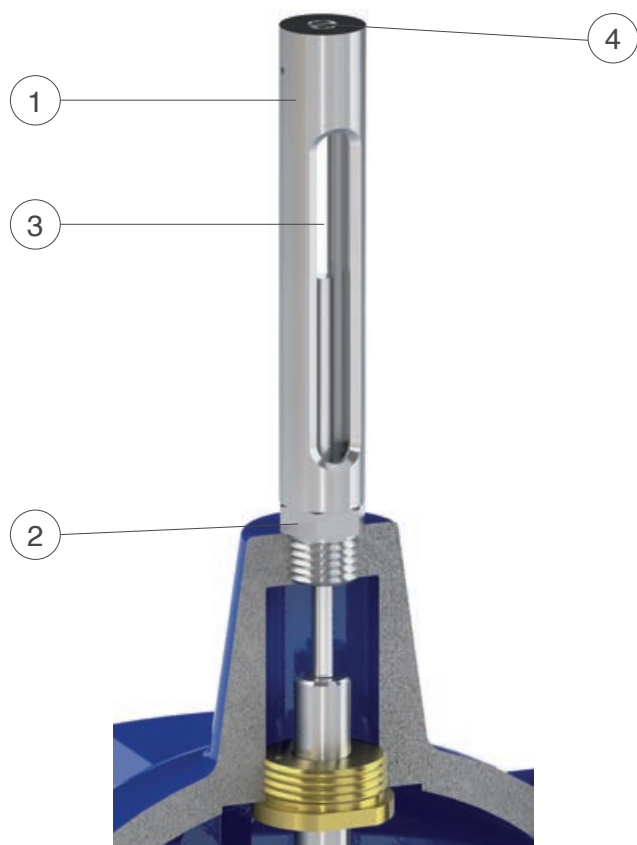

N.	Component	Material
1	Upper part	stainless steel
2	Lower part	stainless steel
3	Glass pipe	Pyrex glass
4	Rod	stainless steel

The list of materials and components is subject to changes without notice.

### Working conditions

Treated water maximum 70°C.  
Maximum pressure: 25 bar.

### Standard

Design and testing in accordance with EN 1074.

### Weight and dimensions

Valve DN	A (mm)	Weight (Kg)
from 50 to 125	82	0,23
from 150 to 250	110	0,27
from 300 to 600	175	0,36

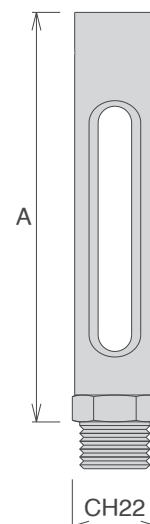



## On-off position transmitter assembly Mod. CSPO

The PF position indicator assembly model CSPO has been designed to be installed on every H-VAL/H-FLUX control valves series with the purpose of providing on-off signals in relation to one or two points, normally corresponding to the opened and closed positions. The CSPO is operated by means of magnets fixed on the control valve's indication stem whose movement will provide the required signal when going through the sensing area of magnetic inductive proximity sensors, located on a bracket.

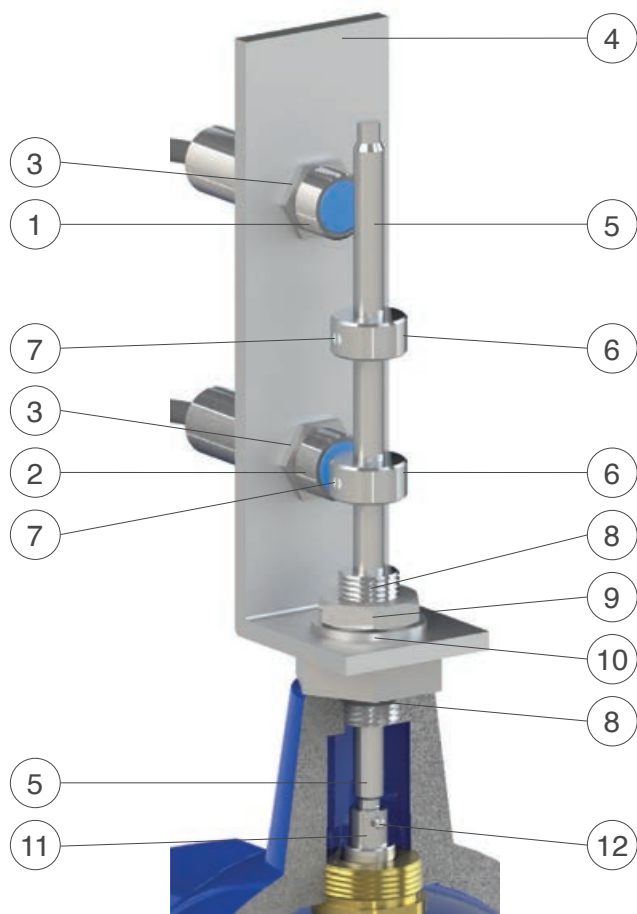

N.	Component	Material
1	Open valve proximity sensor	nickel-plated brass
2	Close valve proximity sensor	nickel-plated brass
3	Locking nuts	aluminium
4	Bracket	stainless steel
5	Stem	stainless steel
6	Sensor indicator disks	stainless steel
7	Screws	stainless steel
8	Guiding nut	stainless steel
9	Nut	stainless steel
10	Washer	stainless steel
11	Connecting screw	stainless steel
12	Stop pin	stainless steel

The list of materials and components is subject to changes without notice.

### Working conditions

Treated water maximum 70°C.  
Maximum pressure: 25 bar.

### Standard

Design and testing in accordance with EN 1074.

### Technical data

Power supply: 12-24 V DC.  
Protection: IP69, IP68.

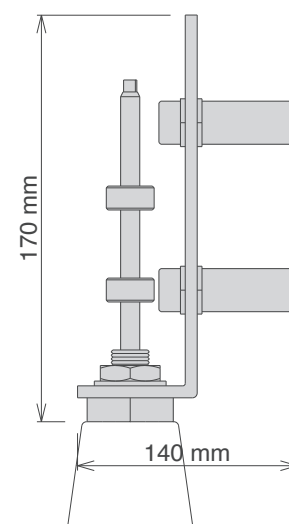

## Contactless linear position transducer with magnetostrictive technology - Mod. CSPL

The linear position transmission system model CSPL has been designed to be installed on H-VAL/H-FLUX control valves series with the purpose of providing a 4-20 mA output, in relation to the opening percentage. It is operated by means of a magnet fixed on the control valve's indication stem, whose movement will impart the required signal through a contactless technology. The CSPL is usually supplied with step by step or pressure management H-VAL/H-FLUX control valve, although it can be assembled on any existing PF valve simply by replacing few components.

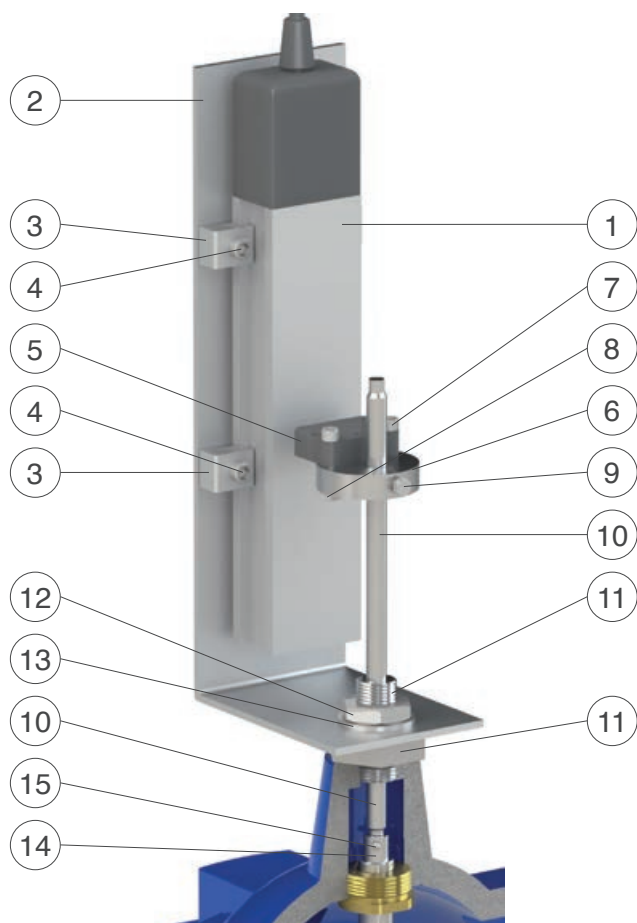

N.	Component	Material
1	Position transducer	aluminium
2	Bracket	stainless steel
3	Bracket connections	aluminium
4	Screws	stainless steel
5	Magnet	stainless steel
6	Magnet support	stainless steel
7	Screws	stainless steel
8	Nuts	stainless steel
9	Screw	stainless steel
10	Stem	stainless steel
11	Guiding nut	stainless steel
12	Nut	stainless steel
13	Washer	stainless steel
14	Connecting screw	stainless steel
15	Mechanical stop pin	stainless steel

The list of materials and components is subject to changes without notice.

### Working conditions

Treated water maximum 70°C.  
Maximum pressure: 25 bar.

### Standard

Design and testing in accordance with EN 1074.

### Technical data

Power supply: 24 V DC  $\pm$  20%.  
Output signal: 4-20 mA.  
Protection: IP67.

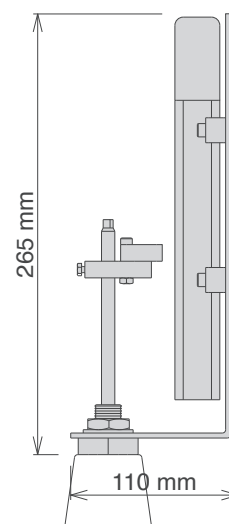

## Three ways on-off level vertical float for minimum and maximum tank regulation - Mod. Rotoway

The PF assembly for minimum and maximum level control, named Rotoway, is composed of a three ways body in stainless steel and all the accessories to provide a fully independent unit designed to operate on PF control valves H-VAL/H-FLUX series. Internals and construction details make Rotoway suitable for long operating cycles also in presence of high differential pressure, with the level control regulation range up to 4 m length. The operating principle is based upon the movement of the float that, sliding on a wire, imparts the force to the lever to switch from open to the closed positions, by means of mechanical stops corresponding to the minimum and maximum level of the tank, both pre-set and adjustable.

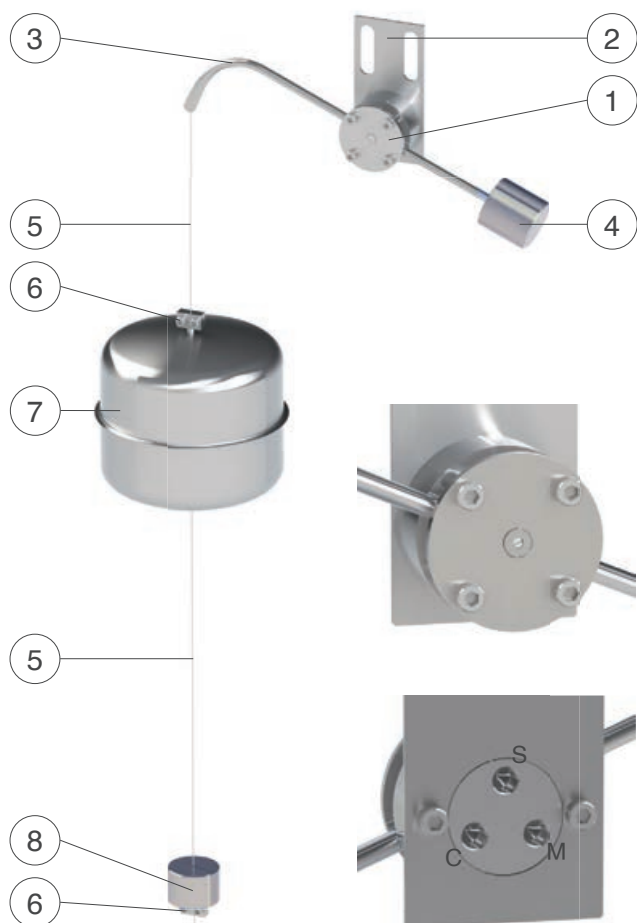

N.	Component	Material
1	Rotoway pilot	stainless steel, bronze, Delrin
2	Bracket	stainless steel
3	Rod	stainless steel
4	Counterweight	stainless steel
5	Wire	stainless steel
6	Stop collars	stainless steel
7	Float	stainless steel
8	Counterweight	stainless steel

The list of materials and components is subject to changes without notice.

### Front view

The picture shows the front view of the three ways Rotoway case, the screws in the middle is used to adjust and balance the lever linked to the float mechanism.

### Rear view

The picture shows the rear view of the three ways Rotoway case with pressure port connections, S for drain, C for chamber and M for upstream, used to operate the PF H-VAL/H-FLUX control valves according to the set up and installation manual.

### Working conditions

Treated water maximum 70°C.  
Design pressure: 16 bar.  
Recommended working pressure: 6 bar.  
Higher on request.

### Standard

Design and testing in accordance with EN 1074.

### Technical data

Normally supplied with 1/8" F.

### Installation

The Rotoway assembly is usually located on top of water level inside the main reservoir, although it can be installed in a stilling tank for better performances and maintenance purposes. The picture on the right shows the recommended size of the pipe, required for such application.

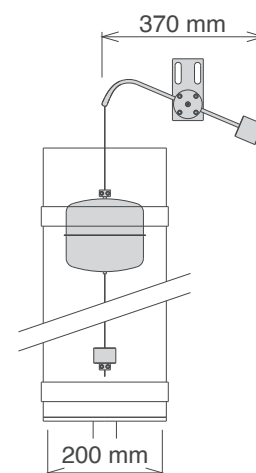



## Two ways modulating proportional constant level control pilot - Mod. MCP

The PF MCP is a two ways proportional modulating float valve, designed to maintain the constant level of a tank regardless of upstream pressure variations. This product, entirely made in stainless steel and created for the regulation of PF level control valves H-VAL/H-FLUX series, thanks to its high accuracy and reliability can also be used as a stand-alone unit for water distribution systems, industrial installations, buildings. MCP is actuated by a float, sensing the water level of the tank, and whose variation will impart a force to the lever to which it is connected in order to move the piston horizontally and modulate the flow passage between the seat and the obturator proportionally to the consumption.

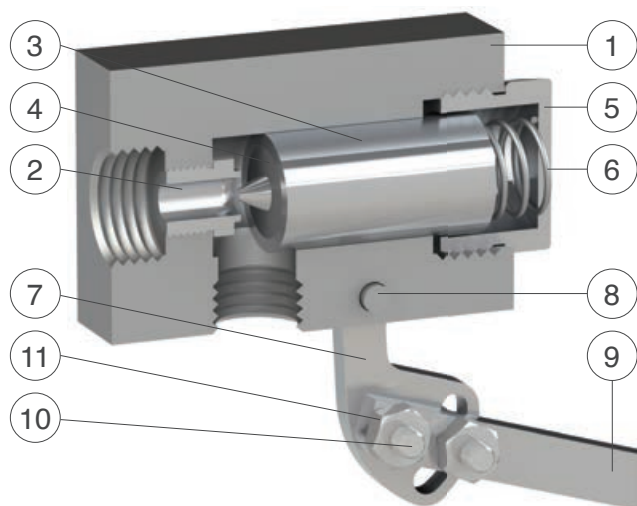

N.	Component	Material
1	Body	stainless steel
2	Seat	stainless steel
3	Obturator	stainless steel
4	Plane gasket	NBR
5	Tap	stainless steel
6	Spring	stainless steel
7	Lever	stainless steel
8	Pivot	stainless steel
9	Rod	stainless steel
10	Screws	stainless steel
11	Nuts	stainless steel
12	Float	stainless steel
13	Screw	stainless steel

The list of materials and components is subject to changes without notice.

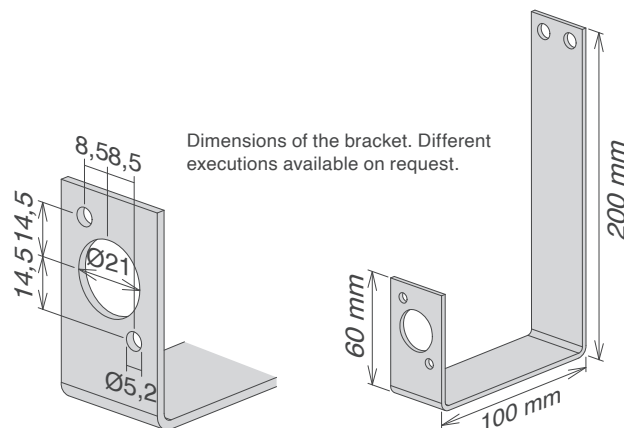

### Working conditions

Treated water maximum 70°C.  
 Design pressure: 16 bar.  
 Recommended working pressure: 6 bar.  
 Higher values on request.

### Standard

Design and testing in accordance with EN 1074.

### Technical data

Kv: 0,67 m<sup>3</sup>/h.  
 Stroke of the float: 85 mm, different on request.

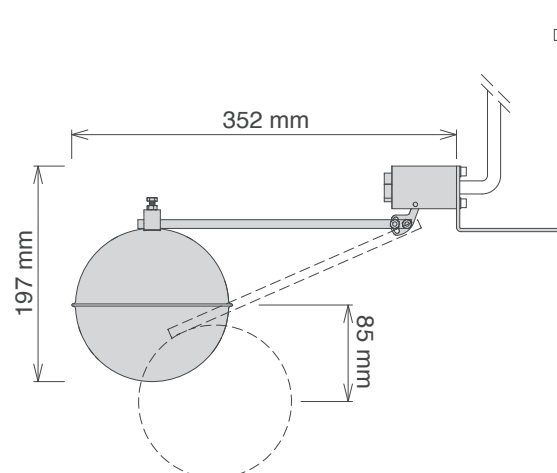

## On-off limit switch assembly Mod. CSLS

The PF limit switch assembly CSLS has been designed to be installed on every H-VAL/H-FLUX control valves series with the purpose of providing on-off signals in relation to the position. The activation point is given by the disk acting on the limit switch, adjustable to the required position. The entire assembly is located on a bracket in stainless steel holding the water tight nut threaded on the chamber while the stem is connected to the main shaft, by means of a bearing pin to allow for tolerance and unwanted friction during movement.

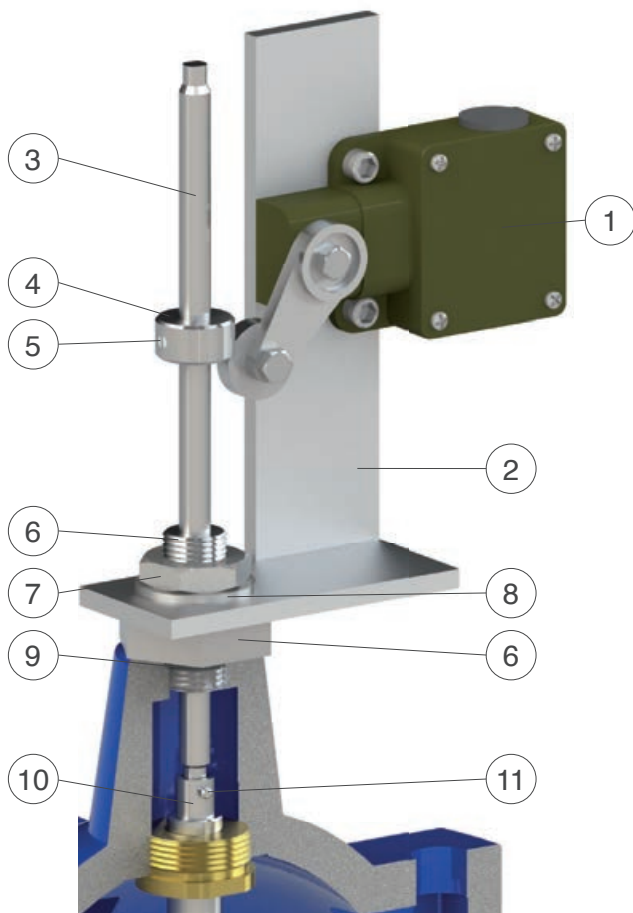

N.	Component	Material
1	Switch	steel/stainless steel
2	Bracket	stainless steel
3	Stem	stainless steel
4	Indicator disk	stainless steel
5	Screw	stainless steel
6	Guiding nut	stainless steel
7	Nut	stainless steel
8	Washer	stainless steel
9	O-ring	NBR
10	Connecting screw	stainless steel
11	Stop pin	stainless steel

The list of materials and components is subject to changes without notice.

### Technical data

Protection: IP67.

Metal case.

Different executions and more information on request.

### Standard

According to EN 60947-5-1, EN 60947-1, EN 60204-1, EN ISO 14119, EN ISO 12100, EN 60529.

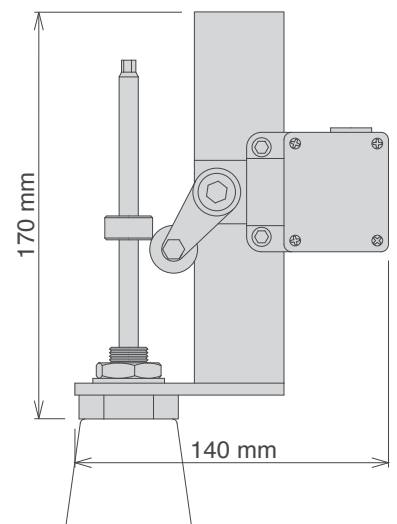

## Mechanical flow regulator Mod. CSFL

The PF mechanical flow regulator Mod. CSFL is designed for the manual control of the maximum opening percentage of the valve in working conditions. Entirely made in stainless steel this accessory can be installed on every model of PF H-VAL/H-FLUX series control valve, and replace existing position indicators, output signal and any other PF solutions located on top of the control chamber. The CSFL is mostly recommended for surge anticipation valves, surge relief, level control and whenever the possibility of the manual adjustment of the maximum flow may be needed for the proper regulation of the valve and the safety of the system.

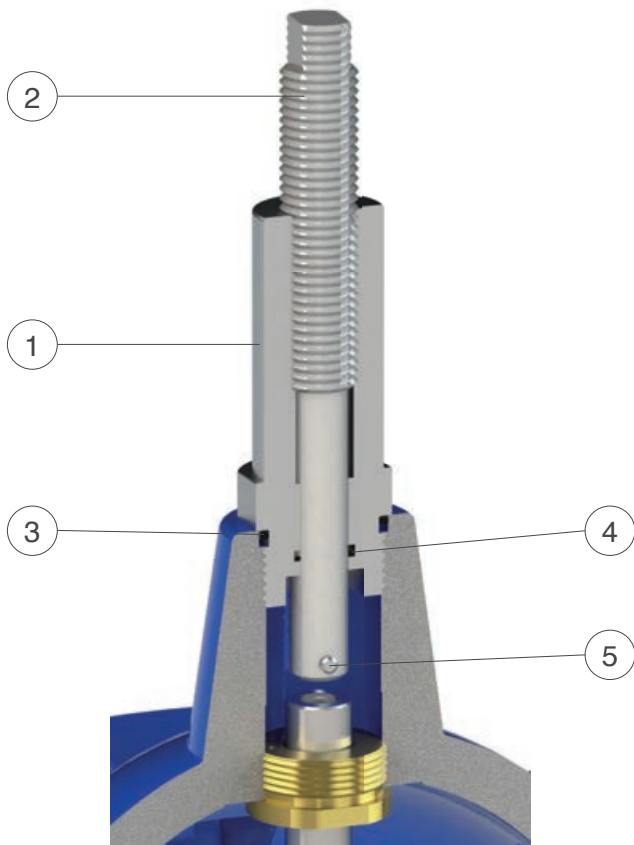

N.	Component	Material
1	Body	stainless steel
2	Regulating screw	stainless steel
3	O-ring	NBR/EPDM/Viton
4	O-ring	NBR/EPDM/Viton
5	Stop pin	stainless steel

The list of materials and components is subject to changes without notice.

### Working conditions

Treated water maximum 70°C.  
Maximum pressure: 25 bar.  
Higher values on request.

### Dimensions

Valve DN (mm)	A max. (mm)	B (mm)	C (mm)
50-65	95	CH24	CH8
80-100	121	CH30	CH10
150-200	199	CH42	CH15

Bigger sizes available on request.

### Standard

Design and testing in accordance with EN 1074.

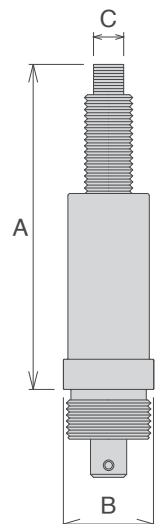

## H-VAL 400 - Standard version - Technical details

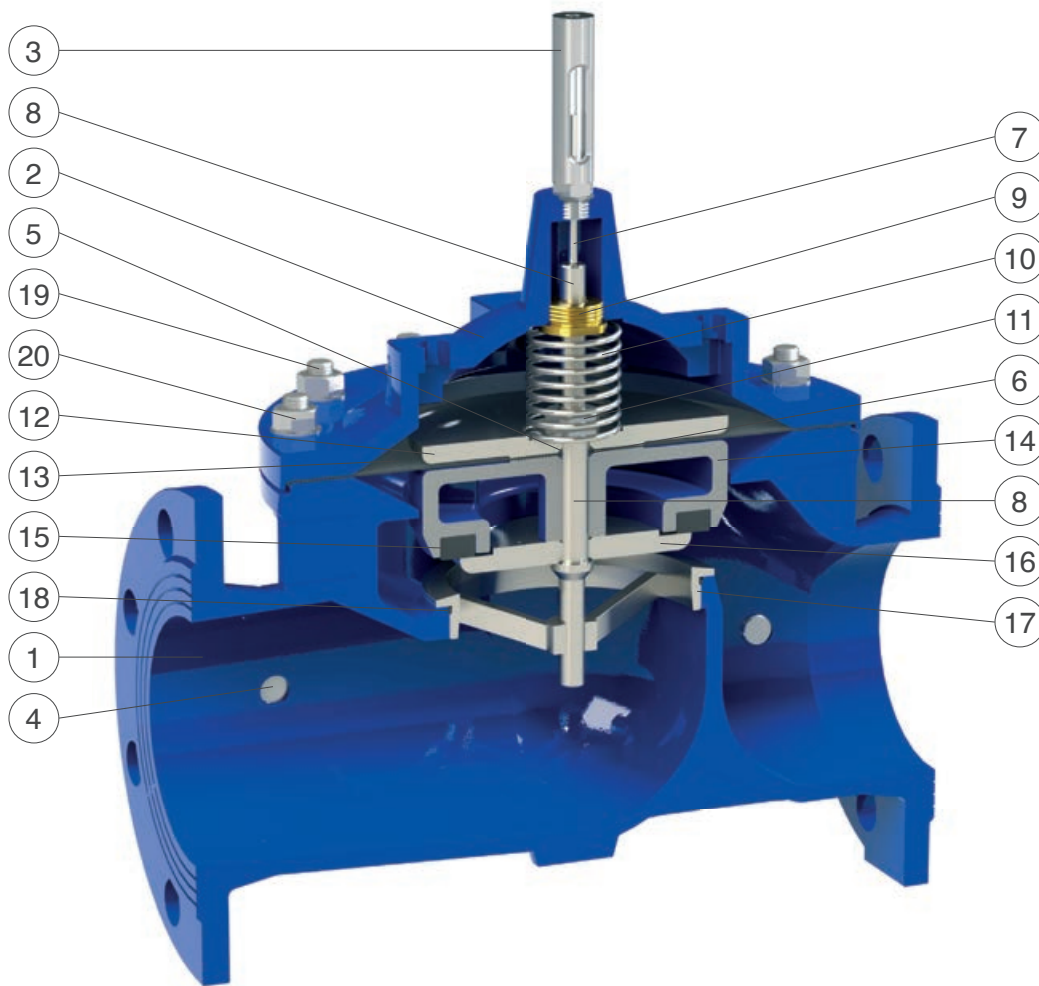

N.	Component	Standard material	Optional
1	Body	ductile cast iron GJS 450-10	
2	Cap	ductile cast iron GJS 450-10	
3	Position indicator	s.s. AISI 303	stainless steel AISI 316
4	Pressure outlet taps	stainless steel AISI 316	
5	Upper flat O-ring	NBR	EPDM/Viton
6	Obturator O-ring	NBR	EPDM/Viton
7	Indicator stem	stainless steel AISI 303	stainless steel AISI 316
8	Main shaft	stainless steel AISI 303	stainless steel AISI 316
9	Guide ring	bronze CuSn5Zn5Pb5	stainless s. AISI 304/316
10	Spring	stainless steel AISI 302	
11	Locking nut	stainless steel AISI 304	stainless steel AISI 316
12	Upper flat	painted steel	stainless s. AISI 304/316
13	Diaphragm	EPDM-Nylon	neoprene
14	Obturator	P. steel (DN50 - 100), duct. c. iron (from DN 150)	stainless s. AISI 304/316
15	Plane gasket	EPDM	
16	Gasket holder	stainless steel AISI 303 (304 from DN 150)	stainless steel AISI 316
17	Seat	stainless steel AISI 303 (316 from DN 150)	stainless steel AISI 316
18	Seat O-ring	NBR	EPDM/Viton
19	Studs	stainless steel AISI 304	stainless steel AISI 316
20	Nuts and washers	stainless steel AISI 304	stainless steel AISI 316

The list of materials and components is subject to changes without notice.



## H-VAL 400 - Standard version - Technical data

DN (mm)	40	50	65	80	100	150	200	250	300	400	600
Kv (m <sup>3</sup> /h)	40,6	40,6	68	126	169	410	662	1126	1504	2675	5544
Stroke (mm)	15	15	18	21	27	43	56	70	84	110	162

### Head loss coefficient

Kv coefficient representing the flow rate which is flowing through the valve fully open, and producing a head loss of 1 bar.

### Cavitation chart

The cavitation analysis is very important since it may lead to substantial damages, in addition to vibration and noise. The cavitation chart has to be used to determine whether the working point obtained by the intersection of the lines, connecting upstream (y axis) and downstream (x axis) pressure conditions, lies within one of the 3 zones to be identified as follows:

- A: Recommended working conditions;
- B: Noise cavitation;
- C: Damage cavitation.

The chart is to be used for valves modulating with an opening percentage between 35-40% at standard water temperature and elevation below 300 m. For continuous pressure reduction the maximum allowed  $\Delta p$  shall not exceed 15 bar.

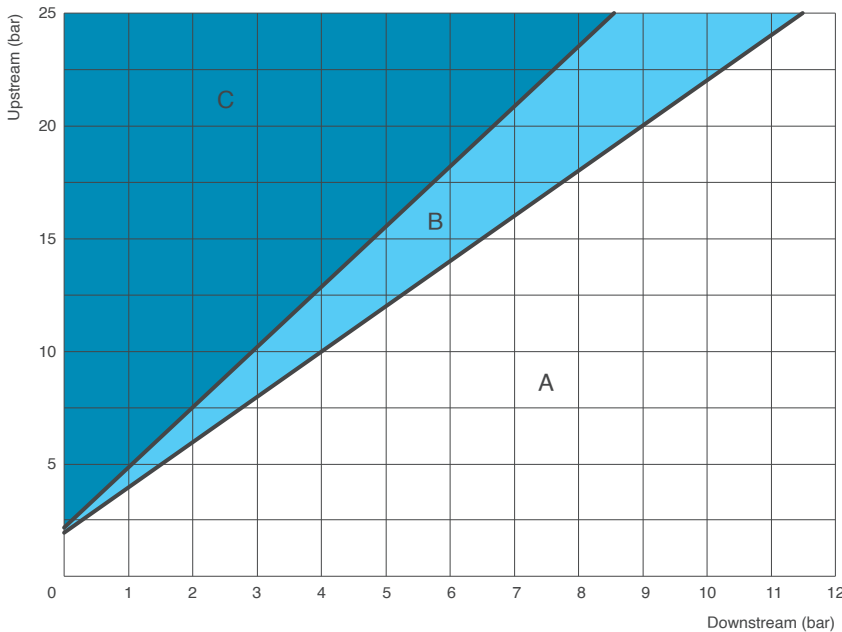

### Head loss chart

The chart indicates the head loss of H-VAL 400 automatic control valves fully open versus flow rate in l/s.

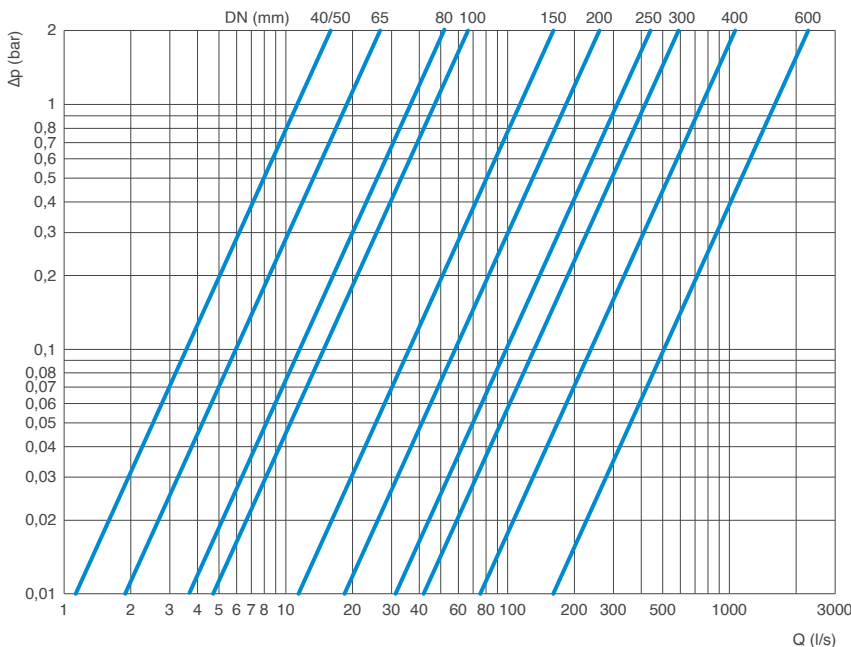

### Recommended flow rate

The following chart shows the recommended flow rate for the proper sizing of H-VAL 400 control valves.

DN (mm)		40/50	65	80	100	150	200	250	300	400	600	
Flow rate (l/s)	Recommended	Min.	1	1,7	2,5	3,9	8,8	16	25	35	63	132
		Max.	9,8	17	25	39	88	157	245	353	628	1413
	Pressure relief	Max.	15	25	38	59	132	235	368	530	942	1978

All values are approximate, consult PF service for more details.

## H-VAL 400 - AC version - Technical details

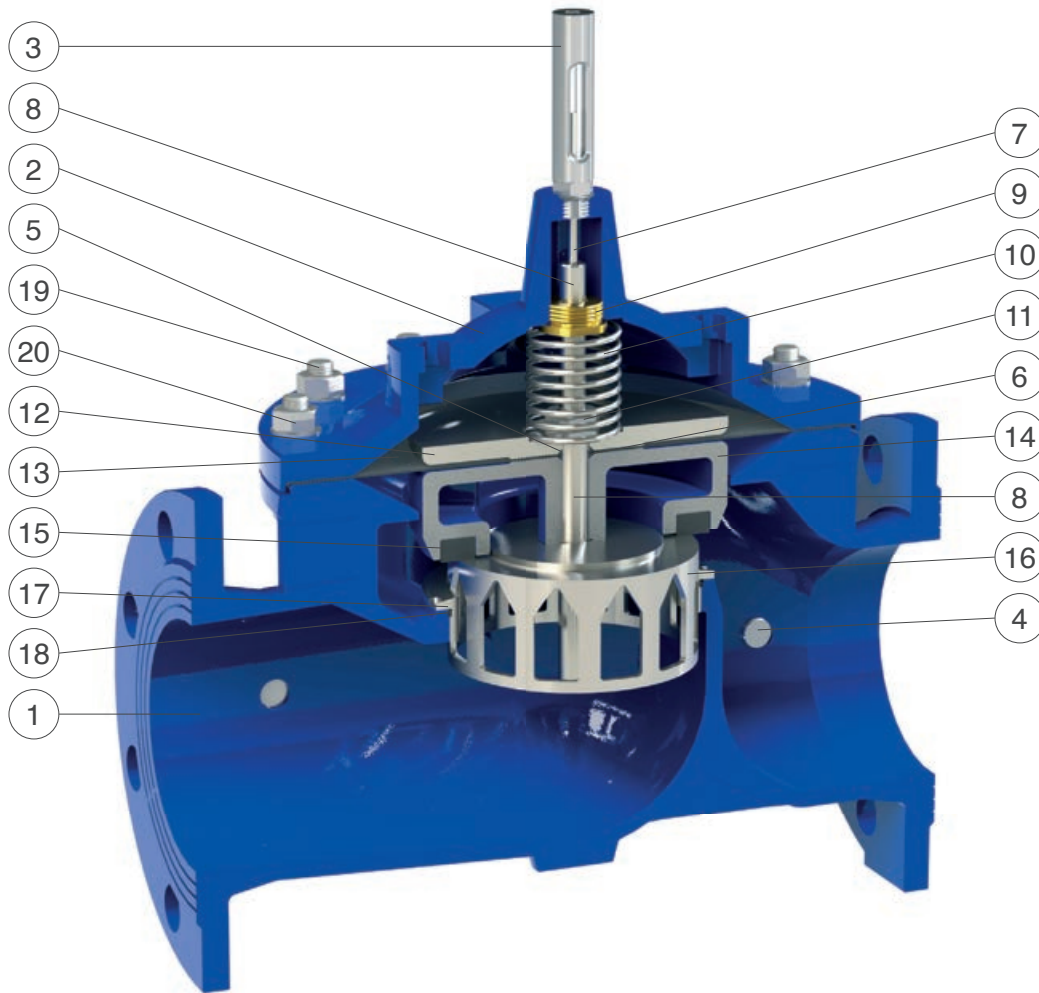

N.	Component	Standard material	Optional
1	Body	ductile cast iron GJS 450-10	
2	Cap	ductile cast iron GJS 450-10	
3	Position indicator	s.s. AISI 303	
4	Pressure outlet taps	stainless steel AISI 316	
5	Upper flat O-ring	NBR	EPDM/Viton
6	Obturator O-ring	NBR	EPDM/Viton
7	Indicator stem	stainless steel AISI 303	stainless steel AISI 316
8	Main shaft	stainless steel AISI 303	stainless steel AISI 316
9	Guide ring	bronze CuSn5Zn5Pb5	stainless s. AISI 304/316
10	Spring	stainless steel AISI 302	
11	Locking nut	stainless steel AISI 304	stainless steel AISI 316
12	Upper flat	painted steel	stainless s. AISI 304/316
13	Diaphragm	EPDM-Nylon	neoprene
14	Obturator	P.steel (DN50 - 100), duct. c. iron (from DN 150)	stainless s. AISI 304/316
15	Plane gasket	EPDM	
16	V-port	stainless steel AISI 303 (304 from DN 150)	stainless steel AISI 316
17	Seat for system AC	stainless steel AISI 303 (316 from DN 150)	stainless steel AISI 316
18	Seat O-ring	NBR	EPDM/Viton
19	Studs	stainless steel AISI 304	stainless steel AISI 316
20	Nuts and washers	stainless steel AISI 304	stainless steel AISI 316

The list of materials and components is subject to changes without notice.

## H-VAL 400 - AC version - Technical data

DN (mm)	40	50	65	80	100	150	200	250	300	400	600
Kv (m <sup>3</sup> /h)	32,5	32,5	56	100	132	312	523	867	1173	2113	4158
Stroke (mm)	15	15	18	21	27	43	56	70	84	110	162

### Head loss coefficient

Kv coefficient representing the flow rate which is flowing through the valve fully open, and producing a head loss of 1 bar.

### Cavitation chart

The cavitation analysis is very important since it may lead to substantial damages, in addition to vibration and noise. The cavitation chart has to be used to determine whether the working point obtained by the intersection of the lines, connecting upstream (y axis) and downstream (x axis) pressure conditions, lies within one of the 3 zones to be identified as follows:

- A: Recommended working conditions;
- B: Noise cavitation;
- C: Damage cavitation.

The chart is to be used for valves modulating with an opening percentage between 35-40% at standard water temperature and elevation below 300 m. For continuous pressure reduction the maximum allowed  $\Delta p$  shall not exceed 15 bar.

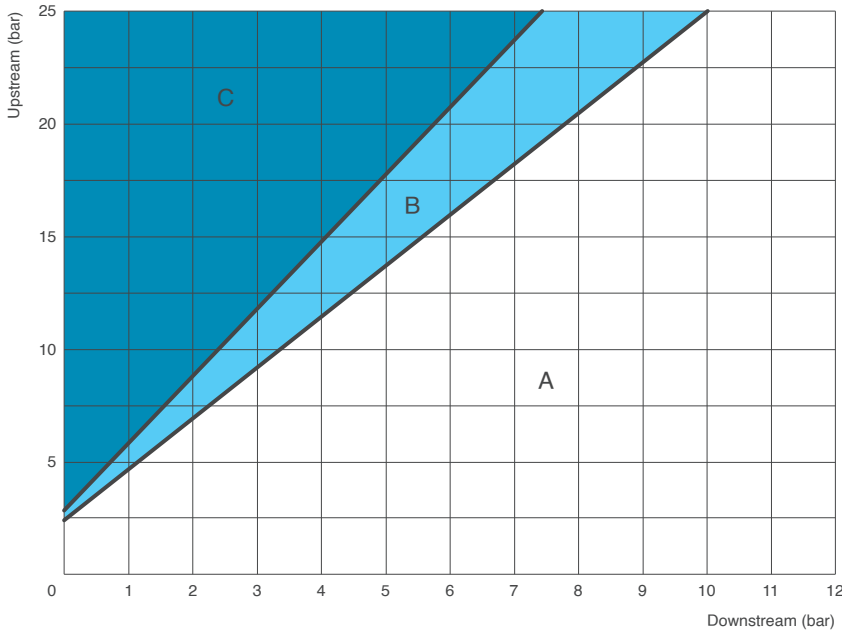

### Head loss chart

The chart indicates the head loss of H-VAL 400-AC automatic control valves fully open versus flow rate in l/s.

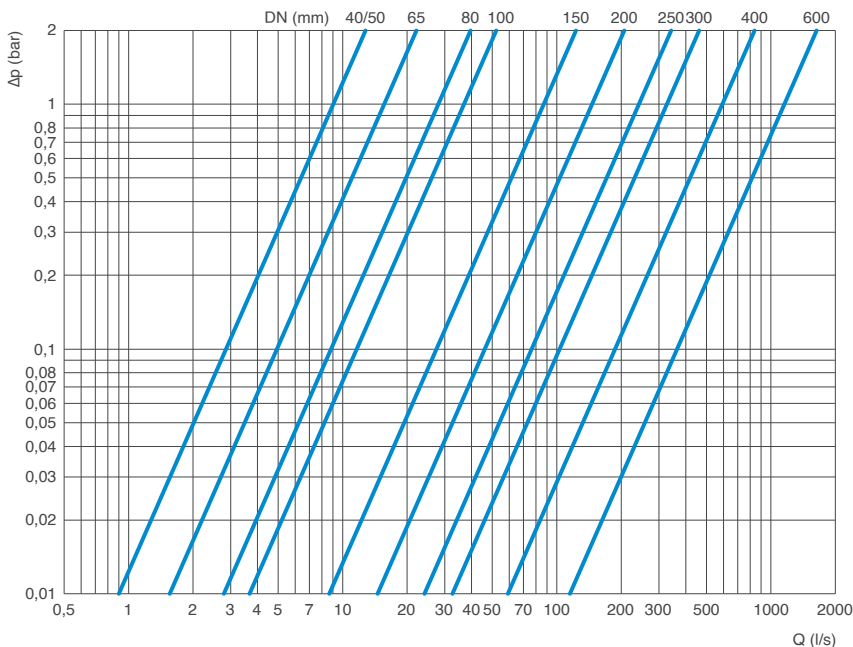

### Recommended flow rate

The following chart shows the recommended flow rate for the proper sizing of H-VAL 400-AC control valves.

DN (mm)		40/50	65	80	100	150	200	250	300	400	600	
Flow rate (l/s)	Recommended	Min.	0,5	0,9	1,4	2,2	4,9	8,8	14	20	35	71
		Max.	7,9	14	19	30	67	124	188	274	496	1130
	Pressure relief	Max.	12	20	30	46	100	185	283	412	744	1582

The technical informations are indicative and can change according to the number and dimension of the slots.

## H-VAL 400 - CP anti-cavitation version - Technical details

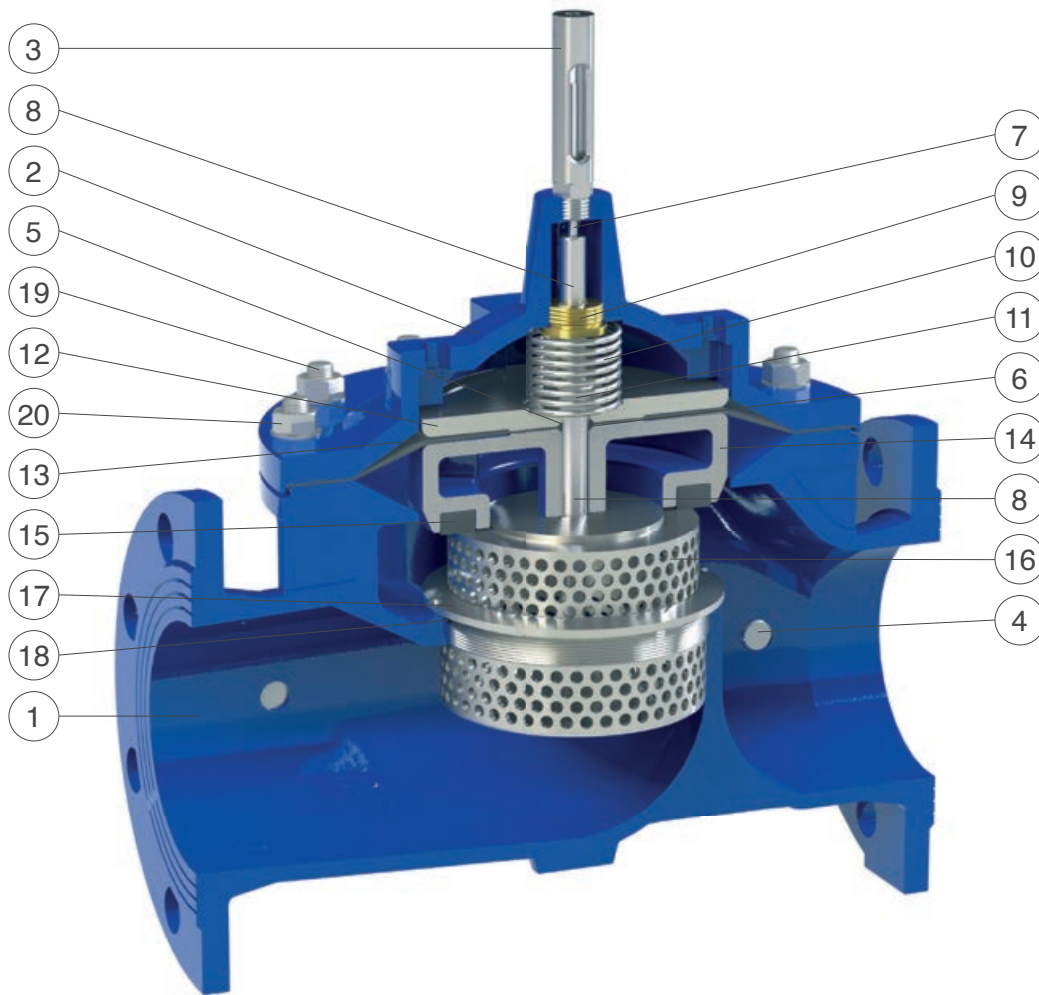

N.	Component	Standard material	Optional
1	Body	ductile cast iron GJS 450-10	
2	Cap	ductile cast iron GJS 450-10	
3	Position indicator	s.s. AISI 303	
4	Pressure outlet taps	stainless steel AISI 316	
5	Upper flat O-ring	NBR	EPDM/Viton
6	Obturator O-ring	NBR	EPDM/Viton
7	Indicator stem	stainless steel AISI 303	stainless steel AISI 316
8	Main shaft	stainless steel AISI 303	stainless steel AISI 316
9	Guide ring	bronze CuSn5Zn5Pb5	stainless s. AISI 304/316
10	Spring	stainless steel AISI 302	
11	Locking nut	stainless steel AISI 304	stainless steel AISI 316
12	Upper flat	painted steel	stainless s. AISI 304/316
13	Diaphragm	EPDM-Nylon	neoprene
14	Obturator	P.steel (DN 50 - 100), duct. c. iron (from DN 150)	stainless s. AISI 304/316
15	Plane gasket	EPDM	NBR
16	Anti-cavitation gasket holder CP	stainless steel AISI 303 (304 from DN 150)	stainless steel AISI 316
17	Seat for anti-cavitation system CP	stainless steel AISI 303 (316 from DN 150)	stainless steel AISI 316
18	Seat O-ring	NBR	EPDM/Viton
19	Studs	stainless steel AISI 304	stainless steel AISI 316
20	Nuts and washers	stainless steel AISI 304	stainless steel AISI 316

The list of materials and components is subject to changes without notice.



## H-VAL 400 - CP anti-cavitation version - Technical data

DN (mm)	40	50	65	80	100	150	200	250	300	400	600
Kv (m <sup>3</sup> /h)	20	20	34	63	84	205	331	563	752	1337	2520
Stroke (mm)	15	15	18	21	27	43	56	70	84	110	162

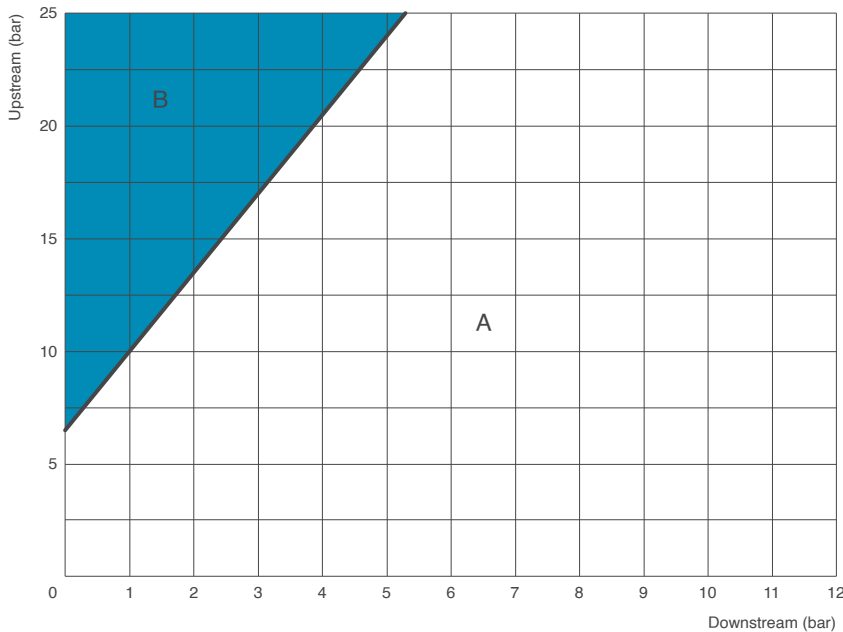

### Head loss coefficient

Kv coefficient representing the flow rate which is flowing through the valve fully open, and producing a head loss of 1 bar.

### Cavitation chart

The cavitation analysis is very important since it may lead to substantial damages, in addition to vibration and noise. The cavitation chart has to be used to determine whether the working point obtained by the intersection of the lines, connecting upstream (y axis) and downstream (x axis) pressure conditions, lies within one of the two zones to be identified as follows:

- A: Recommended working conditions;
- B: Damage cavitation.

The chart is to be used for valves modulating with an opening percentage between 35-40% at standard water temperature and elevation below 300 m. For continuous pressure reduction the maximum allowed  $\Delta p$  shall not exceed 15 bar.

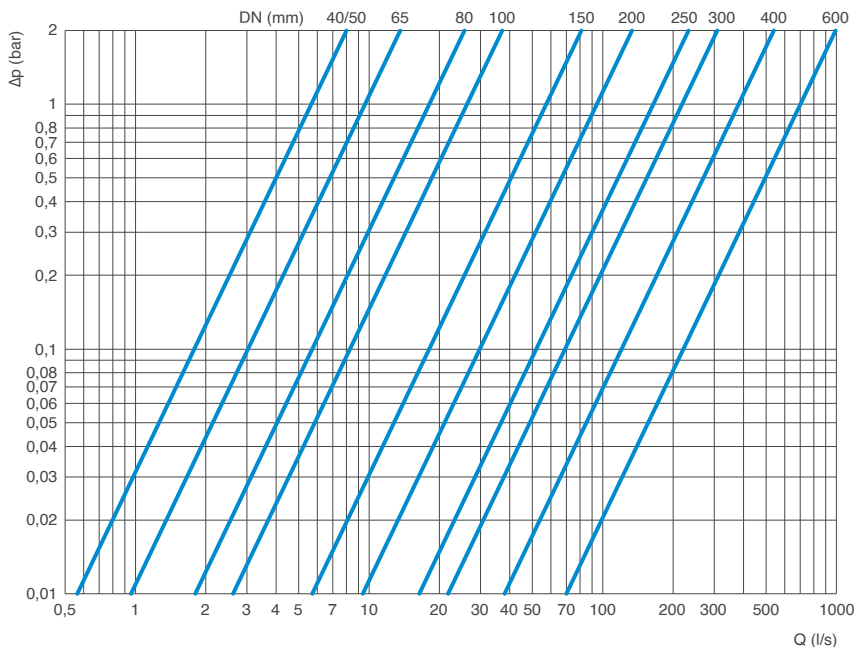

### Head loss chart

The chart indicates the head loss of H-VAL 400-CP automatic control valves fully open versus flow rate in l/s.

### Recommended flow rate

The following chart shows the recommended flow rate for the proper sizing of H-VAL 400-CP control valves.

DN (mm)		40/50	65	80	100	150	200	250	300	400	600	
Flow rate (l/s)	Recommended	Min.	0,4	0,7	1,0	1,6	3,5	6,3	9,8	14	25	57
		Max.	3,9	6,6	9,7	16	40	64	109	146	260	635
	Pressure relief	Max.	9,8	16	25	39	88	157	245	353	628	989

The technical informations are indicative and can change according to the number and dimension of the holes.

## H-VAL 400 - Standard and anti-cavitation versions - Technical data

### Kv to valve opening chart

The following chart shows the opening percentage of H-VAL 400, XLC 400-AC and H-VAL 400-CP versus the Kv.

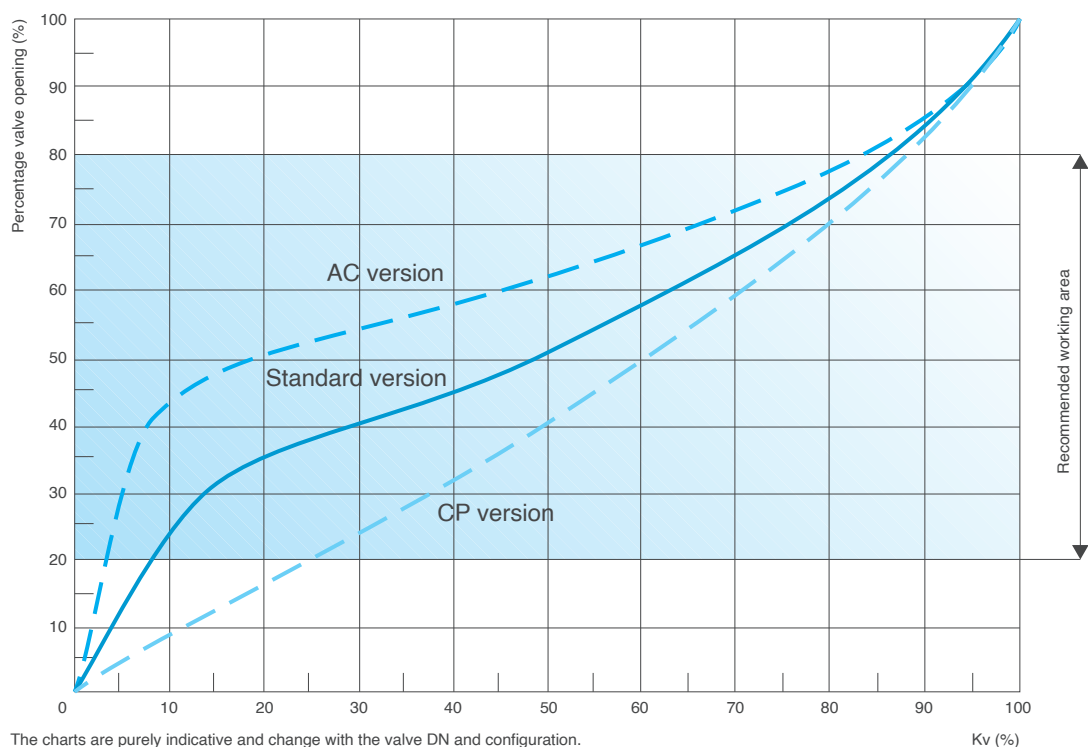

The charts are purely indicative and change with the valve DN and configuration.

Kv (%)

### Working conditions

Treated filtered water.

Maximum temperature: 70°C.

Minimum pressure on the pilot : 0,5 bar plus head loss.

Maximum pressure : 25 bar.

### Standard

Certified and tested in compliance with EN 1074/5.

Pressure rating 25 bar.

Flanges according to EN 1092/2 (different drilling on request).

Epoxy painting applied through FBT technology blue RAL 5005.

### Weights and dimensions

DN (mm)	A (mm)	B (mm)	C (mm)	D (mm)	E (mm)	Weight (Kg)
40	230	162	83	235	30	18
50	230	162	83	235	30	18
65	290	194	93	275	30	23,5
80	310	218	100	295	30	28
100	350	260	118	335	30	39
150	480	370	150	450	30	84
200	600	444	180	495	30	138
250	730	570	213	600	40	264
300	850	676	242	720	40	405
400	1100	870	310	915	40	704
600	1450	1230	433	1080*	40	2250

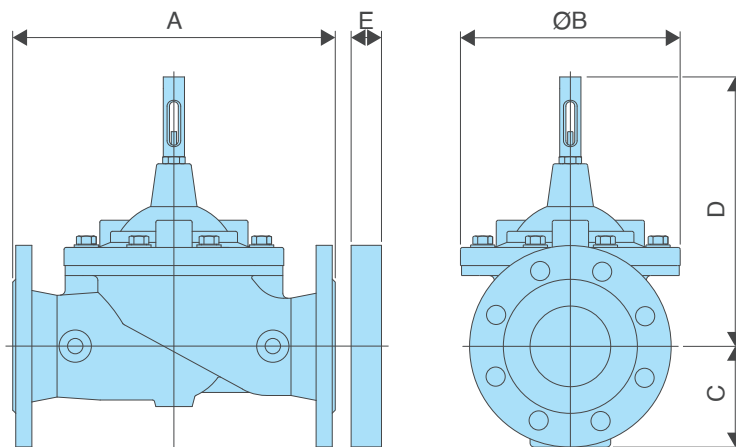

The dimension E in the picture above refers only to applications where it is necessary to add a flanged orifice downstream or upstream of the valve, for example for flow control or cavitation prevention.

\*: Height without position indicator.

All values are approximate, consult PF service for more details.

## H-VAL 400 - Standard and anti-cavitation versions - Spare parts breakdown

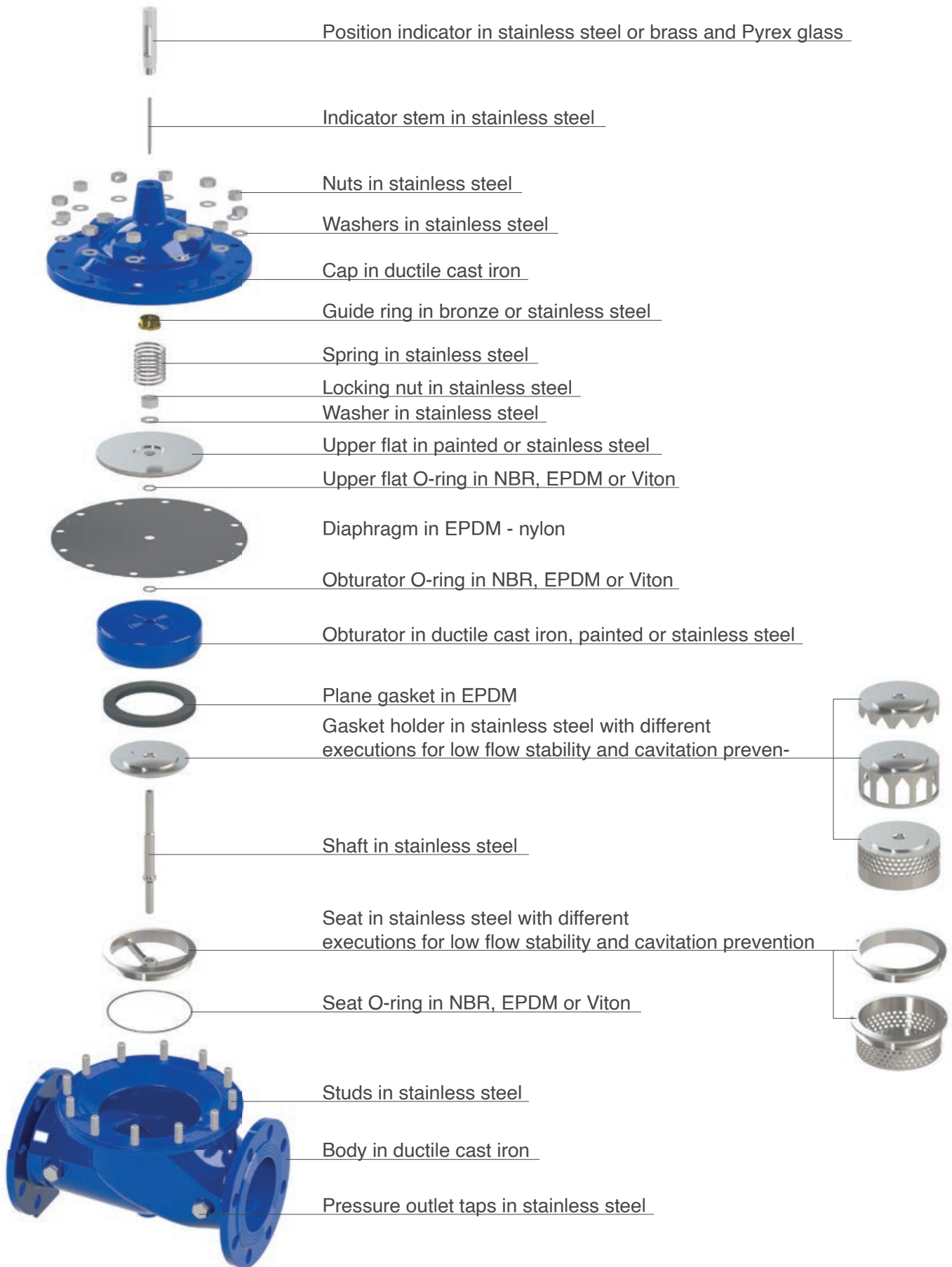

## H-VAL 300 - Standard version - Technical details

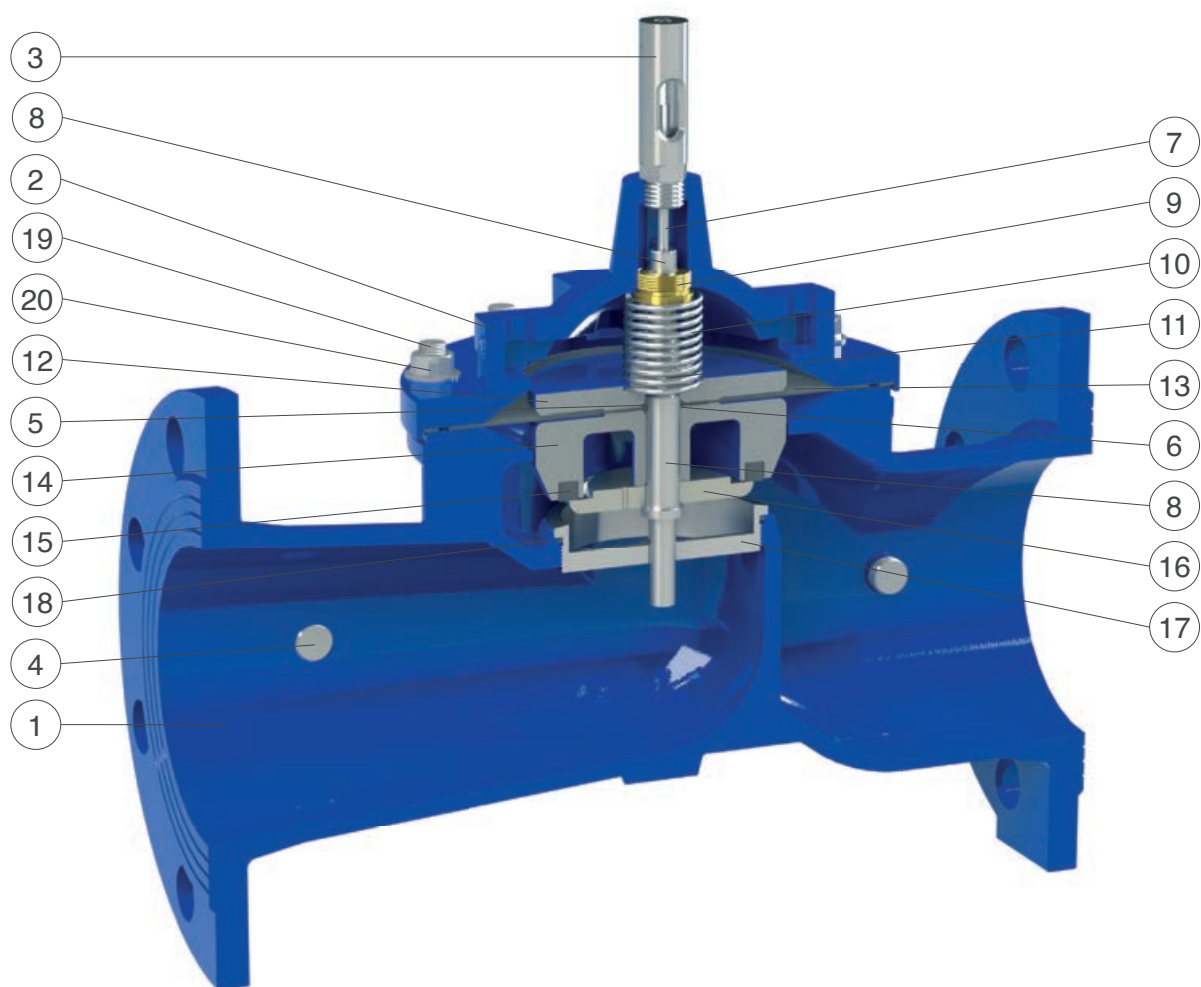

N.	Component	Standard material	Optional
1	Body	ductile cast iron GJS 450-10	
2	Cap	ductile cast iron GJS 450-10	
3	Position indicator	s.s. AISI 303	
4	Pressure outlet taps	stainless steel AISI 316	
5	Upper flat O-ring	NBR	EPDM/Viton
6	Obturator O-ring	NBR	EPDM/Viton
7	Indicator stem	stainless steel AISI 303	stainless steel AISI 316
8	Main shaft	stainless steel AISI 303	stainless steel AISI 316
9	Guide ring	bronze CuSn5Zn5Pb5	stainless s. AISI 304/316
10	Spring	stainless steel AISI 302	
11	Locking nut	stainless steel AISI 304	stainless steel AISI 316
12	Upper flat	painted steel	stainless s. AISI 304/316
13	Diaphragm	EPDM-Nylon	neoprene
14	Obturator	p. steel(DN 80 - 150) , duct. c. iron (from DN 200)	stainless s. AISI 304/316
15	Plane gasket	EPDM	NBR
16	Gasket holder	stainless steel AISI 303 (304 from DN 200)	stainless steel AISI 316
17	Seat	stainless steel AISI 303 (316 from DN 200)	stainless steel AISI 316
18	Seat O-ring	NBR	EPDM/Viton
19	Studs	stainless steel AISI 304	stainless steel AISI 316
20	Nuts and washers	stainless steel AISI 304	stainless steel AISI 316

The list of materials and components is subject to changes without notice.



## H-VAL 300 - Standard version - Technical data

DN (mm)	80	100	125	150	200	250	300	400	500	600	800
Kv (m <sup>3</sup> /h)	54	141	187	198	487	802	1256	1742	3089	3236	6706
Stroke (mm)	15	21	27	27	43	56	70	84	110	110	162

### Head loss coefficient

Kv coefficient representing the flow rate which is flowing through the valve fully open, and producing a head loss of 1 bar.

### Cavitation chart

The cavitation analysis is very important since it may lead to substantial damages, in addition to vibration and noise. The cavitation chart has to be used to determine whether the working point obtained by the intersection of the lines, connecting upstream (y axis) and downstream (x axis) pressure conditions, lies within one of the 3 zones to be identified as follows:

- A: Recommended working conditions;
- B: Noise cavitation;
- C: Damage cavitation.

The chart is to be used for valves modulating with an opening percentage between 35-40% at standard water temperature and elevation below 300 m. For continuous pressure reduction the maximum allowed  $\Delta p$  shall not exceed 15 bar.

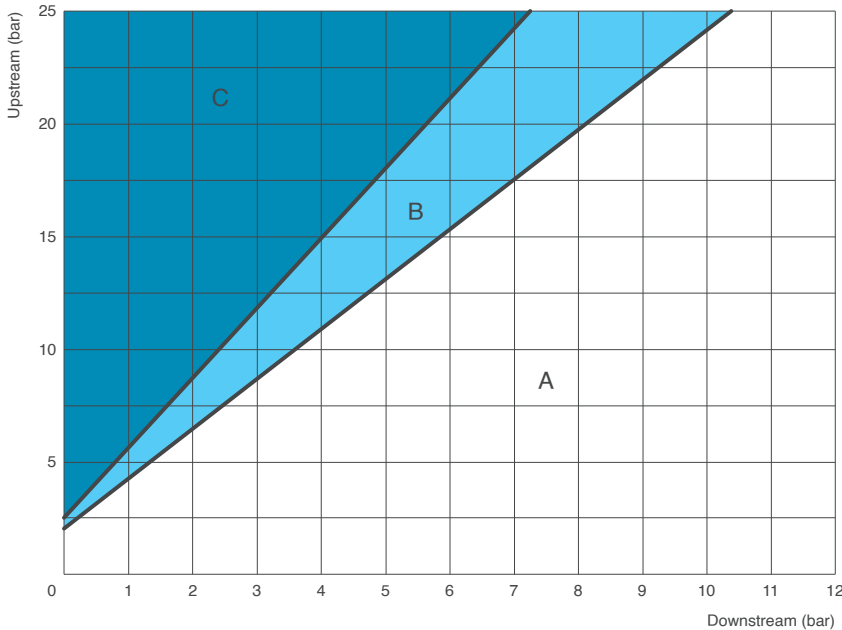

### Head loss chart

The chart indicates the head loss of H-VAL 300 automatic control valves fully open versus flow rate in l/s.

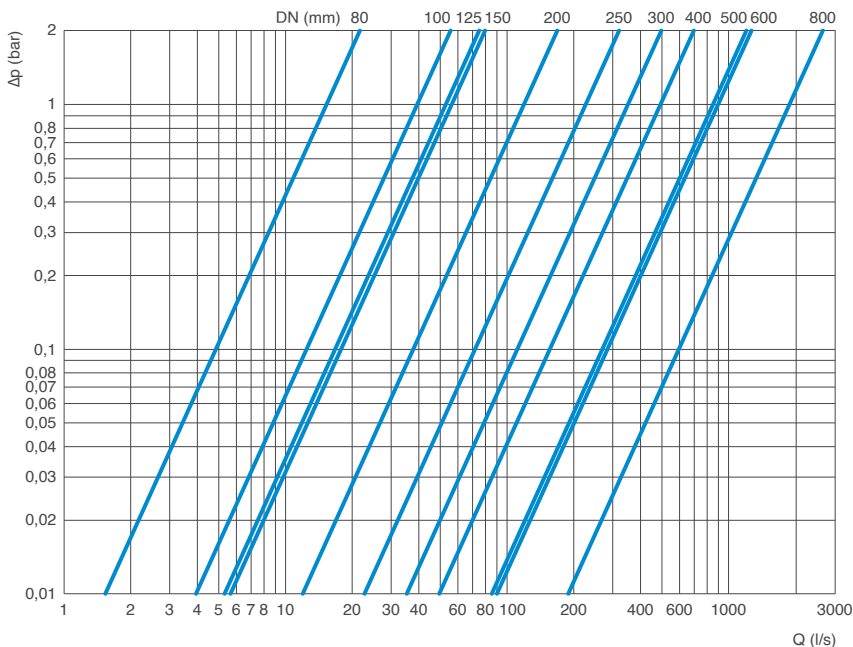

### Recommended flow rate

The following chart shows the recommended flow rate for the proper sizing of H-VAL 300 control valves.

DN (mm)		80	100	125	150	200	250	300	400	500	600	800	
Flow rate (l/s)	Recommended	Min.	1,0	2,5	3,9	4,1	8,8	16	25	35	63	82	144
		Max.	11	29	43	45	101	180	274	406	695	728	1638
	Pressure relief	Max.	15	38	59	62	132	235	368	530	942	1080	1978

All values are approximate, consult PF service for more details.

## H-VAL 300 - AC version - Technical details

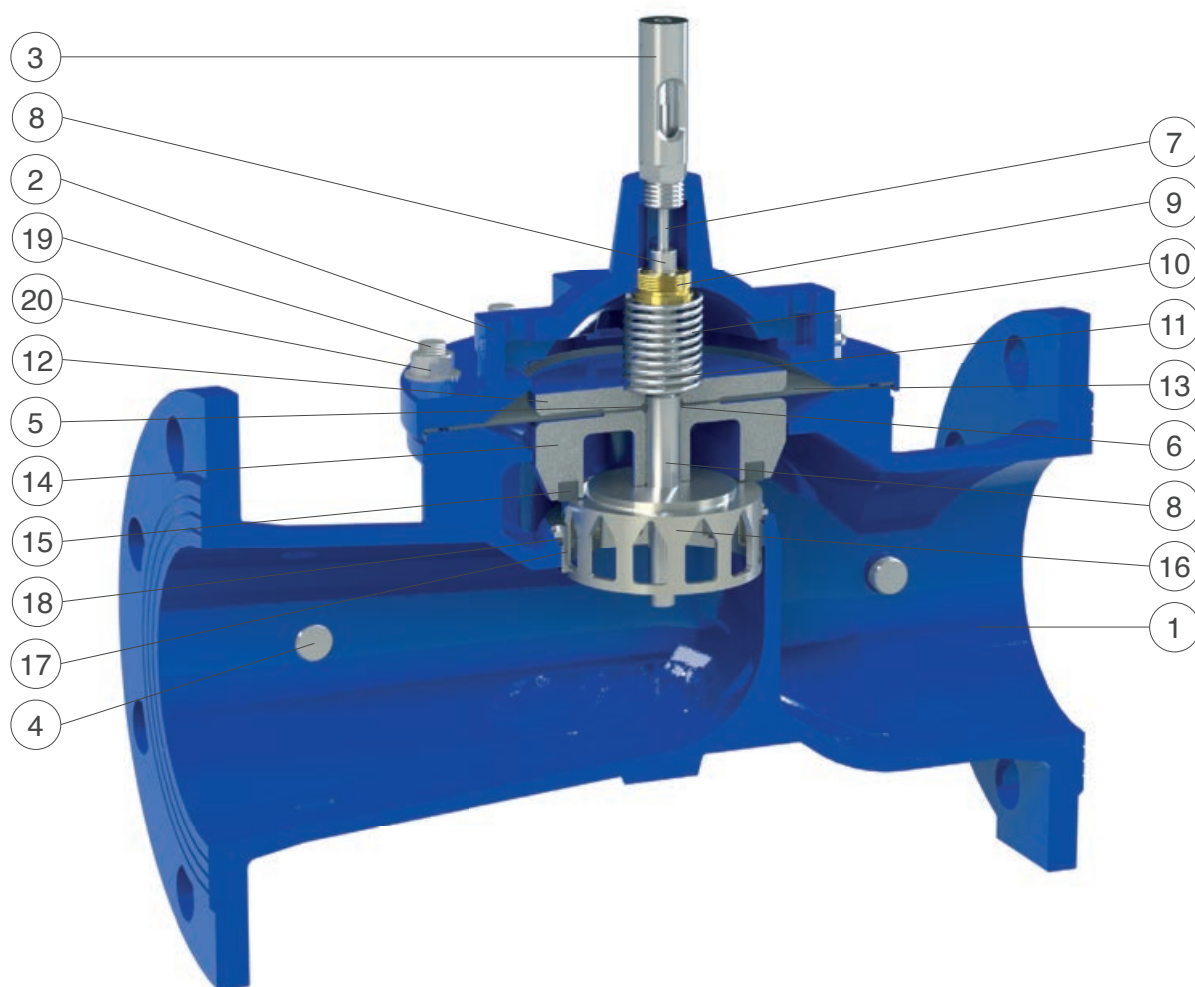

N.	Component	Standard material	Optional
1	Body	ductile cast iron GJS 450-10	
2	Cap	ductile cast iron GJS 450-10	
3	Position indicator	s.s. AISI 303	
4	Pressure outlet taps	stainless steel AISI 316	
5	Upper flat O-ring	NBR	EPDM/Viton
6	Obturator O-ring	NBR	EPDM/Viton
7	Indicator stem	stainless steel AISI 303	stainless steel AISI 316
8	Main shaft	stainless steel AISI 303	stainless steel AISI 316
9	Guide ring	bronze CuSn5Zn5Pb5	stainless s. AISI 304/316
10	Spring	stainless steel AISI 302	
11	Locking nut	stainless steel AISI 304	stainless steel AISI 316
12	Upper flat	painted steel	stainless s. AISI 304/316
13	Diaphragm	EPDM-Nylon	neoprene
14	Obturator	p. steel (DN 80 - 150), duct. c. iron (from DN 200)	stainless s. AISI 304/316
15	Plane gasket	EPDM	
16	V-port	stainless steel AISI 303 (304 from DN 200)	stainless steel AISI 316
17	Seat for system AC	stainless steel AISI 303 (316 from DN 200)	stainless steel AISI 316
18	Seat O-ring	NBR	EPDM/Viton
19	Studs	stainless steel AISI 304	stainless steel AISI 316
20	Nuts and washers	stainless steel AISI 304	stainless steel AISI 316

The list of materials and components is subject to changes without notice.

## H-VAL 300 - AC version - Technical data

DN (mm)	80	100	125	150	200	250	300	400	500	600	800
Kv (m <sup>3</sup> /h)	43	111	146	154	377	633	967	1356	2409	2588	5092
Stroke (mm)	15	21	27	27	43	56	70	84	110	110	162

### Head loss coefficient

Kv coefficient representing the flow rate which is flowing through the valve fully open, and producing a head loss of 1 bar.

### Cavitation chart

The cavitation analysis is very important since it may lead to substantial damages, in addition to vibration and noise. The cavitation chart has to be used to determine whether the working point obtained by the intersection of the lines, connecting upstream (y axis) and downstream (x axis) pressure conditions, lies within one of the 3 zones to be identified as follows:

- A: Recommended working conditions;
- B: Noise cavitation;
- C: Damage cavitation.

The chart is to be used for valves modulating with an opening percentage between 35-40% at standard water temperature and elevation below 300 m. For continuous pressure reduction the maximum allowed  $\Delta p$  shall not exceed 15 bar.

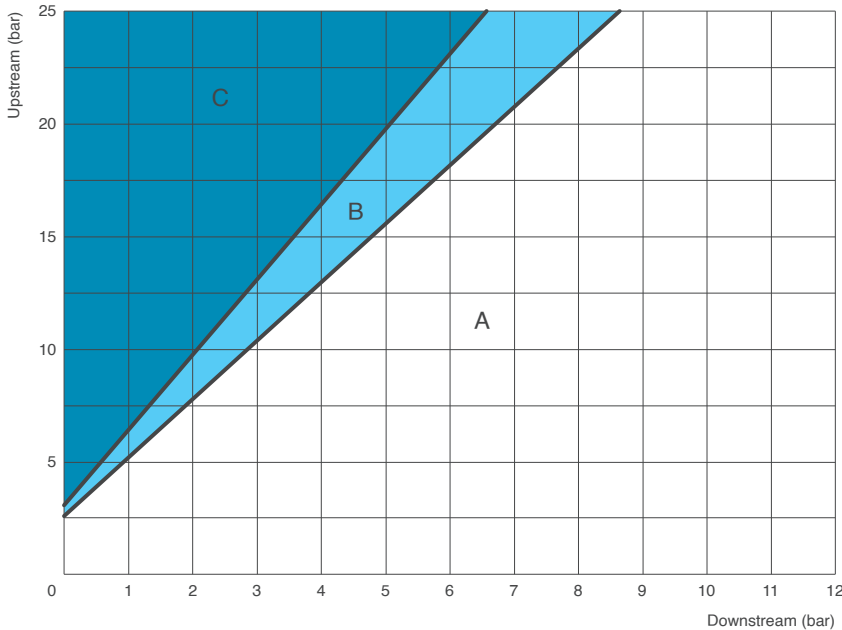

### Head loss chart

The chart indicates the head loss of H-VAL 300-AC automatic control valves fully open versus flow rate in l/s.

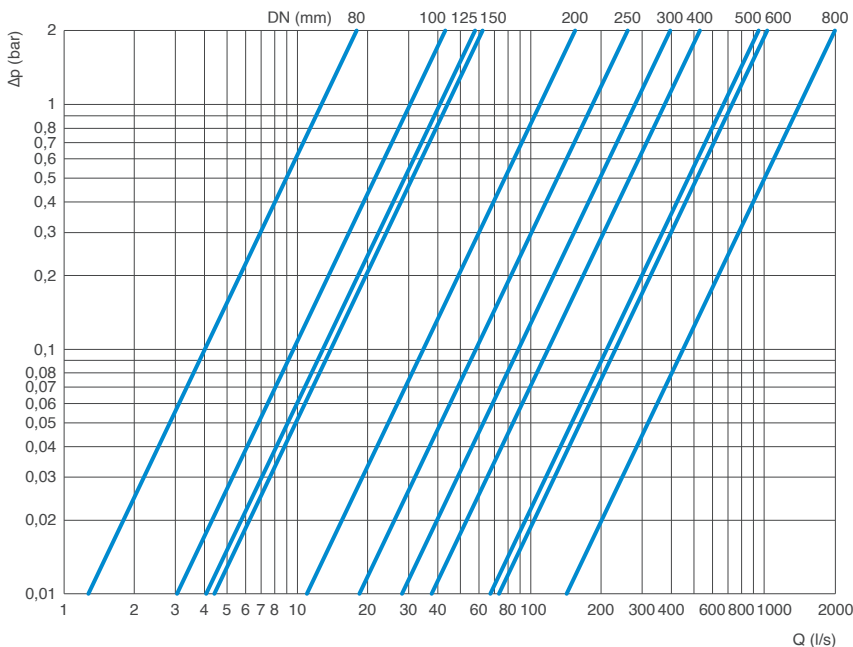

### Recommended flow rate

The following chart shows the recommended flow rate for the proper sizing of H-VAL 300-AC control valves.

DN (mm)		80	100	125	150	200	250	300	400	500	600	800	
Flow rate (l/s)	Recommended	Min.	0,5	1,4	2,2	2,3	4,9	8,8	14	20	35	44	71
		Max.	8,8	23	33	35	78	142	211	316	542	582	1325
	Pressure relief	Max.	12	30	46	48	102	185	283	412	734	753	1600

The technical informations are indicative and can change according to the number and dimension of the slots.

## H-VAL 300 - CP anti-cavitation version - Technical details

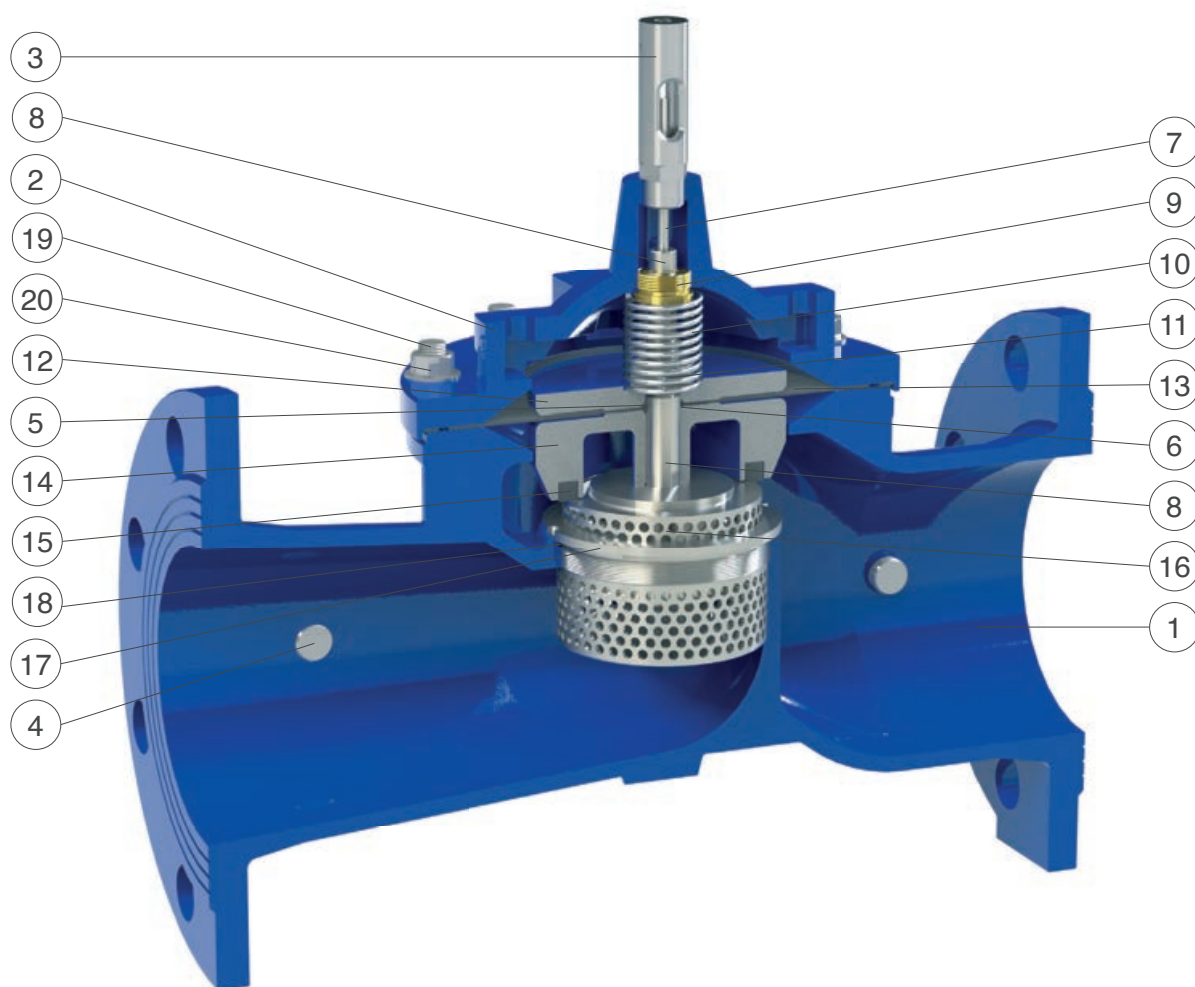

N.	Component	Standard material	Optional
1	Body	ductile cast iron GJS 450-10	
2	Cap	ductile cast iron GJS 450-10	
3	Position indicator	s.s. AISI 303	
4	Pressure outlet taps	stainless steel AISI 316	
5	Upper flat O-ring	NBR	EPDM/Viton
6	Obturator O-ring	NBR	EPDM/Viton
7	Indicator stem	stainless steel AISI 303	stainless steel AISI 316
8	Main shaft	stainless steel AISI 303	stainless steel AISI 316
9	Guide ring	bronze CuSn5Zn5Pb5	stainless s. AISI 304/316
10	Spring	stainless steel AISI 302	
11	Locking nut	stainless steel AISI 304	stainless steel AISI 316
12	Upper flat	painted steel	stainless s. AISI 304/316
13	Diaphragm	EPDM-Nylon	neoprene
14	Obturator	p. steel (DN 80 - 150), duct. c. iron (from DN 200)	stainless s. AISI 304/316
15	Plane gasket	EPDM	NBR
16	Anti-cavitation gasket holder CP	stainless steel AISI 303 (304 from DN 200)	stainless steel AISI 316
17	Seat for anti-cavitation system CP	stainless steel AISI 303 (316 from DN 200)	stainless steel AISI 316
18	Seat O-ring	NBR	EPDM/Viton
19	Studs	stainless steel AISI 304	stainless steel AISI 316
20	Nuts and washers	stainless steel AISI 304	stainless steel AISI 316

The list of materials and components is subject to changes without notice.



## H-VAL 300 - CP anti-cavitation version - Technical data

DN (mm)	80	100	125	150	200	250	300	400	500	600	800
Kv (m <sup>3</sup> /h)	24	63	72	89	207	361	565	783	1390	1456	2744
Stroke (mm)	15	21	27	27	43	56	70	84	110	110	162

### Head loss coefficient

Kv coefficient representing the flow rate which is flowing through the valve fully open, and producing a head loss of 1 bar.

### Cavitation chart

The cavitation analysis is very important since it may lead to substantial damages, in addition to vibration and noise. The cavitation chart has to be used to determine whether the working point obtained by the intersection of the lines, connecting upstream (y axis) and downstream (x axis) pressure conditions, lies within one of the two zones to be identified as follows:

- A: Recommended working conditions;
- B: Damage cavitation.

The chart is to be used for valves modulating with an opening percentage between 35-40% at standard water temperature and elevation below 300 m. For continuous pressure reduction the maximum allowed  $\Delta p$  shall not exceed 15 bar.

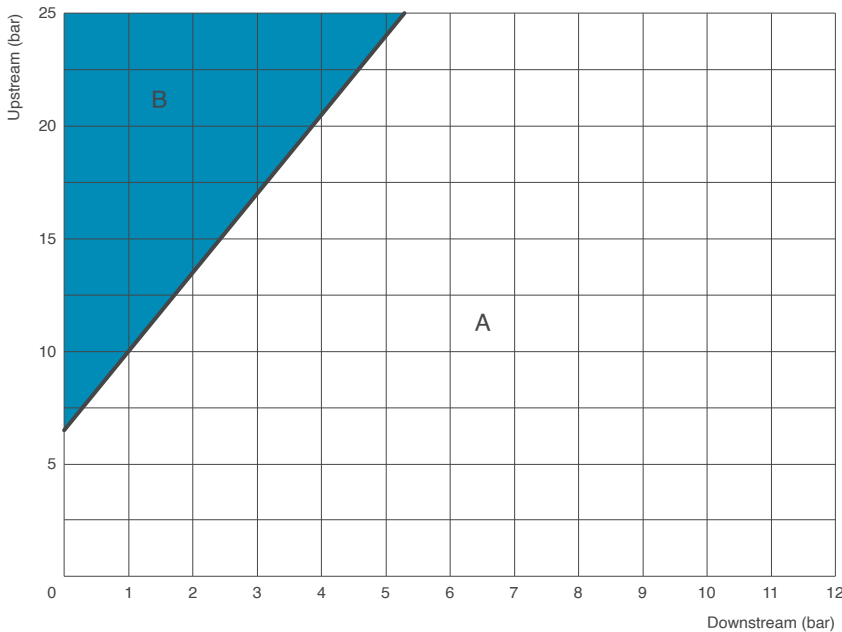

### Head loss chart

The chart indicates the head loss of H-VAL 300-CP automatic control valves fully open versus flow rate in l/s.

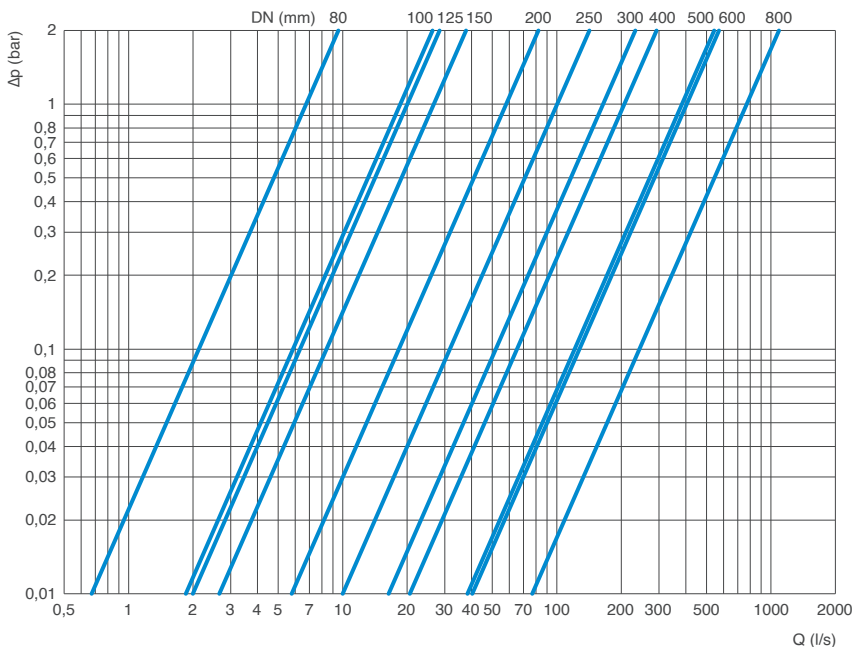

### Recommended flow rate

The following chart shows the recommended flow rate for the proper sizing of H-VAL 300-CP control valves.

DN (mm)			80	100	125	150	200	250	300	400	500	600	800
Flow rate (l/s)	Recommended	Min.	0,7	1,0	2,2	2,3	4,1	6,4	9,2	16	26	37	78
		Max.	5,1	11	16	18	43	75	118	163	289	303	740
	Pressure relief	Max.	11	25	40	42	98	170	267	370	656	688	1083

The technical informations are indicative and can change according to the number and dimension of the holes.

## H-VAL 300 - Standard and anti-cavitation versions - Technical data

### Kv to valve opening chart

The following chart shows the opening percentage of H-VAL 300, H-VAL 300-AC and H-VAL 300-CP versus the Kv.

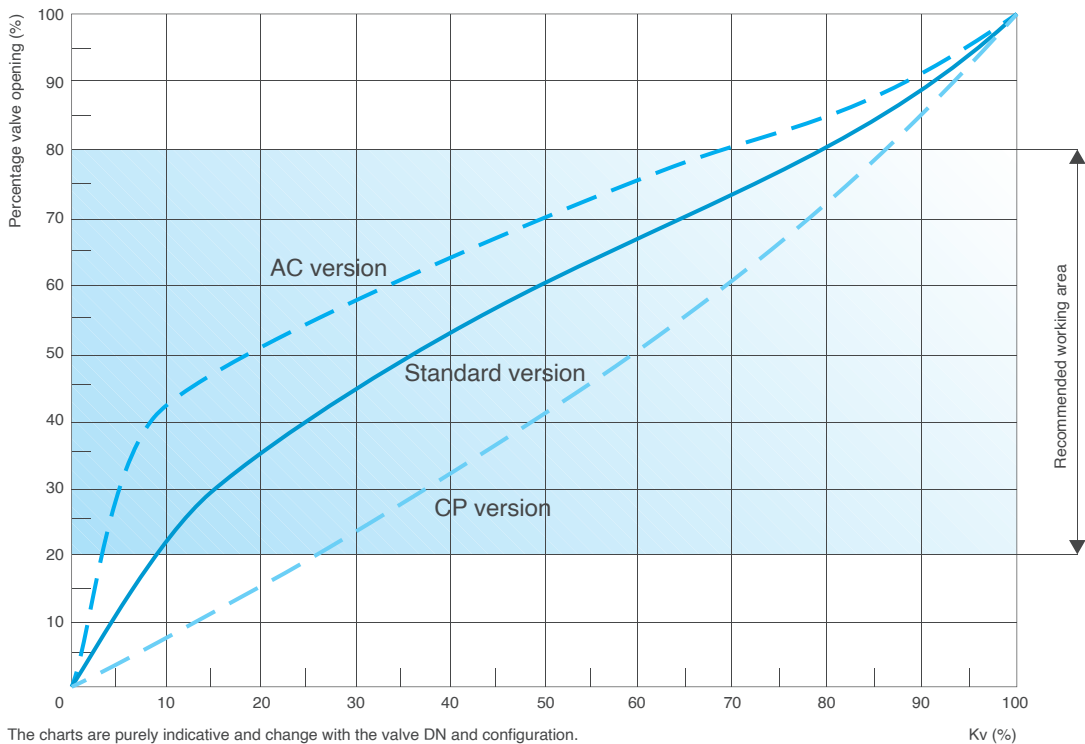

The charts are purely indicative and change with the valve DN and configuration.

Kv (%)

### Working conditions

Treated filtered water.  
 Maximum temperature: 70°C.  
 Minimum pressure on the pilot : 0,5 bar plus head loss.  
 Maximum pressure : 25 bar.

### Standard

Certified and tested in compliance with EN 1074/5.  
 Pressure rating 25 bar.  
 Flanges according to EN 1092/2 (different drilling on request).  
 Epoxy painting applied through FBT technology blue RAL 5005.

### Weights and dimensions

DN (mm)	A (mm)	B (mm)	C (mm)	D (mm)	E (mm)	Weight (Kg)
80	310	162	100	245	30	24
100	350	218	118	280	30	34
125	400	260	135	350	30	47
150	480	260	150	350	30	54
200	600	370	180	460	30	97
250	730	444	213	515	40	172
300	850	570	242	605	40	304
400	1100	680	310	745	40	480
500	1250	870	365	945	40	782
600	1450	870	423	970	40	922
800	1850	1230	543	1080*	50	2950

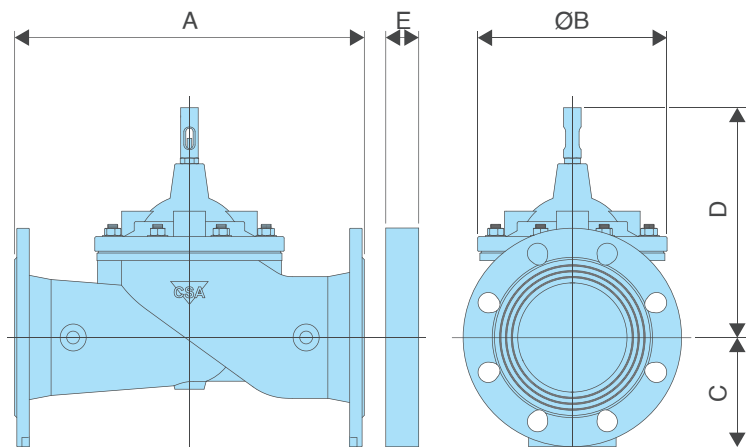

The dimension E in the picture above refers only to applications where it is necessary to add a flanged orifice downstream or upstream of the valve, for example for flow control or cavitation prevention.

\*: Height without position indicator.

All values are approximate, consult PF service for more details.

## H-VAL 300 - Standard and anti-cavitation versions - Spare parts breakdown



# Double chamber control valves H-VAL DC series

The PF H-VAL double chamber DC series, applicable for the full bore and reduced bore versions, consist of a globe pattern hydraulically operated automatic control valve. The intermediate chamber, in communication with the atmosphere or pressurized, separates the upper cover from the lower part with a diaphragm PN 25 bar class. The valve works with lower differential pressure with a faster response, both aspects extremely useful in special applications like pump control and proportional downstream pressure reduction. Low flow stability and anti-cavitation cages are available on request prior to sizing.



## Technical features

### Standard version of mobile block and sealing seat

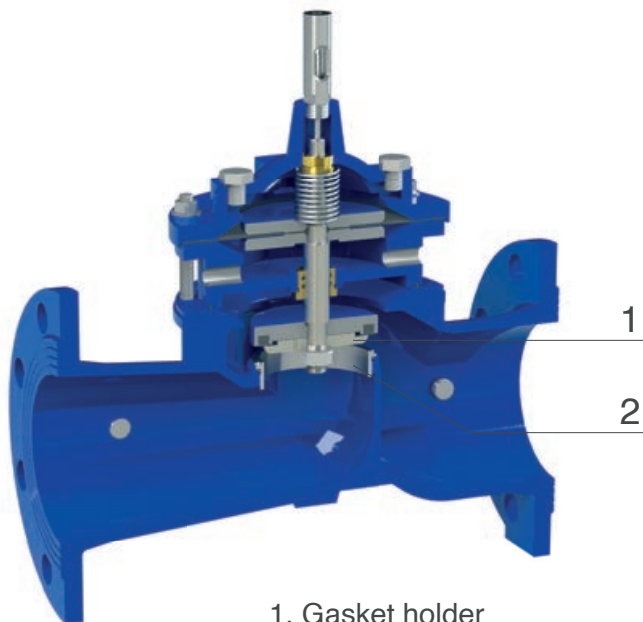

1. Gasket holder in stainless steel
2. Seat in stainless steel

### AC version for low flow stability and cavitation prevention

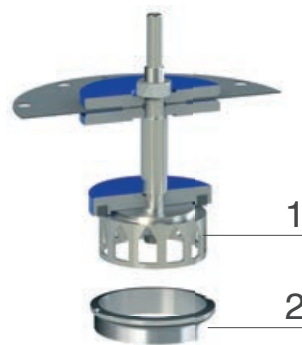

1. Gasket holder for low flow and cavitation prevention
2. Seat in stainless steel

### CP double cage anti-cavitation version

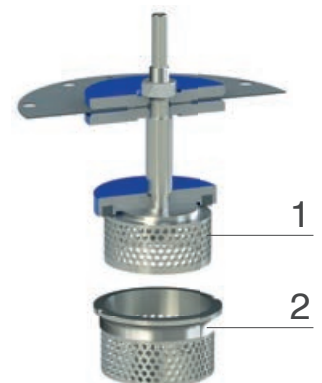

1. CP anti-cavitation gasket holder
2. CP anti-cavitation seat in stainless steel

The standard gasket holder guarantees the maximum accuracy also for low flow and small opening. The shaft of the mobile block is guided in two points, through the cover and the guide on the intermediate chamber, moving frictionless during modulation. The anti-cavitation trim AC mobile block includes a gasket holder designed to increase the allowable pressure ratio and resistance to cavitation, improving at the same time the valve's stability to guarantee the maximum accuracy also in case of no flow. The CP system includes two cages for double energy dissipation between inlet and outlet, obtained by the gasket holder and seat moving one inside the other, whose holes can be customized according to the project in hand and required performances, this is to avoid damages to the valve without a drastic reduction of the valve's Kv.



## Operating principle modulating mode - proportional pressure reduction

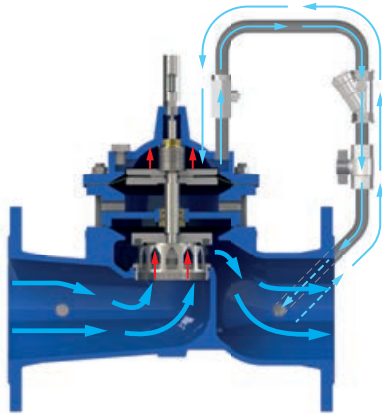

### Valve modulating

Due to the difference in surface between the upper flat of the control chamber and the obturator, the double chamber valve will keep modulating in case of water supply. That allows the regulation of the downstream value based on fixed ratio between inlet outlet, with the mobile block opening percentage changing according to the upstream pressure variations. The pressure ratio can be modified on request.

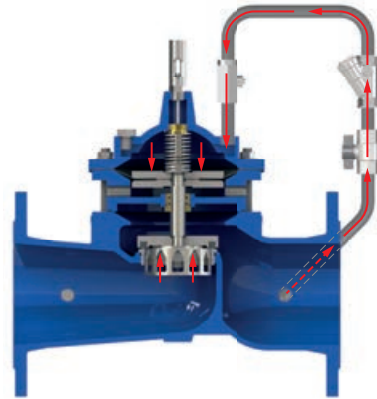

### Valve closed in static conditions

In case of static condition the downstream pressure is entirely applied on the upper control chamber through the hydraulic circuit (equipped with strainer and needle valve). That generates to different forces whose values are proportional to the surfaces, in particular the area of the diaphragm flat being wider than the one of the obturator causes a higher value pushing downwards with a drip tight closure of the valve.

## Operating principle on-off mode - remote control

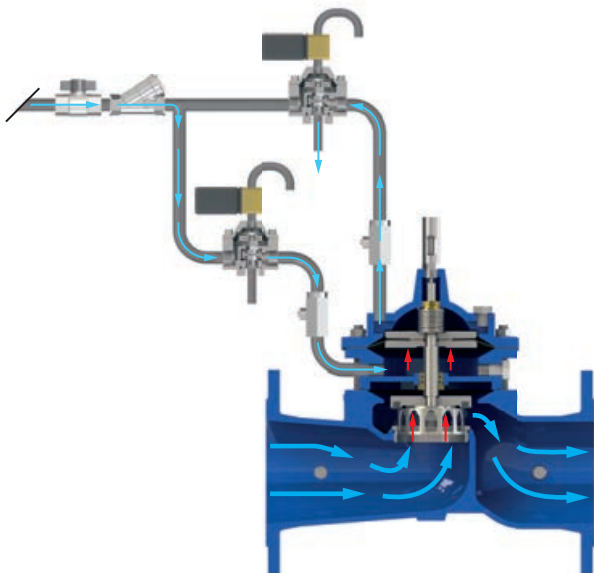

### Valve opening

The intermediate and upper chambers can be put in communication with the pressure source to allow for the on-off mode. In particular the picture shows the application with solenoid valves applied on PF 3 ways hydraulic relays, should the intermediate chamber be pressurized the force will act on the entire surface of the diaphragm flat causing the full opening of the valve.

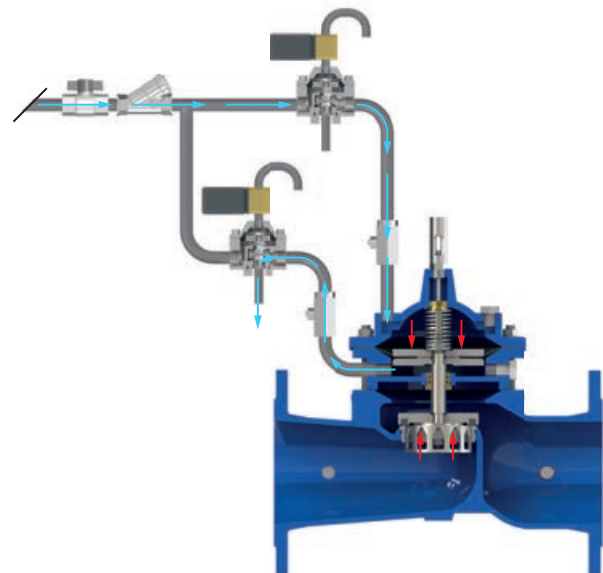

### Valve closing

Should the pressure be applied on the upper chamber, while the intermediate is discharged through the hydraulic relay, the valve obturator will be pushed down causing the closure of the valve. The needle valves are present on the communication circuits for both chambers and needed for the regulation to avoid unwanted pressure surges.

## Double chamber proportional pressure reducing valve **H-VAL 300/400-DC-PR**



The PF double chamber proportional pressure reducing valve is a globe pattern hydraulically operated automatic control valve that, installed in-line, will reduce and stabilize the upstream pressure to a lower downstream value according to a fixed ratio. Equipped with double chamber technology the valve is extremely reactive, increasing the safety and reliability of the line. Produced in compliance with PN 16/25 bar pressure standards and entirely made in ductile cast iron FBT epoxy painted and stainless steel, the valve is provided with anti-cavitation low flow stability system.

### Applications

- To perform a double pressure reduction stage in combination with other PF reducing control valves.
- The valve is used on the inlet supply line of storage tanks to stabilize pressure upstream of PF valves for level control either mechanical or pilot operated.
- On gravity fed supply lines and long downhill slopes to dissipate high differences in elevation, with multiple installations.

### Accessories

- Pressure measurement kit.
- Self-flushing and high capacity filter.
- Mechanical flow limiter.
- Double cage CP for high differential pressures and reduced noise.

### Note to the engineer

- Inlet and outlet pressure, and flow rate are required for the proper sizing.
- A minimum length of 3 DN downstream of the valve is recommended for the best accuracy.
- The downstream pressure will change depending on the inlet pressure and following a fixed ratio.

### Additional features

- H-VAL 300/400-DC-PR-FR double chamber proportional pressure reducing valve with back-flow prevention.
- H-VAL 300/400-DC-PR-5 double chamber proportional pressure reducing valve with solenoid control.

### Working conditions

- Fluid: treated water.
- Minimum operating pressure: 0,7 bar.
- Maximum operating pressure: 25 bar.
- Maximum temperature: 70°C.

## Operating principle

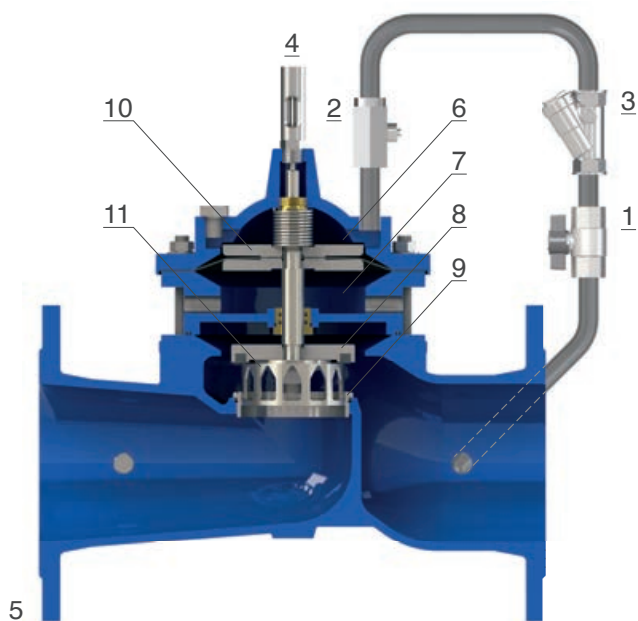

The PF Model H-VAL 300/400-DC-PR is an automatic control valve with double chamber technology, operated by means of the downstream pressure force (1) acting on the upper part of the control chamber (6) that separates the lower part with fluid flow from the intermediate chamber (7), in communication with the atmosphere. Due to the difference between the areas of the seal disks of the upper chamber (10) and the obturator (8), the valve will reduce the upstream pressure following a fixed ratio even in static conditions. This is due to the net force resulting from the downstream pressure acting on two difference surfaces.

The AC system (11) the valve is equipped with, allows for low flow stability and a higher resistance to cavitation compared with the standard design.

The flow in and out of the upper control chamber is regulated by the PF high sensitivity needle valve (2) in stainless steel, needed to regulate the response time of the valve and to guarantee accuracy also in case of rapid variation in demand.

## Installation layout

The installation lay-out of the H-VAL 300/400-DC-PR, in combination with a downstream pilot operated pressure stabilizing control valve H-VAL 310/410, includes sectioning devices and by-pass for maintenance operations along with a filter to prevent dirt from reaching the control valves. Anti-surge combination air valves WAVE 3S-AWH are recommended upstream and downstream of the installation, as well as direct acting pressure relief models WR/AM between the two pressure reducing units and further downstream.

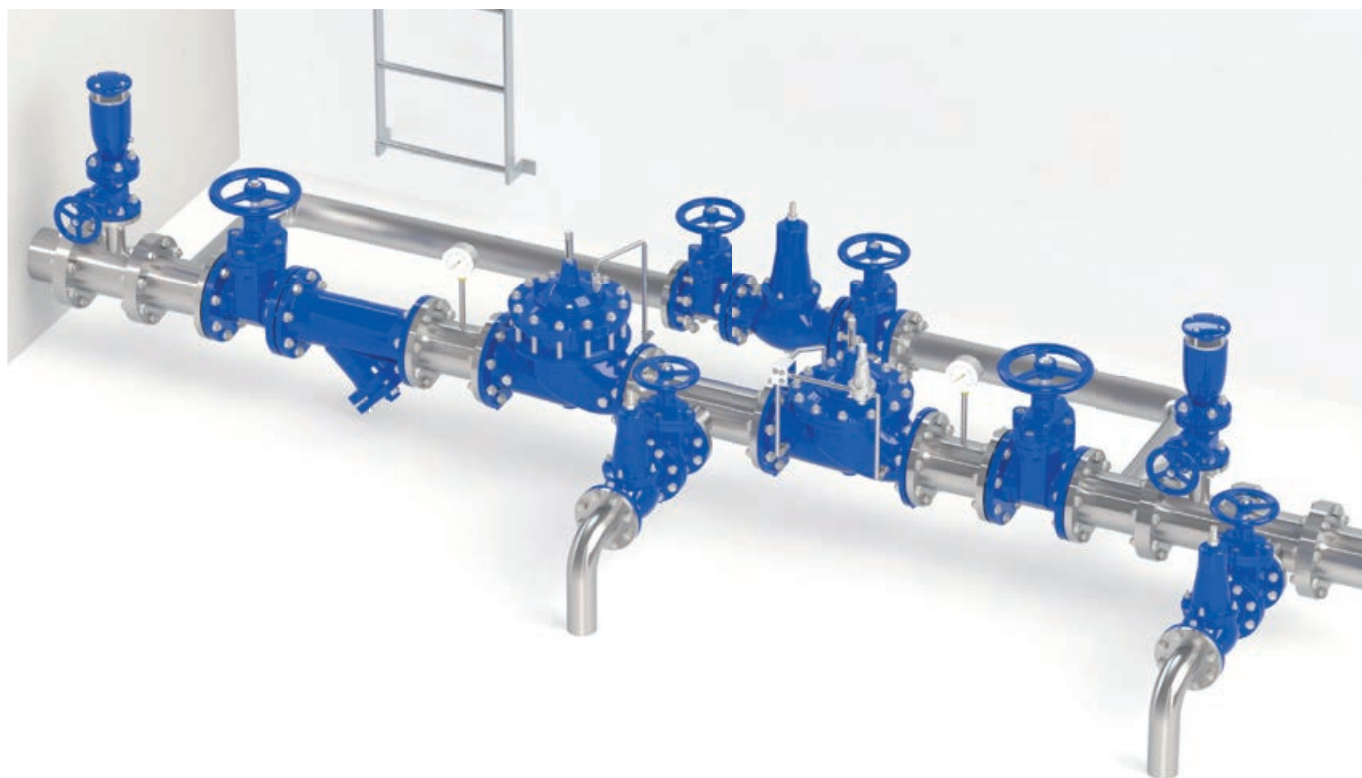



## Double chamber downstream pressure reducing stabilizing valve Mod. H-VAL 310/410-DC

The PF model H-VAL 310/410-DC is a globe pattern hydraulically operated automatic control valve that reduces and stabilizes the downstream pressure to a constant value, regardless of variations in demands and upstream pressure conditions. Normally equipped with visual position indicator and entirely made in ductile cast iron with FBT epoxy coating and stainless steel, the valve is designed to reduce head loss, throttling noise and cavitation damage. The PF pressure reducing stabilizing valve H-VAL 310/410-DC is extremely versatile and can be used for a wide range of applications.

### Applications

- Downstream of pumps to reduce the pressure on the main supply line.
- Installed in derivation from the main line to stabilize the pressure of secondary line and water users.
- As a protection against rise in pressure of industrial equipment and civil installations.
- On the inlet supply line of storage tanks to stabilize pressure and flow required for the level control.

### Accessories

- Linear position transmitter with 4-20 mA output Mod. PF CSPL.
- On-off position transmitter Mod. PF CSPO.
- Pressure measurement kit.
- Self-flushing and high capacity filter.

### Note to the engineer

- Inlet and outlet pressure, and flow rate are required for the proper sizing.
- PF anti-cavitation low flow stability plugs are recommended to provide an accurate regulation in case of low flow conditions.
- A minimum length of 3 DN downstream of the valve is recommended for the best accuracy.

### Additional features

- H-VAL 310/410-DC-FR downstream pressure reducing with back-flow prevention.
- H-VAL 310/410-DC-H downstream pressure reducing with high sensitivity pilot.
- H-VAL 310/410-DC-G downstream pressure reducing with over pressure guard.

### Working conditions

- Fluid: treated water.
- Minimum operating pressure: 0,7 bar.
- Maximum operating pressure: 25 bar.
- Maximum temperature: 70°C.

### Downstream pressure pilot adjustment range

- Blue spring: 0,7 to 7 bar.
- Red spring: 1,5 to 15 bar.
- Higher values up to 25 bar on request.
- Values lower than 0,7 available with high sensitivity pilots.



## Operating principle

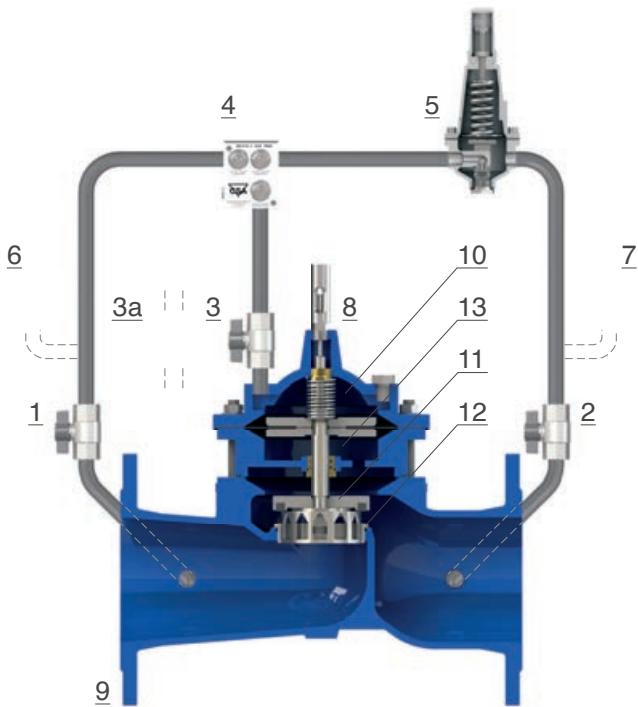

The PF model H-VAL 310/410-DC is an automatic control valve operated by a 2 ways pilot (5) with pre-set set and adjustable value. Should the downstream pressure rise above the pilot set point the latter will throttle and limit the flow to direct inlet pressure to the main chamber (10), thus pushing down the obturator (11) to generate the head loss required for the valve (9) to reduce and stabilize the downstream pressure to a constant value. Should the downstream pressure fall below the pilot set point the obturator (11) will raise increasing the passage through the seat (12), thus reducing the head loss followed by the rise in pressure. The flow in and out of the main chamber (10) is controlled by the PF unit regulation device with filter GR.I.F.O. (4) provided with three needle valves and flow stabilizers, needed for the valve's response time and accuracy also in case of rapid variation in demand. Thanks to the isolation ball valves (1-2-3) the control circuit and its components can be maintained without interrupting the flow through the main line.

## Installation layout

The H-VAL 310/410-DC installation lay-out includes sectioning devices (1, 2) and by-pass for maintenance operations, and a filter (3) to prevent dirt from reaching the control valve. The direct acting pressure reducer W-VAL HP (4) is the best choice on the by-pass thanks to its reliability also after long periods of inactivity. Anti-surge combination air valves WAVE 3S-AWH (6, 7) are recommended upstream and downstream as well as a pressure relief valve WR/AM (5) to prevent rise in pressure on the main line.

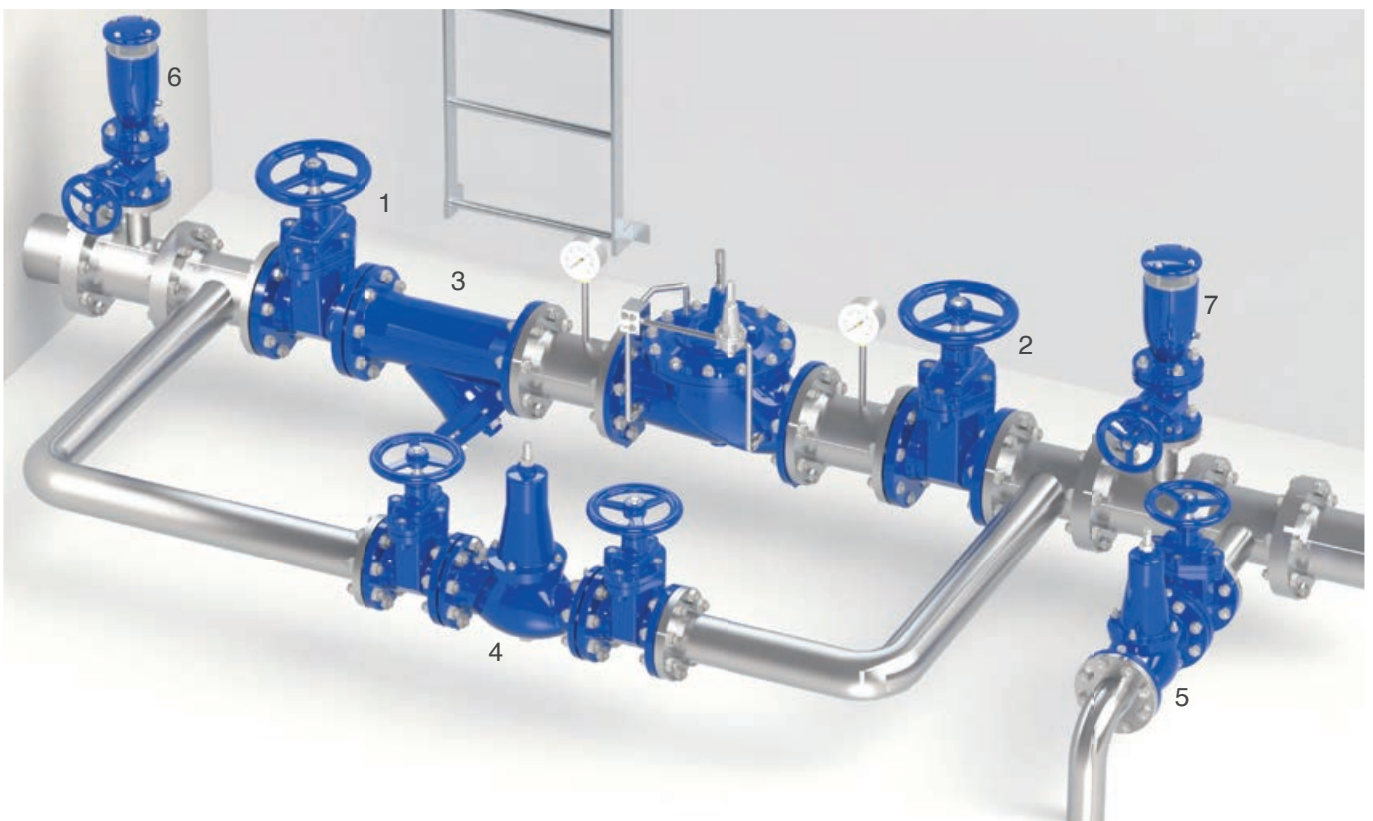



## Double chamber upstream pressure sustaining valve Mod. H-VAL 320/420-S-DC

The PF Model H-VAL 320/420-S-DC is a globe pattern hydraulically operated automatic control valve that, installed in-line, will sustain the upstream pressure to a pre-set and adjustable value regardless of variations in demand. Normally equipped with visual position indicator and entirely made in ductile cast iron with FBT epoxy coating and stainless steel, the valve is designed to reduce head loss, throttling noise and cavitation damage. The H-VAL 320/420-S-DC is extremely versatile and can be used for a wide range of applications in combination with several PF accessories and additional functions.

### Applications

- Downstream of pumps to prevent overload and for cavitation protection.
- On the inlet supply line of storage tanks to stabilize pressure and flow required for the level control.
- On gravity fed supply lines to ensure the minimum pressure to consumers located at higher elevation zones, in case of high consumption of the lower zones.

### Accessories

- Linear position transmitter with 4-20 mA output Mod. PF CSPL.
- On-off position transmitter Mod. PF CSPO.
- Pressure measurement kit.
- Self-flushing and high capacity filter.

### Note to the engineer

- Inlet pressure, outlet pressure, flow rate and application are required for the proper sizing and cavitation analysis.
- PF anti-cavitation low flow stability plugs are recommended to provide an accurate regulation in case of low flow conditions.
- A minimum length of 3 DN upstream of the valve is recommended for the best accuracy.

### Additional features

- H-VAL 320/420-S-DC-FR pressure sustaining valve with back-flow prevention.
- H-VAL 320/420-S-DC-5 pressure sustaining valve with solenoid control.
- H-VAL 320/420-S-DC-H pressure sustaining valve with high sensitivity pilot.

### Working conditions

- Fluid: treated water.
- Minimum operating pressure: 0,7 bar.
- Maximum operating pressure: 25 bar.
- Maximum temperature: 70°C.

### Upstream pressure pilot adjustment range

- Blue spring: 0,7 to 7 bar.
- Red spring: 1,5 to 15 bar.
- Higher values up to 25 bar on request.

## Operating principle

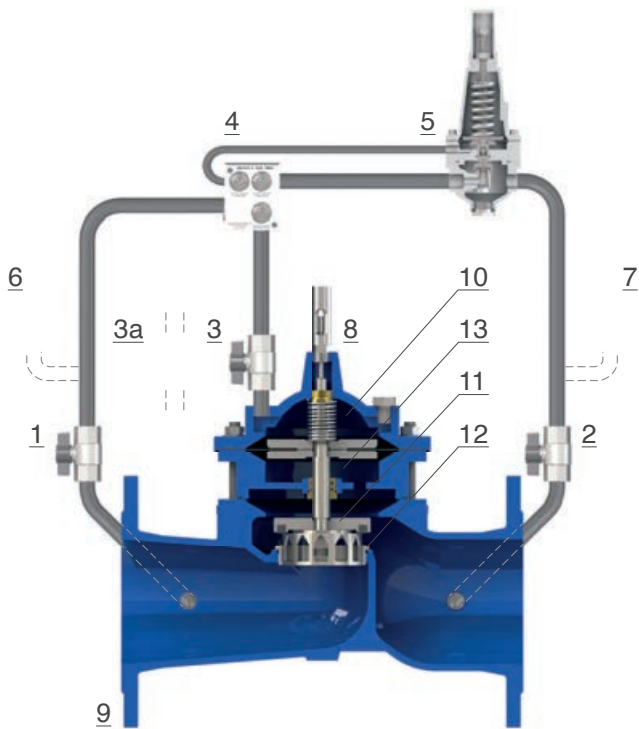

The PF Model H-VAL 320/420-S-DC is an automatic control valve operated by a high sensitivity two ways pilot (5), with pre-set and adjustable set point value, sensing the upstream pressure from the GR.I.F.O. (4). Should the line pressure rise above the pilot's set point the latter will open thus relieving the chamber (10) and moving the obturator (11) upwards, to discharge water and pressure through the main valve (9) downstream protecting the system. Should the upstream pressure be lower than the pilot's set point the latter will throttle (close eventually) diverting all pressure towards the main chamber (10) thus pushing the obturator (11) onto the seat (12), interrupting the flow rate.

The flow in and out of the main chamber is controlled by the PF exclusive unit flow GR.I.F.O. (4) providing accuracy and absence of unwanted chattering.

## Installation layout

The recommended installation lay-out of the PF H-VAL 320/420-S-DC, used as a pressure sustain in-line, includes sectioning devices (1, 2) and by-pass for maintenance operations, and a filter (3) to prevent dirt from reaching the control valve. The direct acting pressure sustain valve PF Mod. WR/AM (4) is the best choice on the by-pass thanks to its reliability also after long periods of inactivity. Anti-surge combination air valves PF Mod. WAVE 3S-AWH (5, 6) are recommended upstream and downstream of the installation.

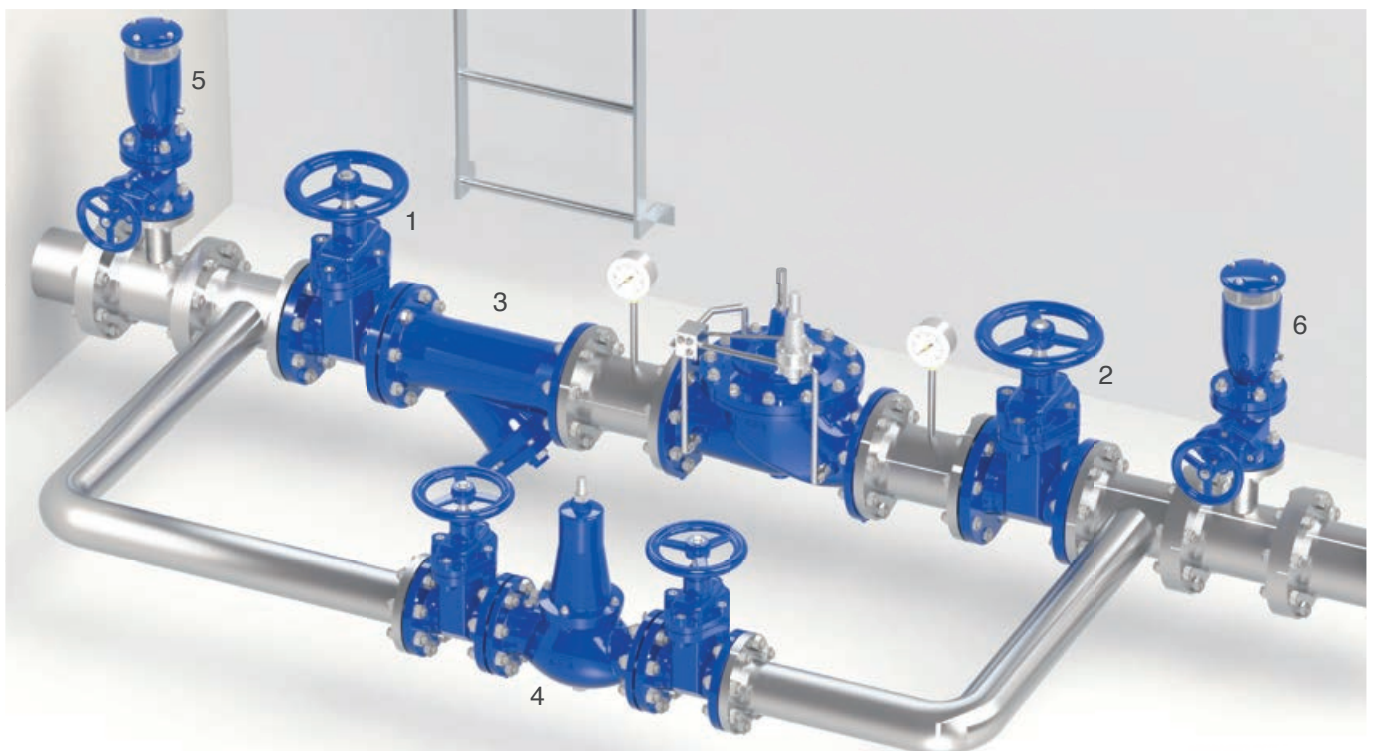



## H-VAL DC - Standard version - Technical details

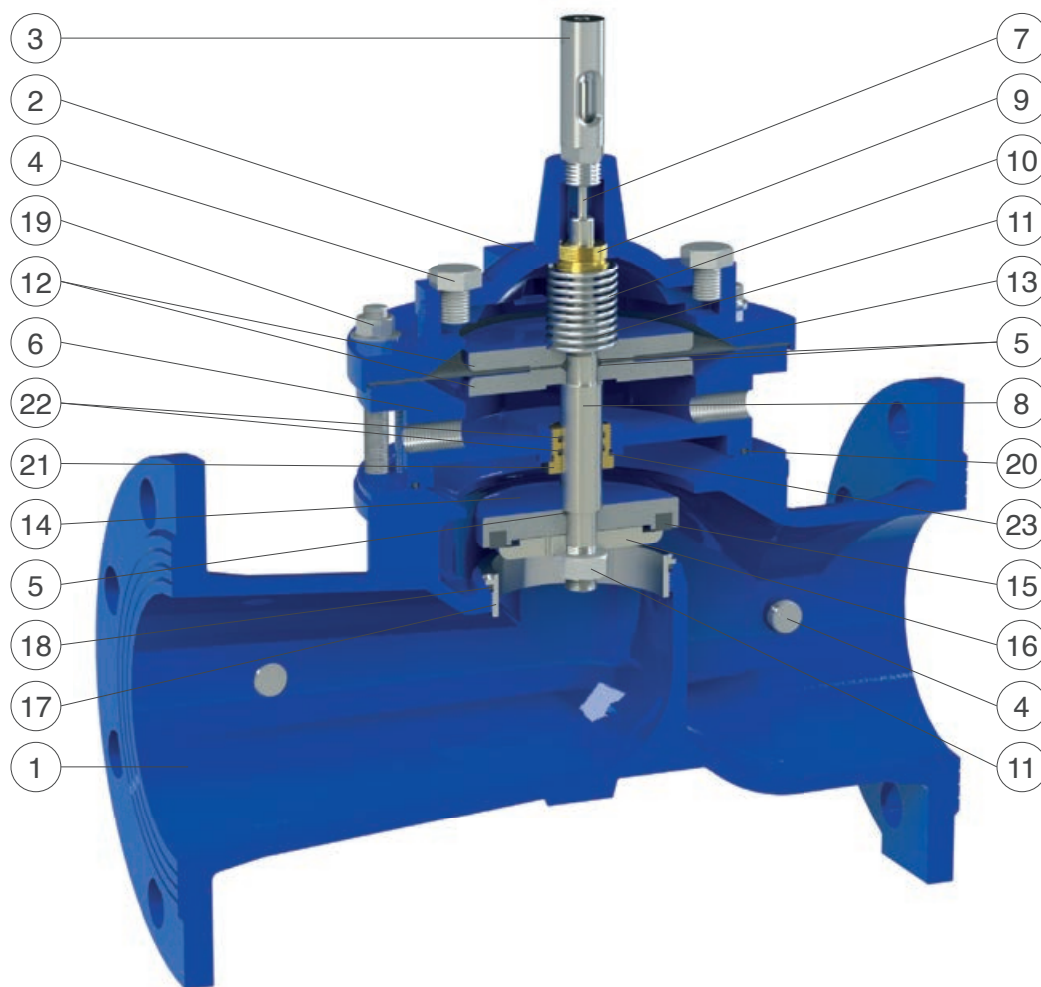

N.	Component	Standard material	Optional
1	Body	ductile cast iron GJS 500-7 or GJS 450-10	
2	Cap	ductile cast iron GJS 500-7 or GJS 450-10	
3	Position indicator	stainless steel AISI 303	
4	Pressure outlet taps	stainless steel AISI 316	
5	O-rings	NBR	EPDM/Viton
6	Intermediate body	painted steel	cast iron GJS 450-10
7	Indicator stem	stainless steel AISI 303	stainless steel AISI 316
8	Main shaft	stainless steel AISI 303	stainless steel AISI 316
9	Guide ring	bronze CuSn5Zn5Pb5	stainless s. AISI 303/316
10	Spring	stainless steel AISI 302	
11	Upper and lower locking nuts	stainless steel AISI 304	stainless steel AISI 316
12	Upper and lower flats	painted steel	stainless s. AISI 304/316
13	Diaphragm	polyamide-Nylon	neoprene/EPDM-Nylon
14	Obturator	painted steel	stainless s. AISI 304/316
15	Plane gasket	NBR	
16	Gasket holder	stainless steel AISI 303 (304 from DN 150)	stainless steel AISI 316
17	Seat	stainless steel AISI 303 (316 from DN 150)	stainless steel AISI 316
18	Seat O-ring	NBR	EPDM/Viton
19	Studs, nuts and washers	stainless steel AISI 304	stainless steel AISI 316
20	Intermediate body O-ring	NBR	EPDM/Viton
21	Guide screw	bronze CuSn5Zn5Pb5	stainless s. AISI 303/316
22	O-rings	NBR	EPDM/Viton
23	O-ring	NBR	EPDM/Viton

The list of materials and components is subject to changes without notice.



## H-VAL DC - Standard and anti-cavitation versions - Spare parts breakdown

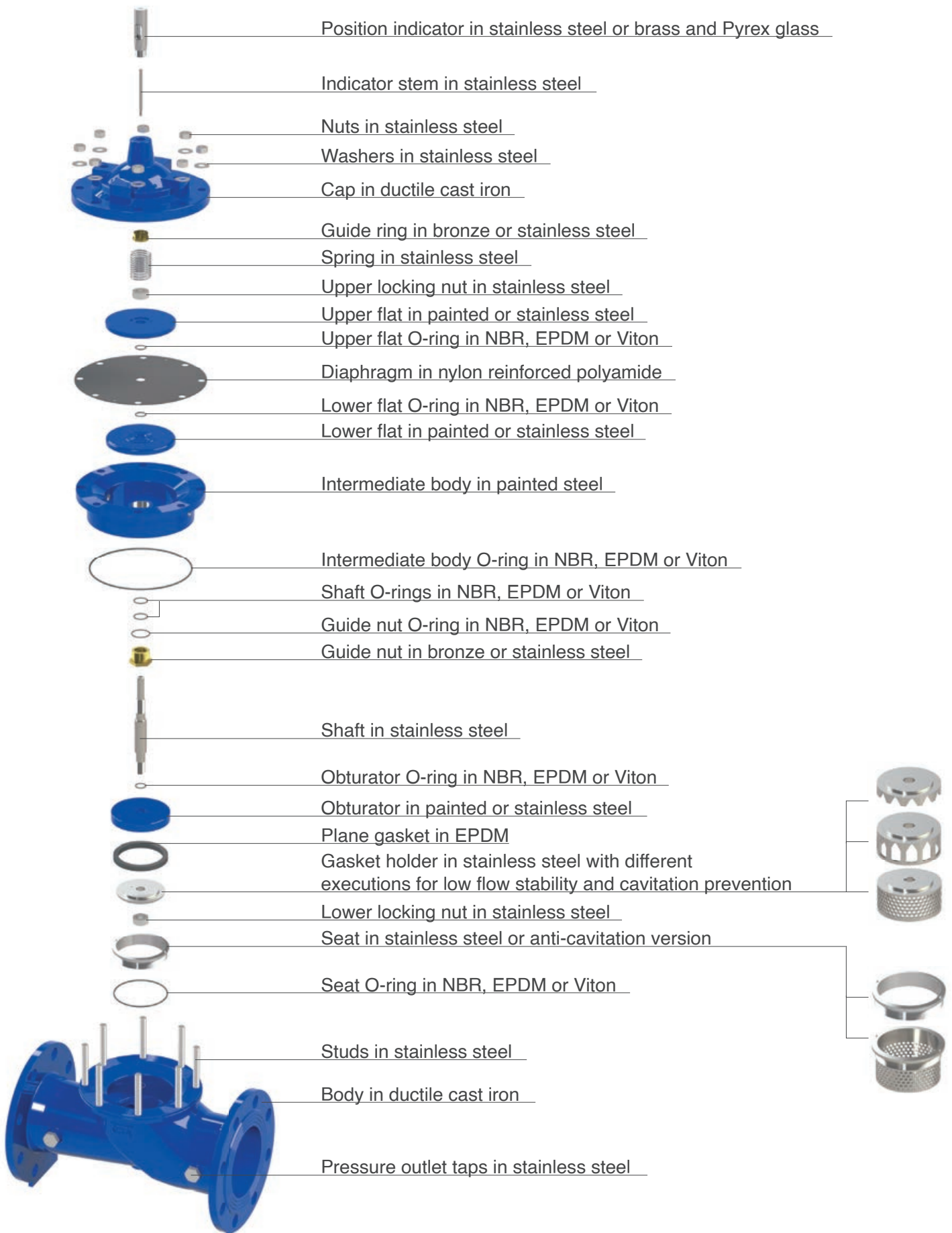

For the technical data and hydraulic performances of H-VAL DC make reference to the pages about H-VAL 400 and 300.