

Dival 600

Medium-low pressure gas regulator



Revision D - Edition 12/2024

**USE, MAINTENANCE
AND WARNING
INSTRUCTIONS**

1 - INTRODUCTION

FOREWORD

All rights reserved. No part of this publication may be reproduced, distributed, translated into other languages or transmitted by any electronic or mechanical media, including photocopies, recording or any other storage and retrieval system, for any other purposes that are not exclusively the personal use of the buyer, without the express written permission of the Manufacturer.

The manufacturer is in no way responsible for the consequences of operations carried out in a manner not in accordance with the manual.

GENERAL REMARKS

All operating, maintenance instructions and recommendations described in this manual must be observed. In order to obtain the best performance and to keep the equipment in efficient condition, the manufacturer recommends that maintenance operations be carried out regularly.

It is of particular importance that the personnel responsible for the equipment be trained in its use, maintenance and application of the safety instructions and procedures indicated in this manual.

COPYRIGHT 2024

© PIETRO FIORENTINI S.P.A.

1.1 - REVISION HISTORY

Revision index	Date
A	10/2022
B	09/2024
C	11/2024
D	12/2024

Tab. 1.1

INDEX

1 - INTRODUCTION	3
1.1 - REVISION HISTORY.....	5
2 - GENERAL INFORMATION	11
2.1 - MANUFACTURER IDENTIFICATION	11
2.2 - IDENTIFICATION OF THE PRODUCT	11
2.3 - REGULATORY FRAMEWORK.....	11
2.4 - WARRANTY	11
2.5 - SYMBOLS USED IN THE MANUAL.....	12
2.6 - ADDRESSEES, SUPPLY AND STORAGE OF THE INSTRUCTION MANUAL	13
2.7 - LANGUAGE	13
2.8 - NAMEPLATES APPLIED	14
2.8.1 - GLOSSARY FOR NAMEPLATES	15
2.9 - GLOSSARY OF UNITS OF MEASUREMENT	16
2.10 - QUALIFIED PROFESSIONAL FIGURES.....	17
3 - SAFETY	19
3.1 - GENERAL SAFETY WARNINGS.....	19
3.2 - PERSONAL PROTECTIVE EQUIPMENT.....	20
3.3 - RESIDUAL RISKS	21
3.3.1 - TABLE SHOWING RESIDUAL RISKS DUE TO PRESSURE	22
3.3.2 - TABLE OF RESIDUAL RISKS FOR POTENTIALLY EXPLOSIVE ATMOSPHERES	24
3.4 - OBLIGATIONS AND PROHIBITIONS	26
3.5 - SAFETY PICTOGRAMS	27
3.6 - RISK LEVEL	27

4 - DESCRIPTION AND OPERATION 29

4.1 - GENERAL DESCRIPTION	29
4.1.1 - REGULATOR REACTION MODES.....	30
4.2 - OPERATION.....	30
4.3 - INTENDED USE	32
4.3.1 - ENVISAGED USE	32
4.3.2 - REASONABLY FORESEEABLE MISUSE	32
4.3.3 - TYPES OF FLUIDS	32
4.4 - TECHNICAL FEATURES/PERFORMANCE	33
4.5 - POSSIBLE CONFIGURATIONS	34
4.5.1 - CONTROL HEADS.....	34
4.5.2 - ACCESSORIES	34
4.5.3 - REGULATOR WITH MONITOR FUNCTION.....	36
4.5.4 - SLAM-SHUT VALVE	39
4.5.4.1 - LA INCORPORATED SLAM-SHUT VALVE.....	40

5 - TRANSPORT AND HANDLING 43

5.1 - SPECIFIC WARNINGS FOR TRANSPORT AND HANDLING	43
5.1.1 - PACKAGING AND FASTENERS USED FOR TRANSPORT	44
5.2 - PHYSICAL CHARACTERISTICS OF THE EQUIPMENT	46
5.2.1 - DIVAL 600	46
5.2.2 - DIVAL 600 + LA.....	47
5.3 - EQUIPMENT ANCHORING AND LIFTING METHOD.....	48
5.3.1 - FORKLIFT HANDLING METHOD.....	49
5.3.2 - CRANE HANDLING METHOD	51
5.4 - PACKAGING REMOVAL.....	52
5.4.1 - PACKAGING DISPOSAL	52
5.5 - STORAGE AND ENVIRONMENTAL CONDITIONS	53
5.5.1 - PRE-INSTALLATION WARNINGS AFTER PROLONGED STORAGE	53

6 - INSTALLATION 55

6.1 - INSTALLATION PRE-REQUISITES.....	55
6.1.1 - ALLOWED ENVIRONMENTAL CONDITIONS.....	55
6.1.2 - CHECKS BEFORE INSTALLATION.....	56
6.2 - SPECIFIC SAFETY INSTRUCTIONS FOR THE INSTALLATION STEP	57
6.3 - GENERAL INFORMATION ON CONNECTIONS	58
6.4 - REGULATOR INSTALLATION POSITIONS.....	59
6.5 - INSTALLATION PROCEDURES	60
6.5.1 - EQUIPMENT INSTALLATION PROCEDURES	60
6.5.2 - CONNECTION OF THE SENSING LINES TO THE DOWNSTREAM PIPING.....	60
6.6 - POST-INSTALLATION AND PRE-COMMISSIONING CHECKS	62

7 - COMMISSIONING/MAINTENANCE EQUIPMENT..... 63

7.1 - LIST OF EQUIPMENT.....	63
7.2 - EQUIPMENT NEEDED FOR THE DIFFERENT CONFIGURATIONS.....	65

8 - COMMISSIONING 67

8.1 - GENERAL WARNINGS	67
8.1.1 - SAFETY REQUIREMENTS FOR COMMISSIONING	67
8.2 - PRELIMINARY PROCEDURES FOR COMMISSIONING	68
8.3 - PROPER COMMISSIONING CHECK	69
8.4 - CALIBRATION OF EQUIPMENT AND ACCESSORIES INSTALLED.....	69
8.5 - REGULATOR COMMISSIONING PROCEDURE	70
8.6 - COMMISSIONING PROCEDURE OF REGULATION LINE: DIVAL 600 REGULATOR + DIVAL 600 REGULATOR WITH IN LINE MONITOR FUNCTION	72
8.6.1 - PRESSURISING WITH EXTERNAL SOURCE.....	76
8.7 - COMMISSIONING PROCEDURE OF DIVAL 600 REGULATOR WITH LA SLAM-SHUT VALVE.....	78
8.7.1 - INTERNAL TIGHTNESS CHECK OF LA SLAM-SHUT VALVE.....	78
8.7.2 - COMMISSIONING OF THE DIVAL 600 REGULATOR WITH LA SLAM-SHUT VALVE.....	79
8.7.3 - PROCEDURE FOR CALIBRATING THE PRESSURE SWITCH FOR THE LA INCORPORATED SLAM-SHUT VALVE.....	82
8.8 - COMMISSIONING PROCEDURE OF REGULATION LINE: DIVAL 600 REGULATOR + DIVAL 600 REGULATOR WITH IN LINE MONITOR + LA SLAM-SHUT VALVE FUNCTION	86
8.9 - DEVICE CALIBRATION.....	90
8.9.1 - PRESSURE SWITCH CALIBRATION FOR THE LA SLAM-SHUT VALVE	90

9 - MAINTENANCE AND FUNCTIONAL CHECKS..... 91

9.1 - GENERAL WARNINGS	91
9.2 - PERIODICALLY CHECKING AND INSPECTING THE EQUIPMENT FOR PROPER OPERATION.....	93
9.3 - ROUTINE MAINTENANCE	94
9.3.1 - GENERAL SAFETY WARNINGS.....	94
9.3.2 - REPLACEMENT FREQUENCY FOR COMPONENTS SUBJECT TO WEAR	95
9.4 - ROUTINE MAINTENANCE PROCEDURES.....	97
9.4.1 - TIGHTENING TORQUES	98
9.4.2 - REPLACING ELEMENTS SUBJECT TO WEAR AND ABRASION.....	105
9.4.3 - REGULATOR DIVAL 600	106
9.4.4 - LA SLAM-SHUT VALVE	130
9.4.5 - PROCEDURE FOR RECOMMISSIONING AFTER MAINTENANCE	142

10 - TROUBLESHOOTING..... 143

10.1 -GENERAL WARNINGS	143
10.2 -OPERATOR QUALIFICATION SPECIFICATION.....	144
10.3 -TROUBLESHOOTING PROCEDURES	144
10.4 -TROUBLESHOOTING TABLES	145
10.4.1 -TROUBLESHOOTING DIVAL 600 REGULATOR	145
10.4.2 -LA SLAM-SHUT VALVE TROUBLESHOOTING.....	145

11 - UNINSTALLATION AND DISPOSAL 147

11.1 -GENERAL SAFETY WARNINGS.....	147
11.2 -QUALIFICATION OF THE OPERATORS IN CHARGE.....	147
11.3 -UNINSTALLATION.....	147
11.4 -INFORMATION REQUIRED IN CASE OF RE-INSTALLATION.....	147
11.5 -DISPOSAL INFORMATION.....	148

12 - RECOMMENDED SPARE PARTS 149

12.1 -GENERAL WARNINGS	149
12.2 -HOW TO REQUEST SPARE PARTS.....	149

13 - CALIBRATION TABLES 151

13.1 -CALIBRATION TABLES DIVAL 600 REGULATOR.....	151
13.2 -CALIBRATION TABLE FOR SLAM-SHUT VALVE	154

2 - GENERAL INFORMATION

2.1 - MANUFACTURER IDENTIFICATION

Manufacturer	PIETRO FIORENTINI S.P.A.
Address	Via Enrico Fermi, 8/10 36057 Arcugnano (VI) - ITALY Tel. +39 0444 968511 Fax +39 0444 960468 www.fiorentini.com sales@fiorentini.com

Tab. 2.2

2.2 - IDENTIFICATION OF THE PRODUCT

Equipment	MEDIUM PRESSURE REGULATOR
Model	DIVAL 600

Tab. 2.3

2.3 - REGULATORY FRAMEWORK

PIETRO FIORENTINI S.P.A., with registered offices in Arcugnano (Italy) - Via E. Fermi, 8/10, declares under its sole responsibility that the equipment of the DIVAL 600 series described in this manual is designed, manufactured, tested and checked in compliance with the requirements of EN 334 standard on gas pressure regulators.

The equipment complies with the requirements of Directive 2014/68/EU ("Pressure Equipment Directive" PED). The assessment procedure adopted is in accordance with module H1 as per Annex III of the Directive.

NOTICE!

The declaration of conformity in its original version is delivered together with the equipment and this operating and warning manual.

2.4 - WARRANTY

PIETRO FIORENTINI S.P.A. guarantees that the equipment was manufactured using the best materials, with high quality workmanship, and complies with the quality requirements, specifications and performance set out in the order.



The warranty shall be considered null and void and PIETRO FIORENTINI S.P.A. shall not be liable for any damage and/or malfunctions:

- due to any acts or omissions of the purchaser or end-user, or any of their carriers, employees, agents, or any third party or entity;
- in the event that the purchaser, or a third party, makes changes to the equipment supplied by PIETRO FIORENTINI S.P.A. without the prior written approval of the latter;
- in the event of failure by the purchaser to comply with the instructions contained in this manual, as provided by PIETRO FIORENTINI S.P.A.

NOTICE!

The warranty conditions are specified in the commercial contract.

2.5 - SYMBOLS USED IN THE MANUAL

Symbol	Definition
	Symbol used to identify important warnings for the safety of the operator and/or equipment.
	Symbol used to identify information of particular importance in the instruction manual. The information may also concern the safety of the personnel involved in using the equipment.
	Obligation to consult the instruction manual/booklet. Indicates a requirement for the personnel to refer to (and understand) the operating and warning instructions of the machine before working with or on it.

Tab. 2.4

HAZARD!

Alerts to a hazard with a high level of risk, an imminent hazardous situation which, if not prevented, will result in death or severe damage.

WARNING!

Alerts to a hazard with a medium level of risk, a potentially hazardous situation which, if not prevented, may result in death or severe damage.

ATTENTION!

Alerts to a hazard with a low level of risk, a potentially hazardous situation which, if not prevented, could result in minor or moderate damage.

NOTICE!

Alerts to specific warnings, directions or notes of particular concern, that are not related to physical injury, as well as practices for which physical injury is not likely to occur.

2.6 - ADDRESSEES, SUPPLY AND STORAGE OF THE INSTRUCTION MANUAL

The instruction manual is intended for qualified technicians responsible for operating and managing the equipment throughout its service life.

It contains the necessary information to properly use the equipment and keep its functional and qualitative characteristics unchanged over time. All information and warnings for safe, correct use are also provided.

The instruction manual, as well as the declaration of conformity and/or test certificate, is an integral part of the equipment and must always accompany it whenever it is moved or resold. It is up to the user to keep this documentation intact for reference throughout the lifespan of the equipment.

WARNING!

Removing, rewriting or editing the pages of the manual and their contents is not allowed.

Keep the instruction manual near the equipment, in an accessible place known by all qualified technicians involved in using and running it.

PIETRO FIORENTINI S.p.A. shall not be held liable for any damage to people, animals and property caused by failure to adhere to the warnings and operating procedures described in this instruction manual.

2.7 - LANGUAGE

The original instruction manual was drawn up in Italian.

Any translations into additional languages are to be made from the original instruction manual.

HAZARD!

The Manufacturer is not responsible for any incomplete translations. If any inconsistency is found, please refer to the text of the original manual.

If inconsistencies are found or the text does not make sense:

- stop any actions;
- immediately contact the relevant offices of PIETRO FIORENTINI S.p.A.

WARNING!

PIETRO FIORENTINI S.p.A. shall be held liable for the information provided in the original manual only.

2.8 - NAMEPLATES APPLIED

WARNING!

**Removing nameplates and/or replacing them with other plates is strictly not allowed.
Should the plates be unintentionally damaged or removed, the customer must notify
PIETRO FIORENTINI S.p.A.**

The equipment and its accessories are provided with nameplates (from Id.1 to Id.2).

The nameplates specify identification details of the equipment and its accessories to be provided, if necessary, to PIETRO FIORENTINI S.p.A.

“Tab. 2.5” shows the nameplates applied:

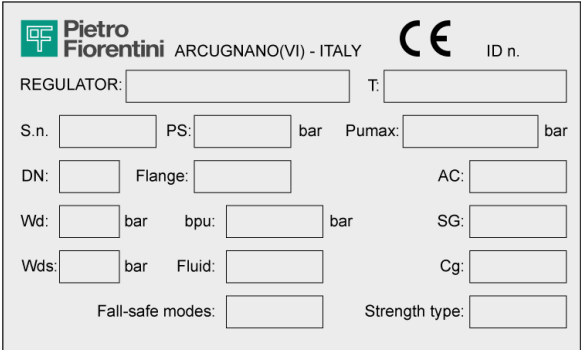
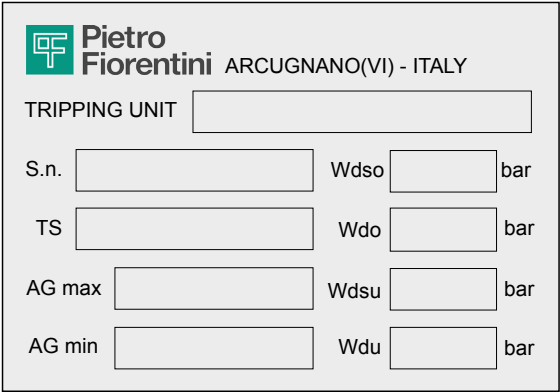
Id.	Type	Image
1	NAMEPLATE REGULATOR (EC version) AND REGULATOR WITH IN LINE MONITOR FUNCTION	
2	NAMEPLATE SLAM-SHUT VALVE	

Tab. 2.5

2.8.1 - GLOSSARY FOR NAMEPLATES

The terms and abbreviations used on nameplates are described in "Tab. 2.6":

Term	Description
AC	Accuracy class.
AG max	Slam-shut valve accuracy class due to pressure increase. "OPSO" (Overpressure shut-off).
AG min	Slam-shut valve accuracy class due to pressure decrease. "UPSO"(Underpressure shut off).
bpu	Range of inlet pressure for which the regulator ensures a given accuracy class.
CE	Marking certifying compliance with applicable European directives.
Cg	Flow rate coefficient.
Class	Alphanumeric designation used for reference purposes related to a combination of mechanical and dimensional characteristics for flanges, in accordance with the relevant parts of EN 1759 series, which includes the word Class followed by a dimensionless whole number.
DN	Nominal size of connections.
Fail safe mode	Regulator reaction mode (Fail open or Fail close).
Flange	Type of flanged connections or type of connection thread.
Fluid	Type of fluid compatible with the equipment.
ID no.	Number of the Notified Body participating in the conformity assessment of the equipment.
Pilot	Pilot family.
PS	Maximum permissible pressure for which the equipment was designed.
Pumax	Maximum inlet pressure at which the regulator can operate continuously under specific conditions.
REGULATOR	Equipment family.
SG	Shut-off pressure class.
Slam-shut device	Slam-shut valve family.
S.n.	Equipment serial number.
Strength type	Strength class: Integral strength or differential strength (DS).
T	Permissible temperature range (min. and max.) for which the equipment was designed.
Tripping unit	Pressure switch family.
Type	Accessory type and family.
Wd	Full setpoint range that can be obtained from the regulator by adjusting and/or replacing certain components (e.g. replacement of valve seat or control element, e.g. spring).
Wdo	Full setpoint range with regard to tripping caused by increased pressure in the pressure switch incorporated in the slam-shut valve. This range can be obtained by adjusting and/or replacing the components (for example, spring or sensitive element).
Wds	Full setpoint range that can be obtained from the regulator by adjusting but not replacing the components.
Wdso	Full setpoint range with regard to tripping caused by increased pressure in the pressure switch incorporated in the slam-shut valve. This range can be obtained by adjusting but not replacing the components.
Wdu	Full setpoint range with regard to tripping caused by decreased pressure in the pressure switch incorporated in the slam-shut valve. This range can be obtained by adjusting and/or replacing the components (for example, spring or sensitive element).

Term	Description
Wdsu	Full setpoint range with regard to tripping caused by decreased pressure in the pressure switch incorporated in the slam-shut valve. This range can be obtained by adjusting but not replacing the components.

Tab. 2.6

2.9 - GLOSSARY OF UNITS OF MEASUREMENT

Type of measurement	Unit of measurement	Description
Volumetric flow rate	Sm ³ /h	Standard cubic metres per hour
	Scfh	Standard cubic feet per hour
Pressure	bar	Unit of measurement in the CGS system
	psi	Pounds per square inch
	"wc	Water column inch
	Pa	Pascal
Temperature	°C	Degree centigrade
	°F	Fahrenheit degree
	K	Kelvin
Tightening torque	Nm	Newton-metre
	ft-lbs	Foot per pound
Sound pressure	dB	Decibel
Other measures	V	Volt
	W	Watt
	Ω	Ohm

Tab. 2.7

2.10 - QUALIFIED PROFESSIONAL FIGURES

Qualified operators in charge of using and managing the equipment throughout its technical service life:

Professional figure	Definition
Mechanical maintenance technician	<p>Qualified technician able to:</p> <ul style="list-style-type: none"> perform preventive/corrective maintenance operations on all mechanical parts of the equipment subject to maintenance or repair; access all device parts for visual inspection, equipment checks, adjustments and calibrations. <p>The maintenance mechanical technician is not authorised to operate on live electrical systems (if any).</p>
Electrical maintenance technician	<p>Qualified technician able to:</p> <ul style="list-style-type: none"> perform preventive/corrective maintenance operations on all electrical parts of the device subject to maintenance or repair; read wiring diagrams and check the correct functional cycle; perform adjustments and operate on electrical systems for maintenance, repair and replacement of worn parts. <p>The electrical maintenance technician can operate in the presence of voltage inside electrical panels, junction boxes, control equipment etc. only if he/she is deemed to be suitable (S.P.).</p> <p>For general requirements, refer to the IEC EN 50110-1:2014 standard.</p>
Worker in charge of transport, handling, unloading and placement on site	<p>Operator qualified to:</p> <ul style="list-style-type: none"> use lifting equipment; handle materials and equipment. <p>The equipment must be lifted and handled strictly in accordance with the instructions provided by the manufacturer as well as the regulations in force at the place where the equipment is installed.</p>
Installer	<p>Qualified operator able to:</p> <ul style="list-style-type: none"> carry out all the operations necessary to properly install the equipment; perform all the operations necessary for the proper functioning of the equipment and the system in safety.
User's technician	<p>Technician trained and authorised to use and manage the equipment for the activities for which it was supplied. They must:</p> <ul style="list-style-type: none"> be able to perform all operations required to properly run the equipment and the system, ensuring their own safety and that of any personnel on site; have proven experience in properly using the equipment similar to that described in this instruction manual, and be trained, informed and instructed in this regard. <p>The technician may carry out maintenance only if authorised/qualified to do so.</p>

Tab. 2.8

3 - SAFETY

3.1 - GENERAL SAFETY WARNINGS

WARNING!

The equipment described in this instruction manual is:

- a device subjected to pressure in pressurised systems;
- normally installed in systems carrying flammable gases (for example: natural gas).

WARNING!

If the gas used is a combustible gas, the installation area of the equipment is defined as a “danger zone” as there are residual risks that potentially explosive atmospheres may be generated.

In “danger zones” and in close proximity thereto:

- there must not be any effective sources of ignition;
- smoking is not allowed.

ATTENTION!

Authorised operators must not carry out operations or services on their own initiative that do not fall within their competence.

Never operate the equipment:

- while under the influence of intoxicating substances such as alcohol;
- if you are using drugs that may lengthen reaction times.

NOTICE!

The employer must train and inform operators on how to behave during operations and on the equipment to be used.

Before installation, commissioning or maintenance, operators must:









- take note of the safety regulations applicable to the place of installation they are working in;
- obtain the necessary permits to operate when required;
- wear the personal protective equipment required by the procedures described in this instruction manual;
- ensure that the required collective protective equipment and safety information are available in the area they are operating in.

3.2 - PERSONAL PROTECTIVE EQUIPMENT

"Tab. 3.9" shows the personal protective equipment (PPE) and its description. An obligation is associated with each symbol.

Personal protective equipment means any equipment intended to be worn by the worker in order to protect them against one or several risks that are likely to threaten their safety or health during work.

For the operators in charge, depending on the type of work requested, the most appropriate PPE of the following will be reported and must be used:

Symbol	Meaning
	Obligation to use safety or insulated gloves. Indicates a requirement for the personnel to use safety or insulated gloves.
	Obligation to use safety goggles. Indicates a requirement for personnel to use protective goggles for eye protection.
	Obligation to use safety shoes. Indicates a requirement for the personnel to use accident-prevention safety shoes.
	Obligation to use noise protection equipment. Indicates a requirement for the personnel to use ear muffs or ear plugs to protect their hearing.
	Obligation to wear protective clothing. Indicates a requirement for the personnel to wear specific protective clothing.
	Obligation to use a protective mask. Indicates a requirement for the personnel to use respiratory masks in the event of a chemical risk.
	Obligation to use a protective helmet. Indicates a requirement for the personnel to use protective helmets.
	Obligation to wear high visibility vests. Indicates a requirement for the personnel to use high visibility vests.

Tab. 3.9

WARNING!

Each licensed operator is obliged to:

- **take care of his/her own health and safety and that of other people in the workplace who are affected by his/her actions or omissions, in accordance with the training, instructions and equipment provided by the employer;**
- **appropriately use the PPE made available;**
- **immediately report to the employer, the manager or the person in charge any deficiencies in the equipment and devices, as well as any dangerous conditions they may become aware of.**

3.3 - RESIDUAL RISKS

In accordance with the requirements of PED 2014/68/EU, point 1.2 of Annex I, below is an assessment of the risks associated with the equipment and an indication of the principles adopted for their prevention, according to the following classification:

- a) Elimination and/or reduction of the risk.
- b) Application of appropriate protective measures.
- c) Information to users about residual risks.

3.3.1 - TABLE SHOWING RESIDUAL RISKS DUE TO PRESSURE

Risk and hazard	Event and Cause	Effect and consequence	Solution and prevention
Pressurised gas leakage. Projection of metallic and non-metallic pressurised parts.	<ul style="list-style-type: none"> Violent impact; Impact (also due to falling, improper handling, etc.). 	<ul style="list-style-type: none"> Deformation; Broken connections and, if pressurised, even burst. 	<p>a. Handling and installation with appropriate devices to avoid localised stress.</p> <p>b. Installation in suitable places and spaces with appropriate guards and packaging.</p> <p>c. Information in the instructions for use and warning.</p>
Pressurised gas leakage. Projection of metallic and non-metallic pressurised parts.	<ul style="list-style-type: none"> Use of inappropriate fluids. 	<ul style="list-style-type: none"> Corrosion; Embrittlement; Explosion. 	<p>a. The user must check compliance of the used fluid with the specifications on the data plate.</p>
Pressurised gas leakage. Projection of metallic and non-metallic pressurised parts.	<ul style="list-style-type: none"> Operation at temperatures below the minimum permissible temperature. 	<ul style="list-style-type: none"> Embrittlement; Breakage; Explosion. 	<p>a. Install in places where the temperature is not below the minimum permissible temperature and/or insulate the equipment adequately.</p> <p>b. The minimum temperature allowed is indicated on the data plate.</p>
Pressurised gas leakage. Projection of metallic and non-metallic pressurised parts. Explosion.	<ul style="list-style-type: none"> Overpressure or exceedance of the rated limit values (maximum pressure allowed) 	<ul style="list-style-type: none"> Explosion; Breaks; Cracks; Permanent deformations. 	<p>a. The device has appropriate design safety margins.</p> <p>b. The user must check the maximum pressure applicable to the equipment.</p> <p>c. The maximum allowable pressure is highlighted on the appropriate plate on the equipment.</p>
Falling of the equipment.	<ul style="list-style-type: none"> Dangerous handling. 	<ul style="list-style-type: none"> Deformation; Cracking; Breakage. 	<p>b. The user must have suitably sized lifting equipment.</p> <p>c. The above requirements are referred to in the equipment use and warning manual.</p>
Pressurised fluid leakage. Projection of metallic and non-metallic pressurised parts.	<ul style="list-style-type: none"> Incorrect fixing of the equipment. 	<ul style="list-style-type: none"> Deformation; Breakage. 	<p>a. The device is equipped with unified type process connections and compression fittings.</p> <p>b. The user must ensure correct fixing to the line.</p> <p>c. Directions in the instructions for use and warning.</p>
Explosion of the device. Pressurised fluid leakage. Projection of metallic parts.	<ul style="list-style-type: none"> Operation at temperatures above the maximum permissible temperature. 	<ul style="list-style-type: none"> Reduction of mechanical resistance and breakage of the device; Explosion. 	<p>a. The user must equip the system with suitable safety and control devices.</p> <p>b. The maximum temperature allowed is indicated on the data plate.</p>
Pressurised gas leakage.	<ul style="list-style-type: none"> Device maintenance with the system running. 	<ul style="list-style-type: none"> Inappropriate opening of pressurised chambers. 	<p>a. The user must perform any maintenance with the equipment not in operation.</p> <p>b. The above requirements are referred to in the use and warning manual.</p>

Risk and hazard	Event and Cause	Effect and consequence	Solution and prevention
Pressurised gas leakage. Projection of metallic and non-metallic pressurised parts.	<ul style="list-style-type: none"> External loads bearing on the device. 	<ul style="list-style-type: none"> Deformation; Cracking and slot formation; If under pressure, burst also. 	a. With the exclusion of what is set out in the project, the user must verify that no additional concentrated load bears on the device.
Pressurised gas leakage. Projection of metallic and non-metallic pressurised parts.	<ul style="list-style-type: none"> Electrostatic potential, differential stray currents. 	<ul style="list-style-type: none"> Corrosion localised in the device. 	b. The user must equip the device with the necessary protection and earthing devices. c. The above requirements are referred to in the use and warning manual.
Pressurised gas leakage. Projection of metallic and non-metallic pressurised parts.	<ul style="list-style-type: none"> Humidity; Environments with aggressive atmosphere. 	<ul style="list-style-type: none"> Deterioration of external surfaces; Corrosion. 	a. The user must periodically check the state of conservation of the external surfaces. b. The above requirements are referred to in the use and warning manual.

Tab. 3.10

3.3.2 - TABLE OF RESIDUAL RISKS FOR POTENTIALLY EXPLOSIVE ATMOSPHERES

“Tab. 3.11” shows the conditions that can lead to the generation of a potentially explosive atmosphere respectively for:

- DIVAL 600 pressure regulator;
- the LA slam-shut valve.

Considering that the silencer does not have active functional parts, in this analysis it is considered an integral part of the DIVAL 600 regulator.

The table is valid for use with natural gas with a density of no more than 0.8; for different densities, the installation and environmental conditions must also be evaluated.

WARNING!

If the gas used is a combustible gas, the installation area of the equipment is defined as a “danger zone” as there are residual risks that potentially explosive atmospheres may be generated.

There must be no effective sources of ignition in “danger zones” and in close proximity thereto.

Operating conditions	Potentially explosive atmosphere	Normative references	Management measures included in the instructions for use and warning
First start-up	No	<ul style="list-style-type: none"> • During the production cycle and before the CE marking according to Directive 2014/68/EU, the external tightness of the equipment is checked at a value of 1.1 PS (in accordance with Standard EN 334). • Before commissioning, the external tightness of the portion of the system on which the equipment is installed is checked at a suitable pressure (in accordance with standards EN 12186 and EN 12279). 	The instructions for use indicate the need to meet the requirements in Standards EN 12186 and EN 12279.
Operation in normal conditions	No	<p>The indications in the previous point apply, in addition:</p> <ul style="list-style-type: none"> • the equipment is installed outdoors or in an environment with natural ventilation (in accordance with Standards EN 12186 and EN 12279); • the installation is subject to surveillance according to current national rules/good practice/the equipment manufacturer's instructions (in accordance with the provisions of Standard EN 12186 and Standard EN 12279). 	<p>The instructions for use indicate that:</p> <ul style="list-style-type: none"> • any environment in which the equipment is installed must meet the requirement of Standards EN 12186 and EN 12279; • periodic checks and maintenance must be carried out during surveillance in accordance with the national rules in force (if any), and with the specific manufacturer's recommendations.
Breakage of the control head diaphragm (malfunction)	No	<p>This event must be considered a rare malfunction.</p> <p>All atmospheric pressure chambers delimited on at least one side by a diaphragm must be channelled to a safe area (in accordance with the provisions of Standard EN 12186 and Standard EN 12279).</p>	The instructions for use indicate the need to meet the requirements of Standards EN 12186 and EN 12279.

Operating conditions	Potentially explosive atmosphere	Normative references	Management measures included in the instructions for use and warning
Breakage of other non-metallic parts (malfunction)	No	This type of malfunction is not reasonably expected as it involves static sealing (to the outside).	-
Decommissioning	No	<ul style="list-style-type: none"> The pressure of the system section in which the equipment is installed must be reduced with appropriate vent lines channelled to a safe area (in accordance with the provisions of Standard EN 12186 and Standard EN 12279). The residual gas must be discharged as indicated above. 	The instructions for use indicate the need to meet the requirements of Standards EN 12186 and EN 12279
Reboot	No	<ul style="list-style-type: none"> After reassembling the regulator, carry out an external leakage test at a convenient pressure value as specified by the manufacturer. Before commissioning, the external sealing of the system portion on which the equipment is installed is checked at a suitable pressure (in accordance with the provisions of standards EN 12186 and EN 12279). 	The instructions for use indicate: <ul style="list-style-type: none"> the minimum conditions for testing internal leakage; the need to meet the requirements of Standards EN 12186 and EN 12279.

Tab. 3.11

3.4 - OBLIGATIONS AND PROHIBITIONS

The following is a list of obligations and prohibitions to be observed for the safety of the operator.

It is mandatory to:



- carefully read and understand the instructions for use and warning;
- check whether the downstream equipment is suitably sized according to the performance required of the regulator in the actual operating condition;
- before installing the equipment, the data on the nameplates must be checked;
- Avoid violent shocks and impacts that could damage the equipment and, as a result, cause the pressure fluid to escape.

It is forbidden to:

- operate in various capacities on the equipment without the PPE indicated in the work procedures described in these use and warning instructions;
- operate in the presence of open flames or bring open flames close to the work area;
- smoke near the equipment or while working on it;
- use the equipment with parameters other than those indicated on the nameplate;
- use the equipment with fluids other than those indicated on the nameplate and in these use and warning instructions;
- use the equipment outside the operating temperature range specified on the nameplate and in these use and warning instructions;
- service the equipment with the system portion, on which it is installed, running;
- install or use the equipment in environments other than those specified in these instructions for use and warning.

3.5 - SAFETY PICTOGRAMS

The following safety pictograms may be shown on the equipment and/or packaging PIETRO FIORENTINI S.p.A.:

Symbol	Meaning
	Symbol used to identify an ELECTRICAL HAZARD.
	Symbol used to identify a GENERIC HAZARD.

Tab. 3.12

HAZARD!

It is absolutely forbidden to remove the safety pictograms on the equipment.

The user is required to replace the safety pictograms which, following wear, removal or tampering, are illegible.

3.6 - RISK LEVEL

Depending on the operating conditions, use and configuration required, the equipment may generate noise beyond the limits allowed by current legislation in the country of installation.

For the value of the noise generated by the equipment and further information, contact PIETRO FIORENTINI S.p.A.

ATTENTION!

The obligation to use earmuffs or ear plugs to protect the operator's hearing remains in the event that the noise in the installation environment of the equipment (depending on specific operating conditions) exceeds the value of 85 dBA.

4 - DESCRIPTION AND OPERATION

4.1 - GENERAL DESCRIPTION

The DIVAL 600 equipment is a direct acting pressure regulator for medium and low pressure which reduces the inlet gas pressure, keeping the downstream value stable even when the following varies:

- inlet pressure value;
- the required flow rate within the operating conditions of the equipment.

The main elements of the equipment are (see Fig. 4.1.):

Pos.	Description	Pos.	Description
1	Regulator body	7	Upper anti-pumping valve
2	Valve seat	8	Lever mechanism
3	Plug	9	Setting spring
4	Rod	10	Balancing block
5	Main diaphragm	11	Relief spring
6	Lower anti-pumping valve		

Tab. 4.13

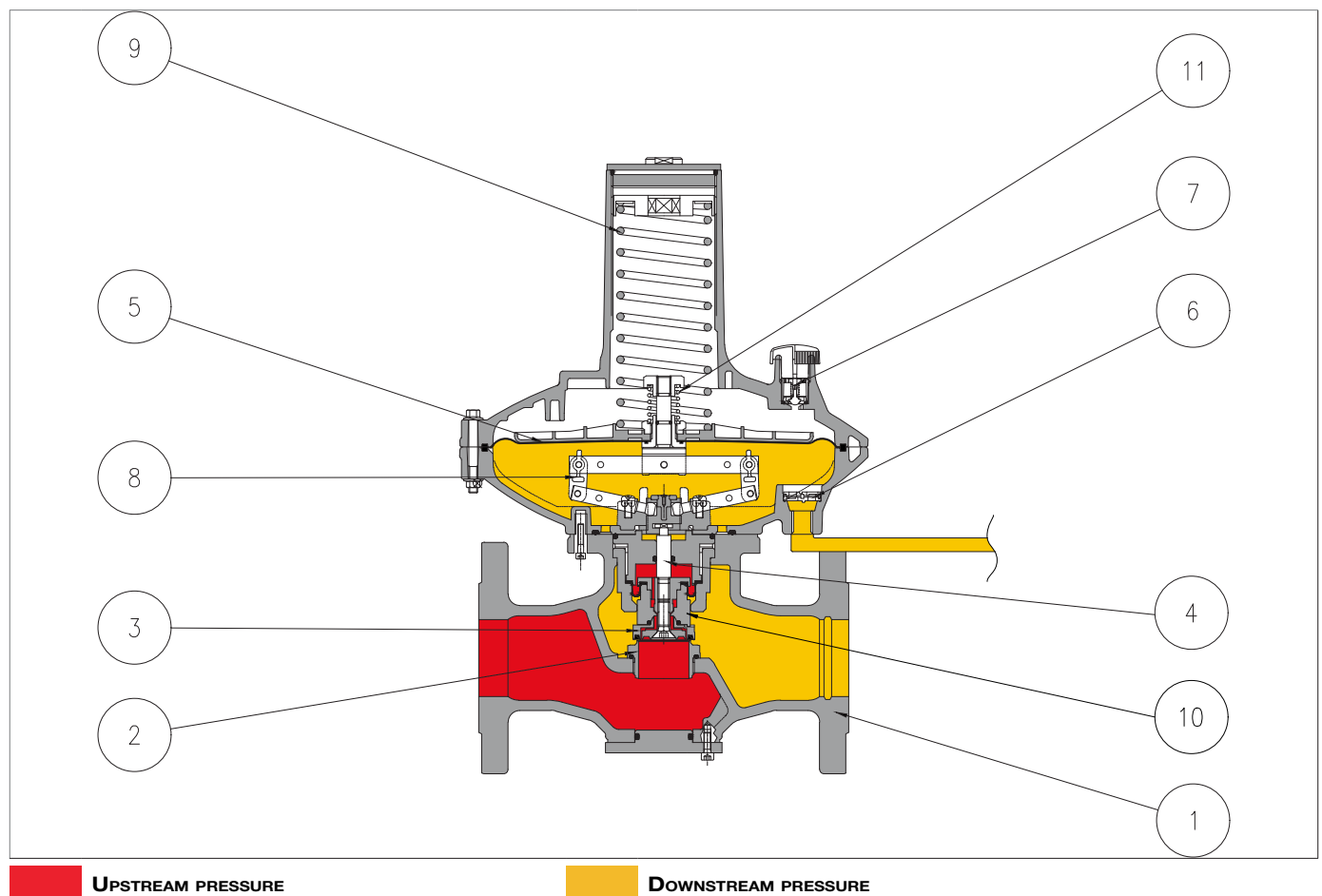

 **UPSTREAM PRESSURE**

 **DOWNSTREAM PRESSURE**

Fig. 4.1. General description DIVAL 600

4.1.1 - REGULATOR REACTION MODES

The DIVAL 600 equipment is a direct acting regulator with a “fail open” reaction (on-opening reaction), that is, it opens in the event of:

- breakage of main diaphragm
- downstream pressure signal missing.

4.2 - OPERATION

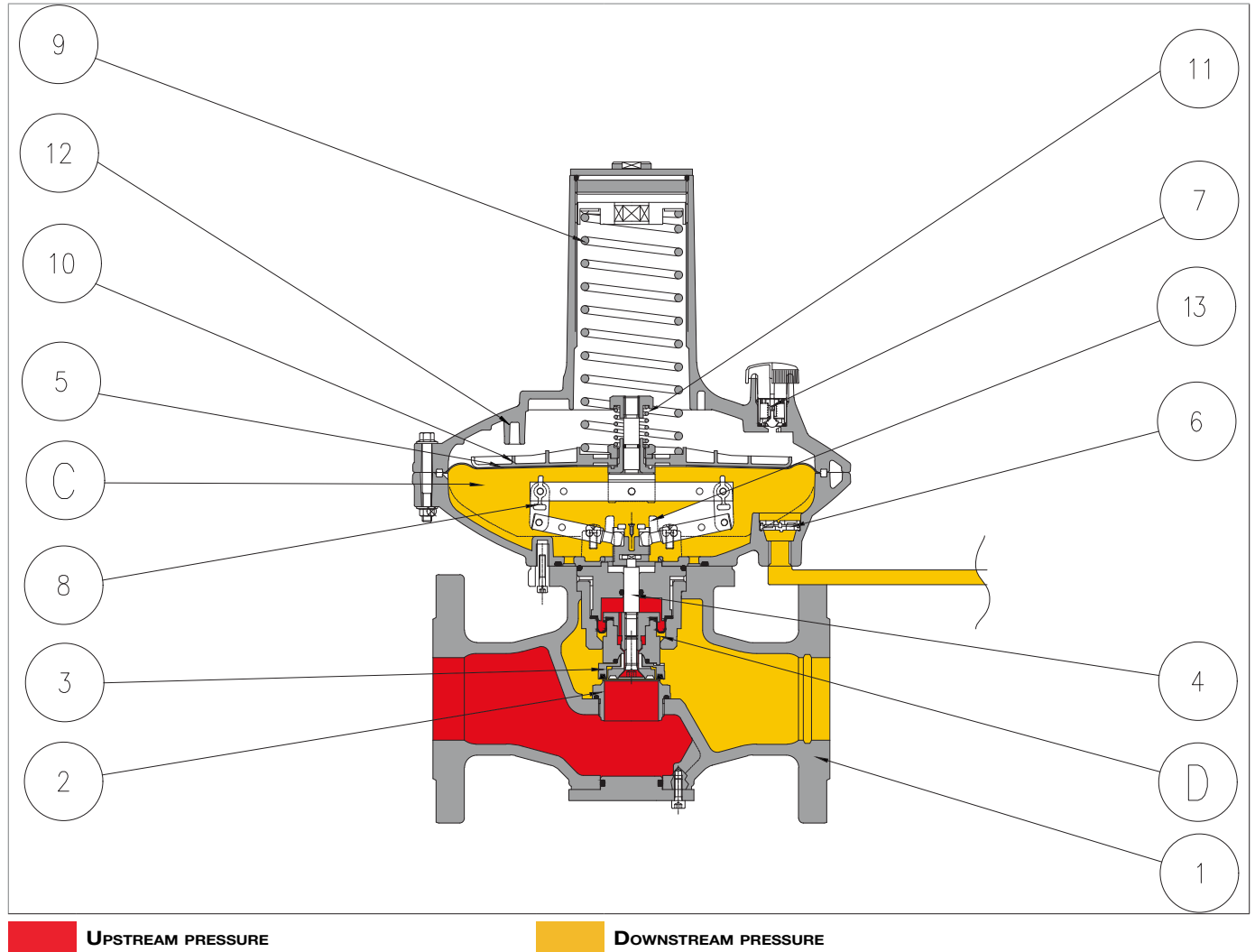

Fig. 4.2. Operation DIVAL 600

In the absence of pressure, the plug (3) is held in the open position by the spring thrust acting on the plug (3) through the engagement of the rod (4) by the lever mechanism (8).

The downstream pressure value (Pd) is regulated by comparing:

- the load of the setting spring (9)
- the thrust that the downstream pressure (Pd) itself exerts on the main diaphragm (5).

The main diaphragm (5) moves the rod (4) and the plug (3). The rod (4) moves perpendicularly with respect to the gas flow. In the case of zero flow, the plug (3) closes on the seat and allows the downstream pressure not to rise above the closing pressure value.

Under normal work conditions, the plug (3) positions itself so as to keep the pressure downstream (Pd) around the pre-established calibration value.

The position of the plug (3) is controlled by the movements of the main diaphragm (5). The forces which affect the position of the plug (3) are:

- towards the closed position: the thrust resulting from the downstream pressure (Pd) in the chamber (C) and in the chamber (D)
- towards the open position: the load of the setting spring (9).

Changes in the upstream pressure (Pu) do not substantially change the value of the downstream pressure (Pd) as the mobile equipment is balanced.

The DIVAL 600 regulator is equipped with two anti-pumping valves (6, 7) located in the sensing line of downstream pressure (Pd) and at the top of the regulator head.

The anti-pumping valves slow down the inflow and outflow of gas in the head during transitional phases. Their function is to minimise the effects caused by quick variations of the requested flow rate (quick variations of the downstream pressure (Pd)) on the behaviour of the regulator.

The limit switches (12, 13) positioned in the regulator head eliminate the effects of possible overpressure below the main diaphragm (5) or overloading of the adjusting spring (9), such as damage to the main diaphragm (5) or excessive load on the plug.

If, during operation, the following should occur:

Operating conditions	Operating consequences	Concluding outcome
<p>Decrease in downstream pressure (Pd) for:</p> <ul style="list-style-type: none"> • increase in the requested flow rate; • drop in pressure upstream (Pu). 	<p>The thrust on the main diaphragm (5) is less than the load on the setting spring (9) and moves the plug (3) towards the open position.</p>	<p>Increase in flow until the preset value of the downstream pressure (Pd) is restored.</p>
<p>Increased downstream pressure (Pd) due to:</p> <ul style="list-style-type: none"> • drop in the requested flow rate; • increase in pressure upstream (Pu). 	<p>The thrust on the main diaphragm (5) is greater than the load on the setting spring (9) and moves the plug (3) towards the closed position.</p>	<p>Decrease in flow rate until the preset value of downstream pressure (Pd) is restored.</p>

Tab. 4.14

4.3 - INTENDED USE

4.3.1 - ENVISAGED USE

The equipment in question is intended for:

Operation	Permitted	Not permitted	Work environment
Adjustment of the downstream pressure for:	Gaseous, and non-corrosive, fluids that have been filtered beforehand.	<ul style="list-style-type: none"> Liquids. Any product other than those permitted. 	Installations for the transport and distribution of gas fuel to supply networks for: <ul style="list-style-type: none"> civil use; industrial use.

Tab. 4.15

The equipment in question is used as a main regulator and in-line monitor regulator.

It was designed to be used exclusively within the limits specified on the nameplate and according to the instructions and limits of use referred to in this manual.

Safe work conditions are as follows:

- use within the limits stated on the nameplate and in this manual;
- compliance with the user manual procedures;
- routine maintenance to be carried out when and how recommended;
- special maintenance to be carried out if required;
- do not tamper with and/or bypass the safety devices.

4.3.2 - REASONABLY FORESEEABLE MISUSE

Reasonably foreseeable misuse means the use of the equipment in a way not foreseen in the design phase but which can result from readily predictable human behaviour:

- corrosive fluids;
- fluids not properly treated upstream;
- liquids;
- instinctive reaction of an operator in the event of a malfunction, accident or breakdown while using the equipment;
- behaviour resulting from pressure to keep the equipment running under all circumstances;
- behaviour resulting from carelessness;
- behaviour resulting from the use of the equipment by unauthorised and unsuitable people;
- using the equipment in a manner other than that referred to under "Envisaged use".

Any use of the equipment other than the intended use must be previously approved in writing by PIETRO FIORENTINI S.p.A. If no written approval is provided, use shall be considered improper.

In the event of "improper use", PIETRO FIORENTINI S.p.A. shall not be held liable for any damage caused to people or property, and any type of warranty on the equipment shall be deemed void.

4.3.3 - TYPES OF FLUIDS

The equipment works with combustible gases used:

- in pressure control stations according to EN 12186 or EN 12279;
- in transmission and distribution networks.
- in commercial and industrial plants (after checking by contacting the Manufacturer).



NOTICE!

The equipment may be also used with inert gases, subject to verification by contacting the manufacturer.

4.4 - TECHNICAL FEATURES/PERFORMANCE

The DIVAL 600 equipment is a regulator for medium and low pressure. The regulation system is balanced and guarantees a stable outlet pressure even when the inlet pressure varies.

The main specifications for this regulator are:

Technical features	
Maximum allowable pressure	Up to 20 bar
Ambient temperature range	-20 °C - +60 °C
Inlet gas temperature range	-20 °C + 60 °C
Inlet pressure range (bpu)	(Pd + 0.1) bar to 20 bar
Possible regulation range (Wd)	0.012 - 4.2 bar
Minimum differential pressure	0.1 bar
Accuracy class (AC)	up to 5 (depending on operating conditions)
Lock up pressure class (SG)	up to 10 (depending on operating conditions)
Connections	<ul style="list-style-type: none"> • Flanged: class 150 RF according to ASME B16.5 and ASME B16.42; PN16, 25 according to ISO 7005-1 and ISO 7005-2 • Threaded: Rp EN 10226-1, NPT ASME B1.20.1 (DN 2" only)

Tab. 4.16

Cg and K1 coefficients						
Heads	Ø280 BP / MP			Ø280 TR		
Size [inches]	1"	1" ½	2"	1"	1" ½	2"
Nominal diameter [mm]	25	40	50	25	40	50
Coefficient Cg	267	698	818	311	749	811
Coefficient K1	94	94	86	97	95	97

Tab. 4.17

4.5 - POSSIBLE CONFIGURATIONS

4.5.1 - CONTROL HEADS

“” lists the possible combinations of sizes and control heads for the equipment DIVAL 600.

		Size [inches] DN [mm]		
		1" 25	1" ½ 40	2" 50
HEADS	BP / MP	Yes	Yes	Yes
	TR	Yes	Yes	Yes

Tab. 4.18

4.5.2 - ACCESSORIES

The DIVAL 600 equipment can have different configurations through the installation of the following accessories:

- Regulator with monitor function
- LA incorporated slam-shut valve.

The possible configurations are listed in “”:

DIVAL 600	Regulator-monitor	LA
Regulator-monitor	-	Yes
LA incorporated slam-shut valve	Yes	-

Tab. 4.19

The accessories can be installed directly at the factory or, at a later time, directly on site.

NOTICE!

The installation of accessories is described in the relevant chapter of this manual.

4.5.3 - REGULATOR WITH MONITOR FUNCTION

The regulator with monitor function (1) is used to keep the downstream pressure value (P_d) within the preset limits in case of failure of the main regulator.

The regulator with monitor function is installed upstream of the main pressure regulator.

The regulator with monitor function has a balancing device designed so that it remains balanced even when the main regulator is in operation.

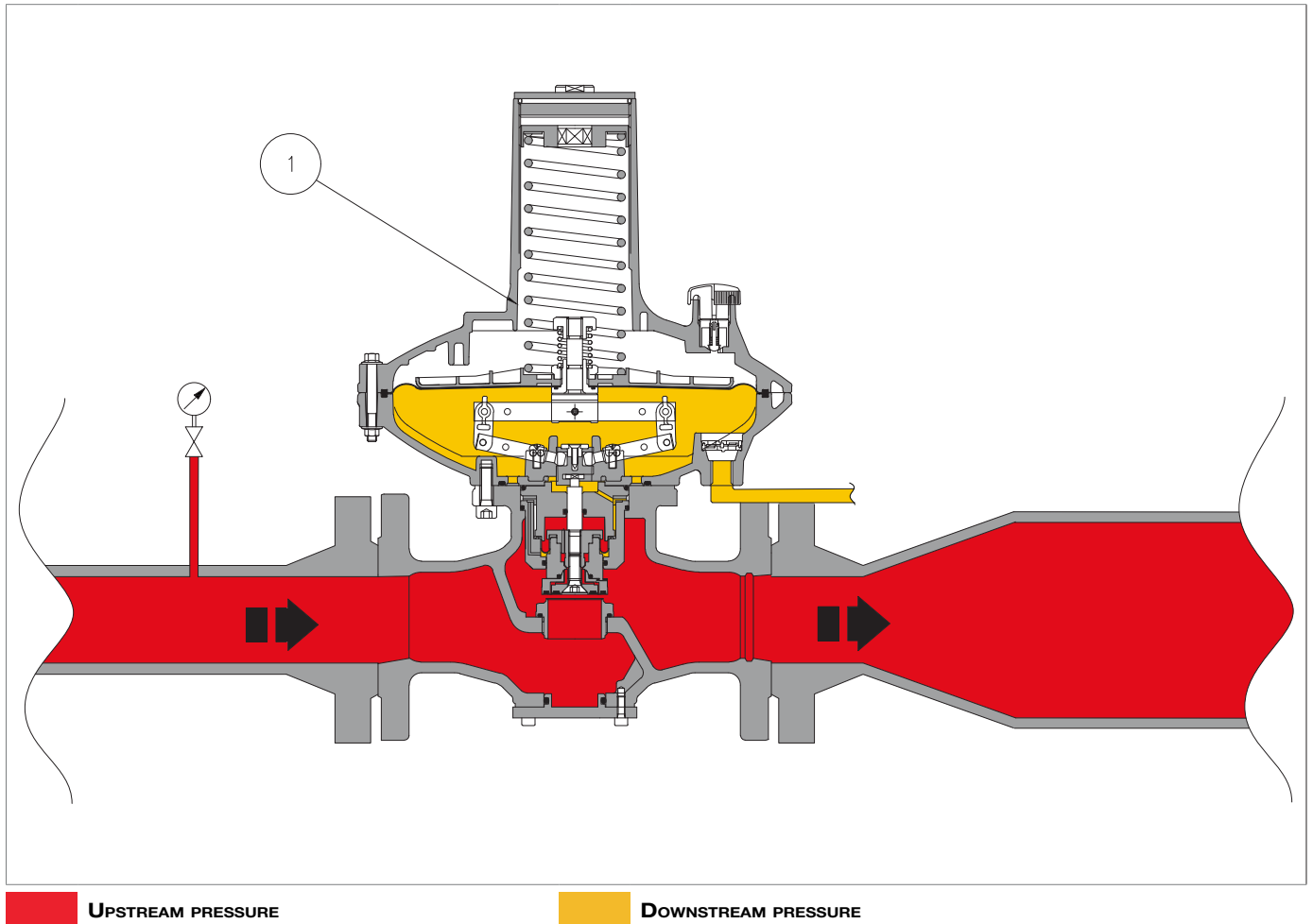

Fig. 4.3. Regulator with monitor function

OPERATION IN STAND-BY CONDITIONS

The regulator with monitor function is open during normal operation since it is calibrated higher than the calibration of the main regulator (2).

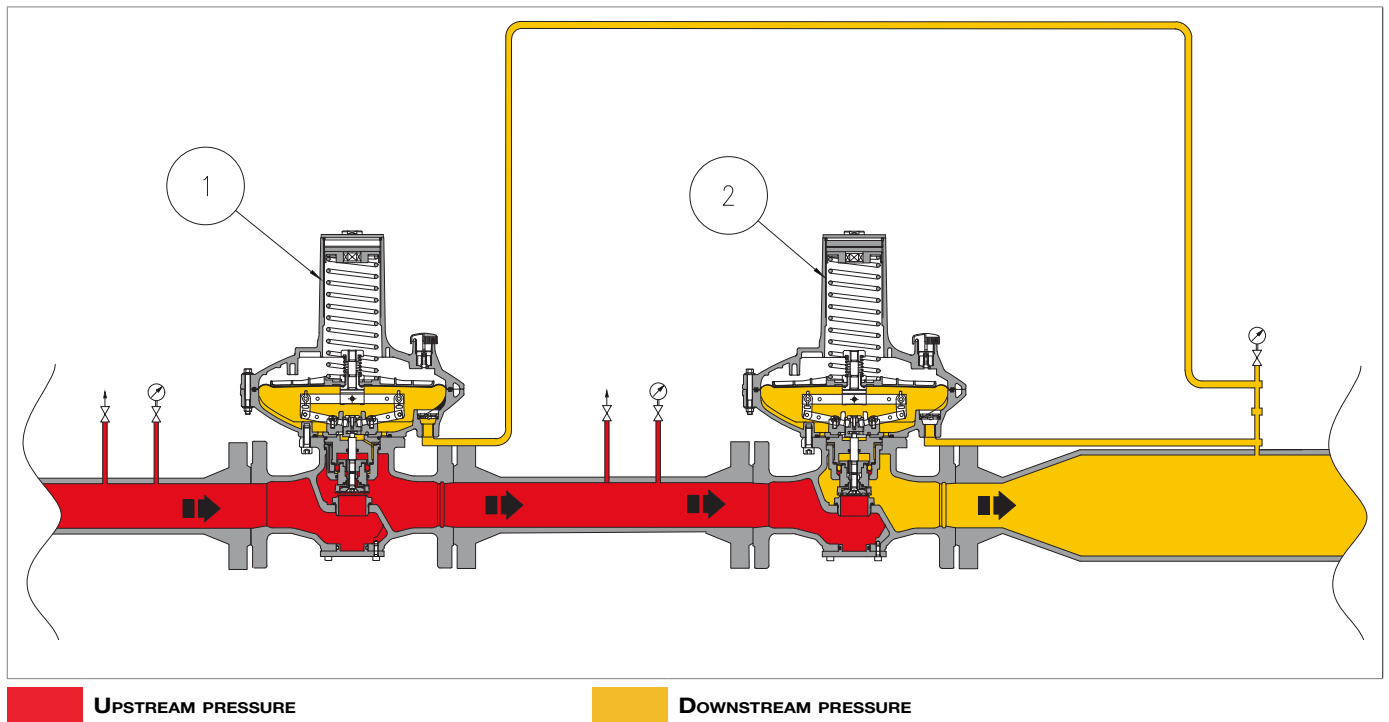

Fig. 4.4. In-line operation of regulator-monitor in stand-by conditions

OPERATION IN THE EVENT OF FAILURE OF THE MAIN REGULATOR

Fig. 4.5. Operation of regulator-monitor with main regulator in faulty conditions

In the event of failure of the main regulator (2), the regulator with monitor function (1) will intervene maintaining the downstream pressure value (P_d) within the established limit for its calibration.

If, during operation, the following should occur:

Operating conditions	Operating consequences	Concluding outcome
Decrease in downstream pressure (P_d) for: <ul style="list-style-type: none"> • increase in the requested flow rate; • drop in pressure upstream (P_u). 	Unbalance that causes the plug (3) to open.	Increase in flow until the preset value of the downstream pressure (P_d) is restored.
Increased downstream pressure (P_d) due to: <ul style="list-style-type: none"> • drop in the requested flow rate; • increase in pressure upstream (P_u). 	Unbalance that causes the plug (3) to close.	Decrease in flow rate until the preset value of downstream pressure (P_d) is restored.

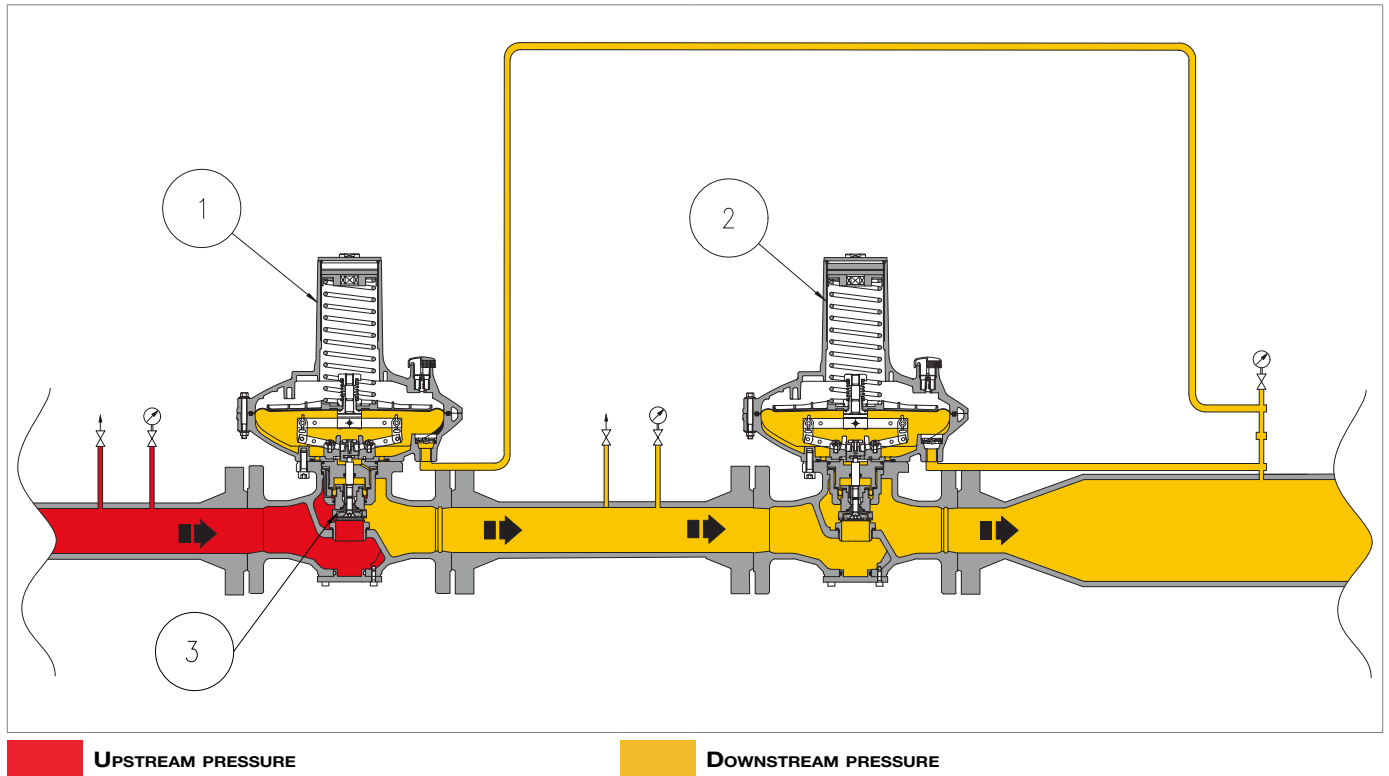
Tab. 4.20

4.5.4 - SLAM-SHUT VALVE

The slam-shut valve is a safety device is used to shut off the gas flow if the pressure value at the control point exceeds the calibration value of the valve itself.

The slam-shut valve incorporated in the regulator consists of:

- a control system;
- the slam-shut device mechanism.

In the event of tripping, the slam-shut valve shuts off the supply to the regulator.

4.5.4.1 - LA INCORPORATED SLAM-SHUT VALVE

The LA incorporated slam-shut valve can be operated:

- by the intervention spring
- manually.

The main features of the LA incorporated slam-shut valve are:

- tripping due to downstream pressure increase and/or decrease;
- design pressure: 20 bar for all accessory components;
- local close button (can be omitted on request).

Slam-shut valve type		Set	Operating range (bar)	AG
LA	BP	max	0.03 - 0.18	10
		min	0.006 - 0.06	30
LA	MP	max	0.14 - 0.179	10
			0.18 - 0.45	5
		min	0.01 - 0.059	30
			0.06 - 0.24	10
LA	TR	max	0.25 - 1.29	10
			1.3 - 5.5	5
		min	0.1 - 3.5	10

Tab. 4.21

The incorporated LA slam-shut valve consists of (see fig. 4.6):

Pos.	Description	Pos.	Description
1	Plug pad	6	Tripping spring due to pressure increase
2	Reset knob	7	Tripping spring due to pressure decrease
3	Coupling device	8	Spring support
4	Rod	9	Control shaft
5	Diaphragm	10	Sensor

Tab. 4.22

OPERATION

In the control head (C), the downstream pressure (Pd) acts on the diaphragm (5), which, integral with the control shaft (9), receives an antagonistic force via the springs (6, 7), which causes the pressure to rise or fall.

In the event of tripping due to a pressure surge:

- the downstream pressure (Pd) exceeds the calibration value
- the load on the diaphragm (6) increases until the resistance of the spring (6) is overcome
- movement to the open position of the drive shaft (9) moves the touch probe (10) via the cam, disengaging the lever mechanism.

In the event of a tripping due to pressure drop:

- the downstream pressure (Pd) drops below the calibration value
- the spring holder (7) stops the stroke
- movement to the closed position of the drive shaft (9) moves the touch probe (10) via the cam, disengaging the lever mechanism.

To reset the LA slam-shut valve:

- pull the reset knob (2) downwards until the lever mechanism is reengaged
- wait for the upstream pressure (Pu) to pass downstream of the plug (1), balancing it
- press the reset knob (2) into its seat.

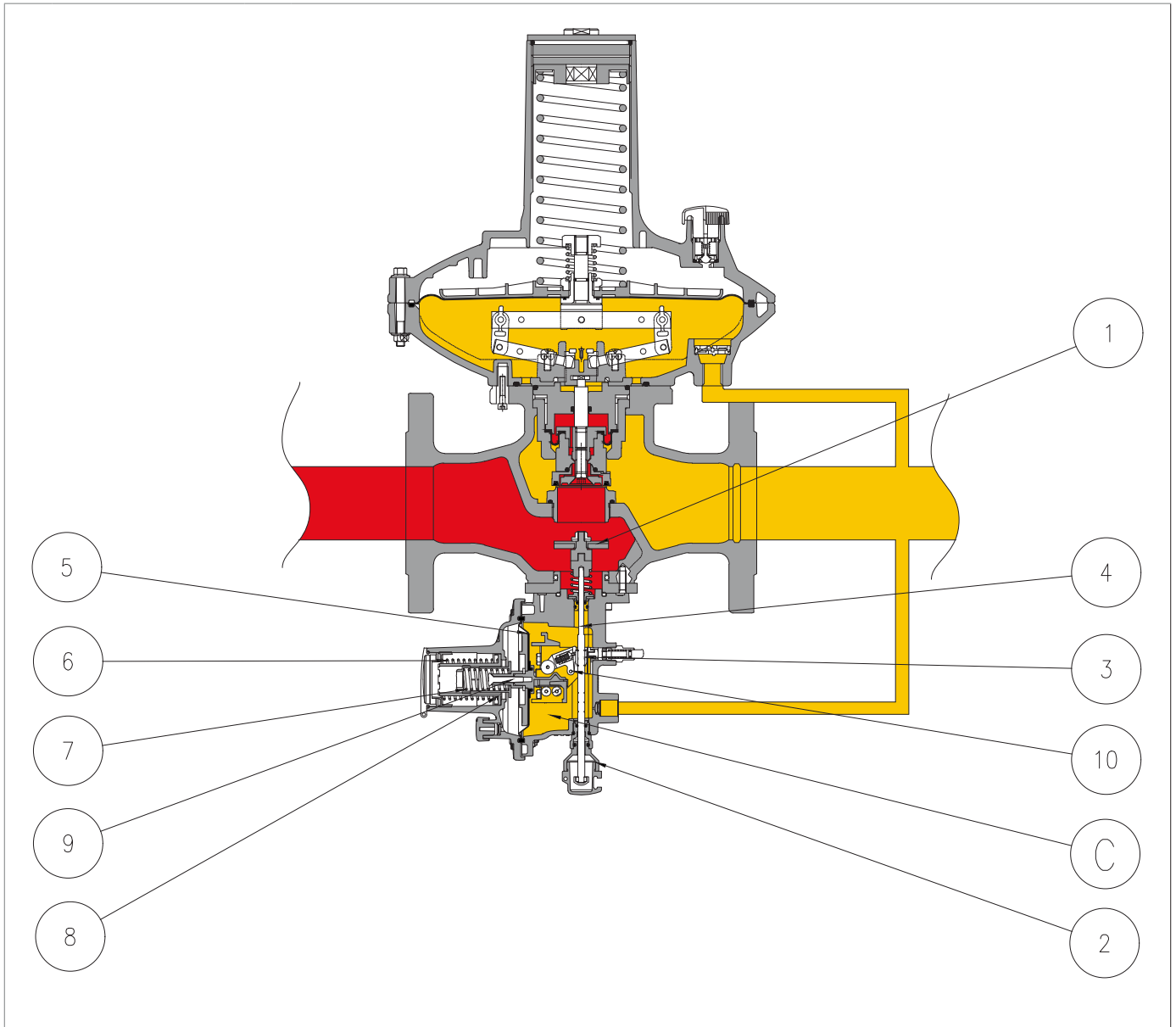

UPSTREAM PRESSURE **DOWNSTREAM PRESSURE**

Fig. 4.6. DIVAL 600 with incorporated LA slam-shut valve

5 - TRANSPORT AND HANDLING

5.1 - SPECIFIC WARNINGS FOR TRANSPORT AND HANDLING

NOTICE!

Transport and handling must be carried out by personnel:

- qualified (specially trained);
- who are familiar with accident prevention and workplace safety regulations;
- authorised to use lifting equipment;
- in compliance with the regulations in force in the country of destination of the equipment.

Transport with forklift or crane

Operator qualification	Person in charge of transport, handling, unloading and placing on site
PPE required	 <p>WARNING!</p> <p>The PPE listed in this table is related to the risk associated with the equipment. For the PPE required to protect against risks associated with the workplace, installation or operating conditions, please refer to:</p> <ul style="list-style-type: none"> • the regulations in force in the country of installation; • <u>any information provided by the Safety Manager at the installation facility.</u>
Lifting equipment	Hoist crane, forklift truck or other suitable equipment.
Weights and dimensions of the equipment	For dimensions and weights please refer to "Physical characteristics of the equipment".

Tab. 5.23

5.1.1 - PACKAGING AND FASTENERS USED FOR TRANSPORT

The transport packaging is designed and manufactured to avoid damage during normal transport, storage and handling. The equipment and spare parts must be kept in their packaging until they are installed.



Upon receiving the equipment:

- make sure that no part has been damaged during transport and/or handling;
- immediately report any damage found to PIETRO FIORENTINI S.p.A..

! NOTICE!

PIETRO FIORENTINI S.p.A. shall not be liable for any damage to people or property caused by accidents due to failure to comply with the instructions provided in this manual.

“” shows the types of packaging used:

Ref.	Type of packaging	Image
A	Cardboard box	
B	Wooden box	
C	Pallet	

Tab. 5.24

5.2 - PHYSICAL CHARACTERISTICS OF THE EQUIPMENT

5.2.1 - DIVAL 600

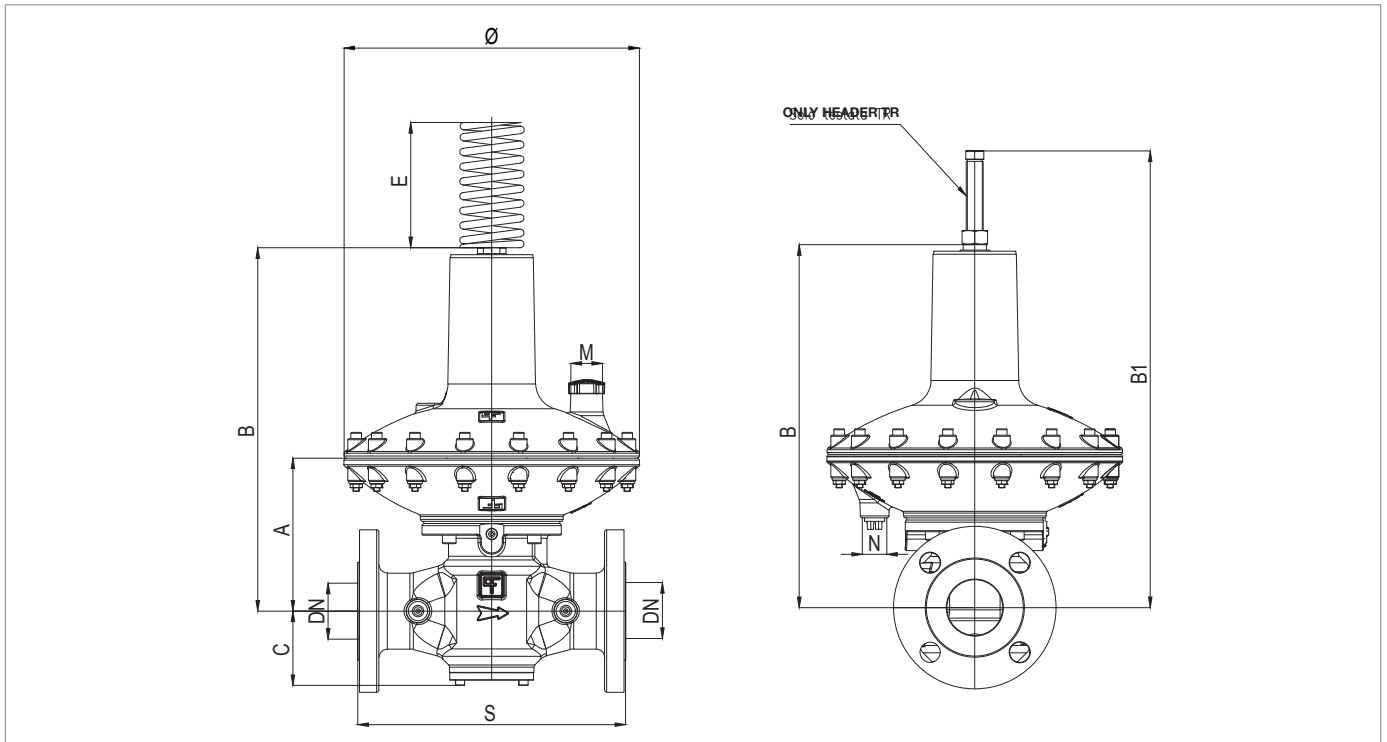

Fig. 5.7. DIVAL 600 physical characteristics

DIVAL 600 overall dimensions				
Size [inches]	1"	1" ½	2"	2" NPT
Nominal diameter [mm]	25	40	50	G 2"
S	183	222	254	152.4
Ø	280	280	280	280
A	145	145	145	145
B	346	346	346	346
B1	472	472	472	472
C	65	70	70	70
E	180	180	180	180
M	Rp 1/2"	Rp 1/2"	Rp 1/2"	Rp 1/2"
N	Rp 1/4"	Rp 1/4"	Rp 1/4"	Rp 1/4"
Connecting pneumatic connections	eØ 10mm x Øi 8mm			

Tab. 5.25

DIVAL 600				
Weight [kgf]	14	17.5	18.5	13.8

Tab. 5.26

5.2.2 - DIVAL 600 + LA

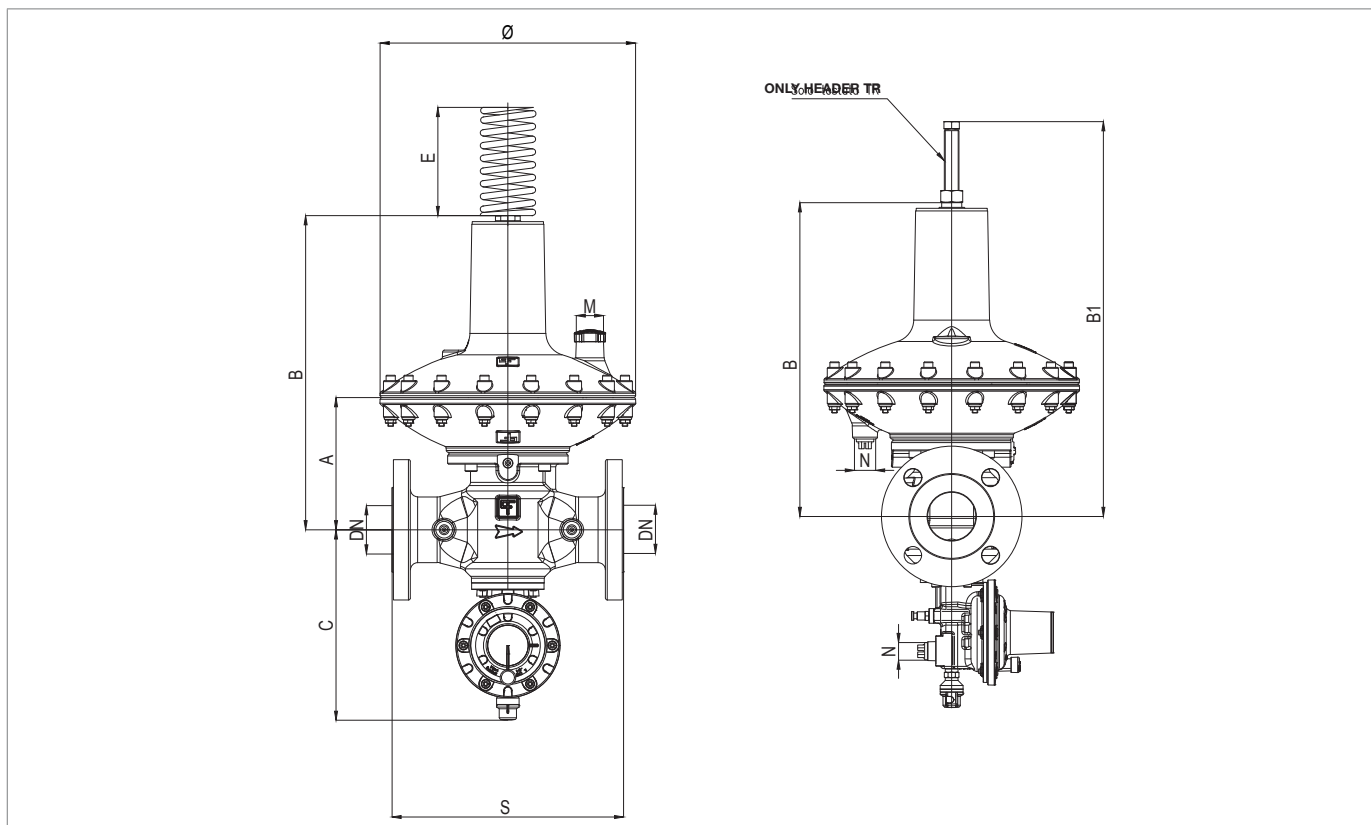

Fig. 5.8. Physical characteristics DIVAL 600 + LA

Overall dimensions DIVAL 600 + LA				
Size [inches]	1"	1" ½	2"	2" NPT
Nominal diameter [mm]	25	40	50	G 2"
S	183	222	254	152.4
Ø	280	280	280	280
A	145	145	145	145
B	346	346	346	346
B1	472	472	472	472
C	198	210	210	210
E	180	180	180	180
M	Rp 1/2"	Rp 1/2"	Rp 1/2"	Rp 1/2"
N	Rp 1/4"	Rp 1/4"	Rp 1/4"	Rp 1/4"
Connecting pneumatic connections	eØ 10mm x Øi 8mm			

Tab. 5.27

DIVAL 600 + LA				
Weight [kgf]	14.8	18.5	19.5	14.8

Tab. 5.28

5.3 - EQUIPMENT ANCHORING AND LIFTING METHOD

 **HAZARD!**

Before moving the equipment, make sure that the capacity of the lifting equipment is suitable for the load.

 **WARNING!**

Unloading, transport and handling activities must be carried out by operators qualified and specially trained:

- on accident prevention rules;
- on maximum safety in the workplace;
- on the use of lifting equipment.

 **ATTENTION!**

Before moving the equipment:

- remove any movable or hanging component or firmly secure it to the load;
- protect fragile equipment;
- check that the load is stable.

5.3.1 - FORKLIFT HANDLING METHOD

HAZARD!

It is forbidden to:

- Do not transit under suspended loads;
- Do not move the load over the personnel operating in the site/plant area.

WARNING!





The following is not allowed on forklifts:

- carrying passengers;
- lifting people.

NOTICE!

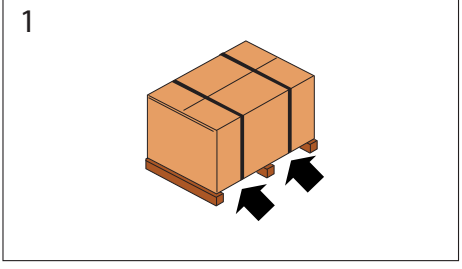
Packaging must always be handled in a vertical position

Proceed as described at “”:

Step	Action	Image
1	Place the forks of the forklift under the load surface.	<p>1</p> 
2	Make sure that the forks protrude from the front of the load (by at least 5 cm), far enough to eliminate any risk of the transported load tipping.	<p>2</p> 
3	<p>Raise the forks until they are touching the load.</p> <div style="border: 1px solid blue; padding: 5px; margin-top: 10px;"> <p>NOTICE! Fasten the load to the forks with clamps or similar devices if required.</p> </div>	<p>3</p> 
4	Slowly lift the load by a few dozen centimetres and check its stability, making sure that the centre of gravity of the load is positioned at the centre of the lifting forks.	<p>4</p> 

DIVAL 600

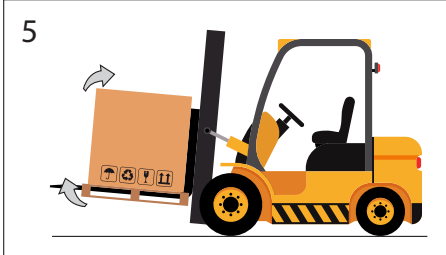
Step	Action	Image
5	Tilt the mast backwards (towards the driver's seat) to help the over-turning moment and to ensure greater load stability during transport.	
6	Adjust transport speed according to the type of floor and load, avoiding sudden manoeuvres. ⚠ WARNING! In case of: <ul style="list-style-type: none"> • obstacles along the path; • particular operating situations; hinder operator visibility, the assistance of a ground operator is required, standing outside the range of action of the lifting equipment, with the task of signalling.	-
7	Place the load in the chosen installation area.	-

Tab. 5.29

5.3.2 - CRANE HANDLING METHOD

⚠ WARNING!

It is mandatory to use CE marked chains, ropes and eyebolts or marked with conformity marks/markings in accordance with the regulations in force in the place of installation. Do not use chains connected to each other by bolts.

Always check that:

- the safety catch of the hook returns to the initial position;
- the ropes are in excellent condition and have adequate sections.

It is forbidden to:

- drag the load on the ground;
- operate near power lines;
- stand within the range of action of the crane.

! NOTICE!

Packaging must be always handled in a vertical position.

The equipment must be handled using the lifting points provided on the equipment itself. For proper transport, follow the procedure in “”:

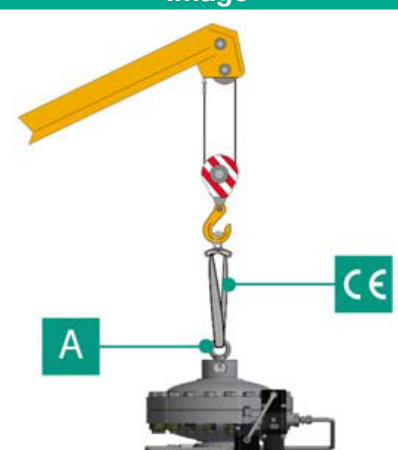
Step	Action	Image
1	Attach the lifting rope or chain to the appropriate supports. <div style="background-color: #f4a460; padding: 5px; margin-top: 5px;"> ⚠ WARNING! The lifting point is sized for lifting only the equipment, and not other parts of the system connected to it. </div>	
2	Slightly lift the load making sure the ropes or chains are secure. <div style="border: 1px solid #0070c0; padding: 5px; margin-top: 5px;"> ! NOTICE! Check whether the load is properly balanced. </div>	
3	Handle the load avoiding sudden movements.	
4	Place the load in the chosen installation area.	

Tab. 5.30

5.4 - PACKAGING REMOVAL

Packaging removal	
Operator qualification	<ul style="list-style-type: none"> Person in charge of transport, handling, unloading and placing on site; Installer.
PPE required	<div style="display: flex; align-items: center;">  </div> <div style="background-color: #f4a460; padding: 5px; margin-top: 5px;"> ⚠ WARNING! </div> <p>The PPE listed in this table is related to the risk associated with the equipment. For the PPE necessary to protect against risks associated with the workplace or operating conditions, please refer to:</p> <ul style="list-style-type: none"> the regulations in force in the country of installation; <u>any information provided by the Safety Manager at the installation facility.</u>

Tab. 5.31

To unpack the equipment in a cardboard box, proceed as described in “”:

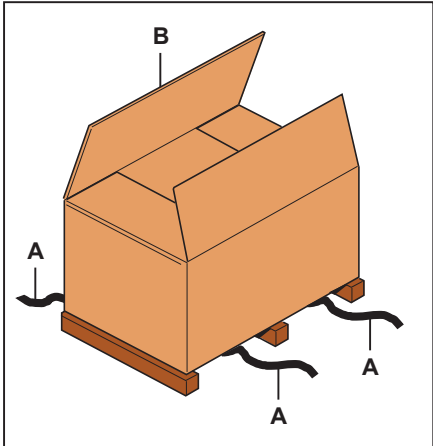
Step	Action	Image
1	Remove the straps (A).	
2	Remove the packaging cardboard (B).	
3	Remove the fasteners that secure the equipment to the base (if any).	
4	Move the equipment from the base to the place intended for it. <div style="border: 1px solid blue; padding: 5px; margin-top: 5px;"> ⚠ NOTICE! Have at least 2 operators manually move the equipment, if required due to its dimensions/weight. </div>	

Tab. 5.32

⚠ NOTICE!

After removing all packaging materials, check for any anomalies.

If there are anomalies:

- do not install the equipment;
- contact PIETRO FIORENTINI S.p.A. and specify the details provided on the equipment nameplate.

5.4.1 - PACKAGING DISPOSAL

⚠ NOTICE!

Sort the various materials making up the packaging and dispose of them in compliance with the regulations in force in the country of installation.

5.5 - STORAGE AND ENVIRONMENTAL CONDITIONS

If the equipment needs to be stored for an extended period, the minimum environmental conditions for the intended storage are provided. Only by complying with these requirements can the declared performance be guaranteed:

Conditions	Data
Maximum storage period	Maximum 3 years. <div style="border: 1px solid blue; padding: 5px;">  NOTICE! For installations in later periods, see paragraph “Pre-installation warnings after prolonged storage”. </div>
Temperature	Not above 40°C
Humidity	Not above 70%
Radiation	Away from radiation sources according to UNI ISO 2230:2009

Tab. 5.33

5.5.1 - PRE-INSTALLATION WARNINGS AFTER PROLONGED STORAGE

For installations that have been stored for longer than 3 years, the condition of all rubber parts must be checked and, if found to be damaged, they must be replaced in order to ensure the correct functioning of the equipment.

For the replacement of the rubber parts of the equipment, please refer to “General warnings”.

<div style="border: 1px solid blue; padding: 5px;">  NOTICE! PIETRO FIORENTINI S.p.A. recommends checking the condition of rubber parts in case of downtime or storage longer than 3 years. </div>
--

6 - INSTALLATION

6.1 - INSTALLATION PRE-REQUISITES

6.1.1 - ALLOWED ENVIRONMENTAL CONDITIONS

WARNING!

To safely use the equipment, in full respect of the allowed environmental conditions, follow the data shown on the regulator plate and on any accessories (refer to paragraph “2.8 - Nameplates applied”).

The installation site must be suitable for the safe use of the equipment.

The installation area of the equipment must be properly lit to ensure proper operator visibility during working on the equipment.

NOTICE!

The equipment must operate in places that are properly lit by artificial lighting suitable for the protection of the operator (in compliance with UNI EN 12464-1:2011 and UNI EN 12464-2:2014). If maintenance work is to be performed in areas and/or parts that are poorly lit, it is mandatory to:

- use all the light sources of the installation plant;
- be equipped with a handheld lighting system or connected to the power mains, compliant with Directive 2014/34/EU (ATEX) for use in environments at risk of explosion.

6.1.2 - CHECKS BEFORE INSTALLATION

The equipment does not require any further upstream safety device for protection against any overpressure with respect to its **PS admissible pressure** when, for the upstream reduction station, the maximum incidental downstream pressure is:

$$\text{MIPd} \leq 1.1 \text{ PS}$$

MIPd = Maximum incidental downstream pressure value (for further information, see UNI EN 12186:2014).

ATTENTION!

If the installation of the equipment requires the application of compression fittings, these must be installed in accordance with the instructions of the Manufacturer of the fittings themselves.



The choice of fittings must be compatible with:

- **the use specified for the equipment;**
- **the plant specifications when required.**

Before installation, it must be ensured that:

- the expected dimensions of the installation site are compatible with those of the equipment;
- there are no impediments for the workers in charge of maintenance;
- the upstream and downstream pipes are at the same level and can bear the weight of the equipment;
- the inlet and outlet connections of the pipes are aligned on the flanges;
- the inlet and outlet connections of the equipment are clean and flawless;
- the inside of the upstream pipe is clean and free of processing residues such as welding slag, sand, paint residues, water, etc...

Installation

Operator qualification	Installer
PPE required	 <p> WARNING!</p> <p>The PPE listed in this table is related to the risk associated with the equipment. For the PPE required to protect against risks associated with the workplace, installation or operating conditions, please refer to:</p> <ul style="list-style-type: none"> • the regulations in force in the country of installation; • any information provided by the Safety Manager at the installation facility.
Equipment required	Please refer to the chapter "Commissioning/maintenance equipment".

Tab. 6.34

6.2 - SPECIFIC SAFETY INSTRUCTIONS FOR THE INSTALLATION STEP

 **WARNING!**

Before proceeding with installation, make sure that the upstream and downstream valves installed on the line are shut off.

 **WARNING!**

Installation may also take place in areas where there is a risk of explosion, which implies that all necessary prevention and protection measures have to be taken.

For these measures, please refer to the regulations in force at the place of installation.

6.3 - GENERAL INFORMATION ON CONNECTIONS

The equipment must be installed in-line with an arrow on the body pointing to the gas flow direction.
In line installation, there must be (see Fig. 6.9 and 6.10):

Pos.	Description
1	1 shut-off valve upstream of the equipment.
2	2 vent valves one upstream and one downstream of the equipment.
3	2 pressure gauges one upstream and one downstream of the equipment.
4	1 pressure regulator .
5	1 shut-off valve downstream of the equipment.

Tab. 6.35

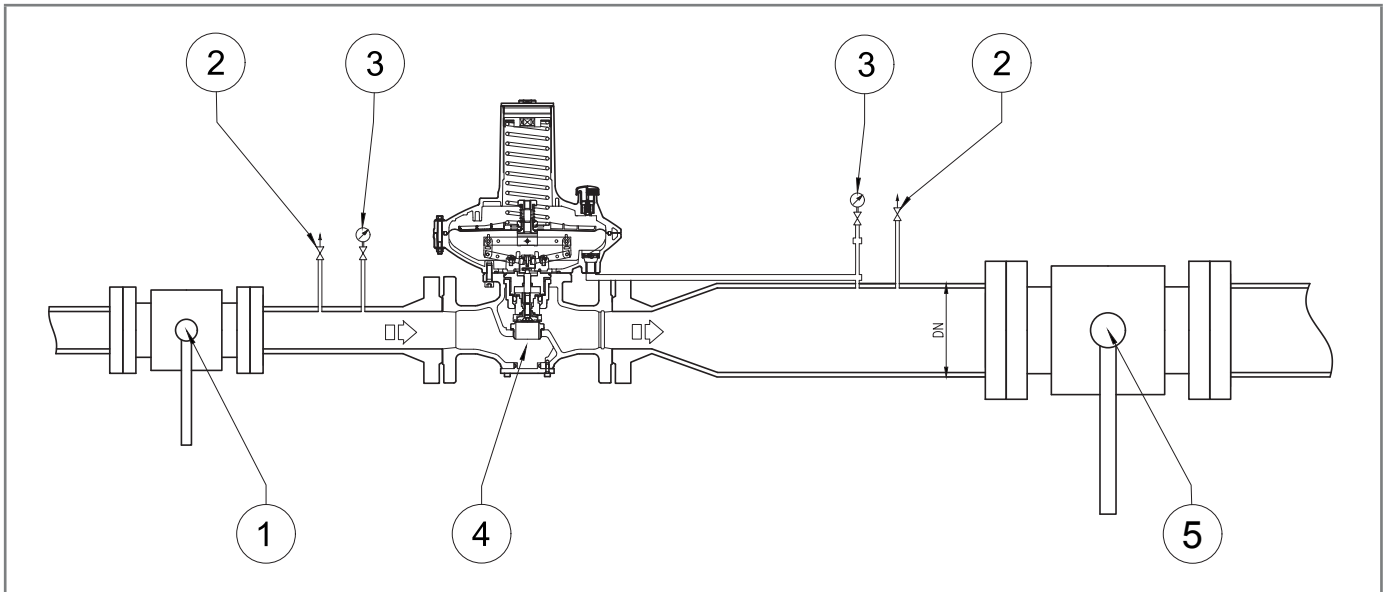

Fig. 6.9. In-line installation

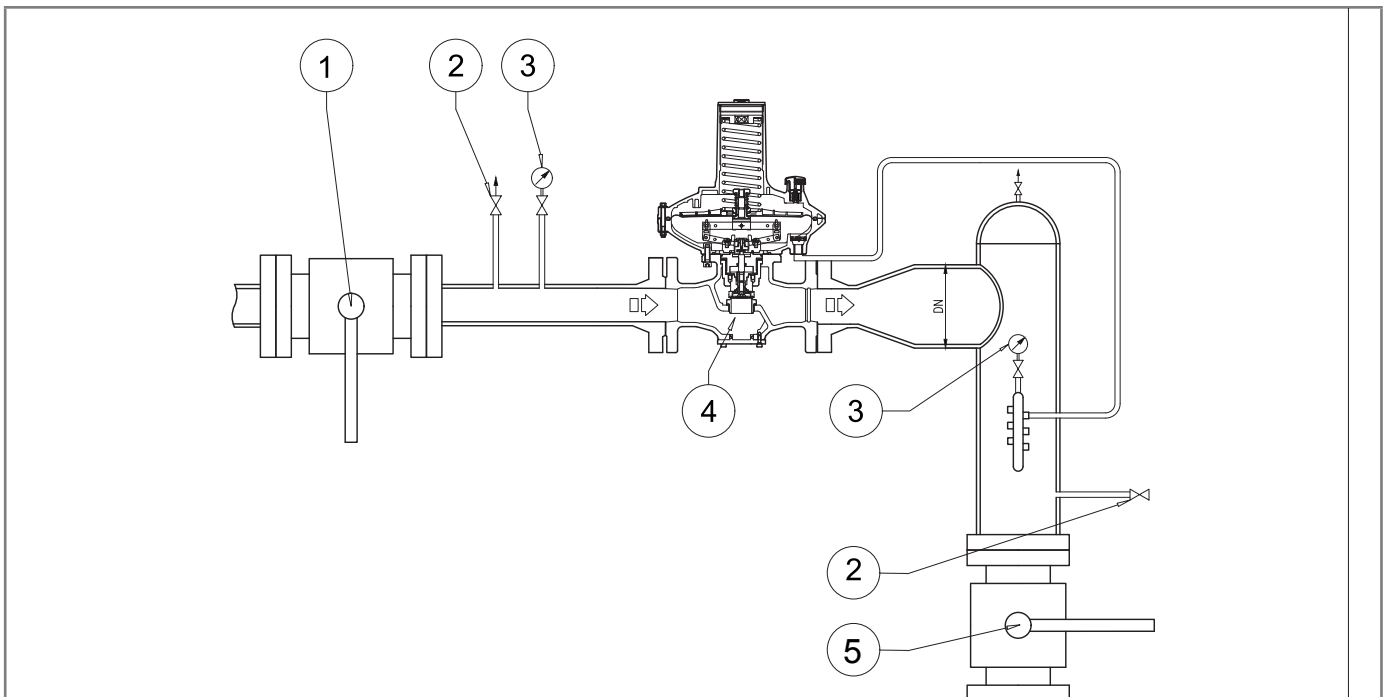

Fig. 6.10. Angle installation

! NOTICE!

When used in gas pressure reduction stations, the device must be installed at least according to the requirements of standards UNI EN 12186:2014 or UNI EN 12279:2007.

Equipment vents must be ducted in accordance with UNI EN 12186:2014 or UNI EN 12279:2007 or the standards in force at the place of installation of the equipment.

6.4 - REGULATOR INSTALLATION POSITIONS

Figure 6.11 and 6.12 illustrate typical regulator arrangements:

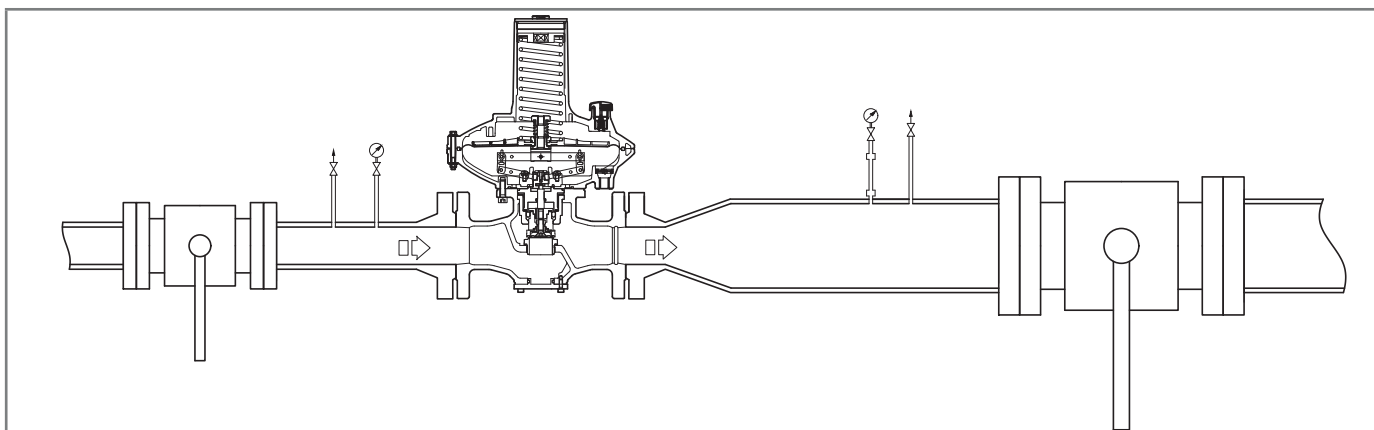

Fig. 6.11. Standard position

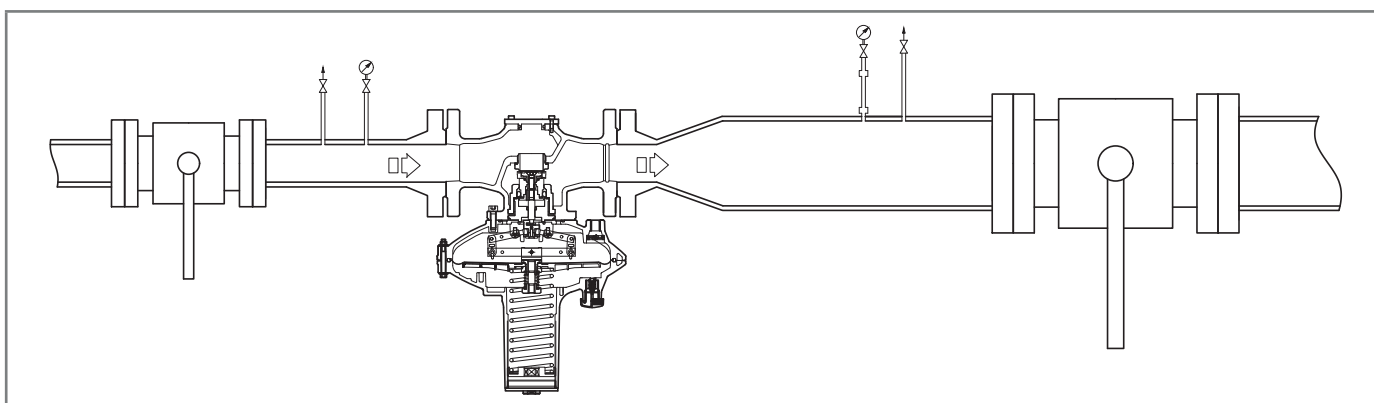

Fig. 6.12. Inverted position

6.5 - INSTALLATION PROCEDURES

6.5.1 - EQUIPMENT INSTALLATION PROCEDURES

Step	Action
1	Place the equipment in the section of the line designated for it.
2	Place the gaskets between the line flanges and the regulator flanges.
3	Insert the bolts into the appropriate holes of the connecting flanges.
4	Screw the bolts following the technical rules for tightening flanges.

Tab. 6.36

NOTICE!

For installation after maintenance, replace the seals.

6.5.2 - CONNECTION OF THE SENSING LINES TO THE DOWNSTREAM PIPING

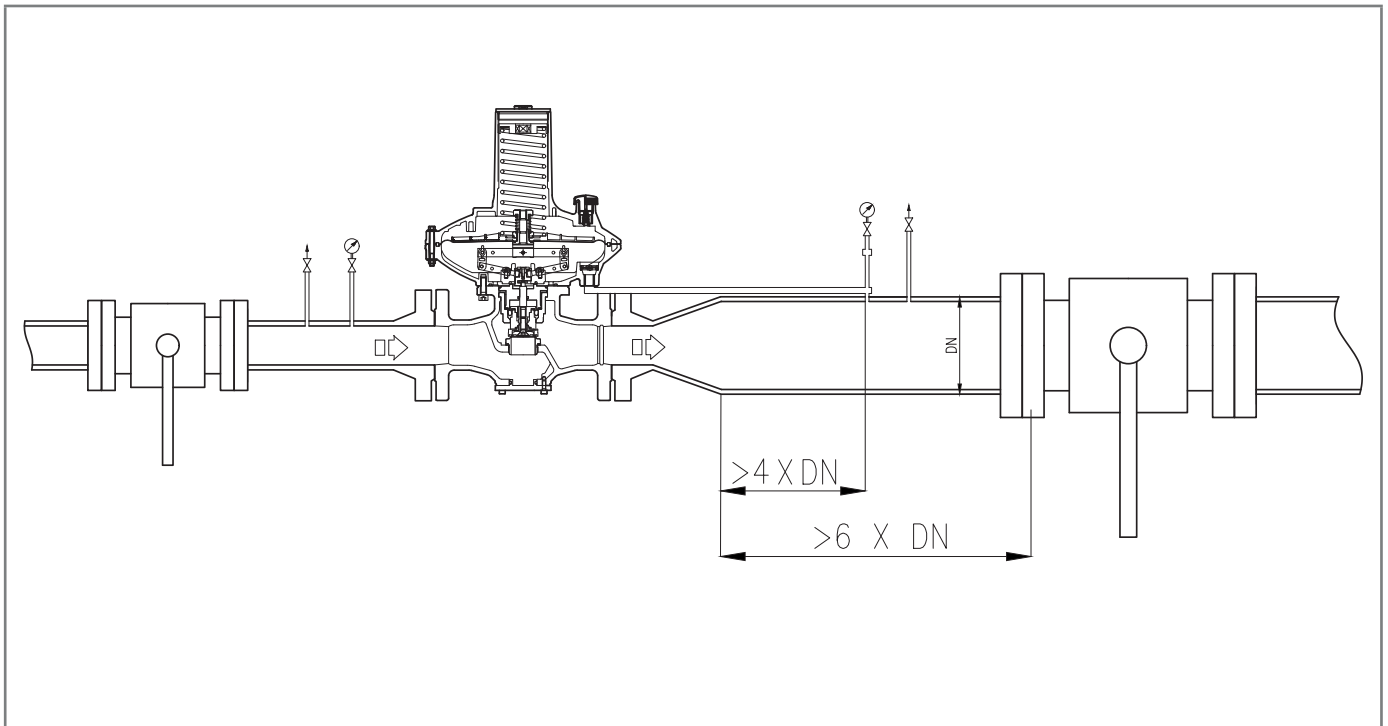

Fig. 6.13. Connection of sensing lines to the downstream piping

For proper adjustment, it is essential that:

- the downstream shut-off valve is placed at a distance of at least 6 times the nominal diameter of the pipe downstream of the regulator;
- the downstream sensing lines are placed on a straight section of pipe (with uniform diameter) having a length equal to at least 4 times the nominal diameter of the piping itself;

For optimum performance, the velocity of the pressurised fluid at the sampling point does not exceed the following values:

$V_{max} = 30 \text{ m/s}$ for $P_a > 5 \text{ bar}$

$V_{max} = 25 \text{ m/s}$ for $P_a < 5 \text{ bar}$

As a limit for use, the velocity of the fluid under pressure at the point of pick-up does not exceed the following value:

$V_{max} = 40 \text{ m/s}$ for $P_a > 5 \text{ bar}$

To calculate the flow rate, use the following formula:

$$V = 345,92 \times \frac{Q}{DN^2} \times \frac{1 - 0,002 \times Pd}{1 + Pd}$$

V = gas velocity in m/sec

Q = gas flow rate Stm³/h

DN = nominal pipe diameter in mm

Pd = regulator outlet pressure in barg

! NOTICE!

All on-site pneumatic connections must have pipes with a minimum internal diameter of 8 mm.

To prevent the pneumatic connections of the sensing lines from collecting impurities and condensation, it is necessary that:

- the connections of the pneumatic connection are always welded to the top or horizontal axis of the pipe itself (refer to Fig. 6.14);
- the hole in the piping has no burrs or internal protrusions;
- the slope of the pneumatic connection is always 5-10% towards the downstream pipe connection.

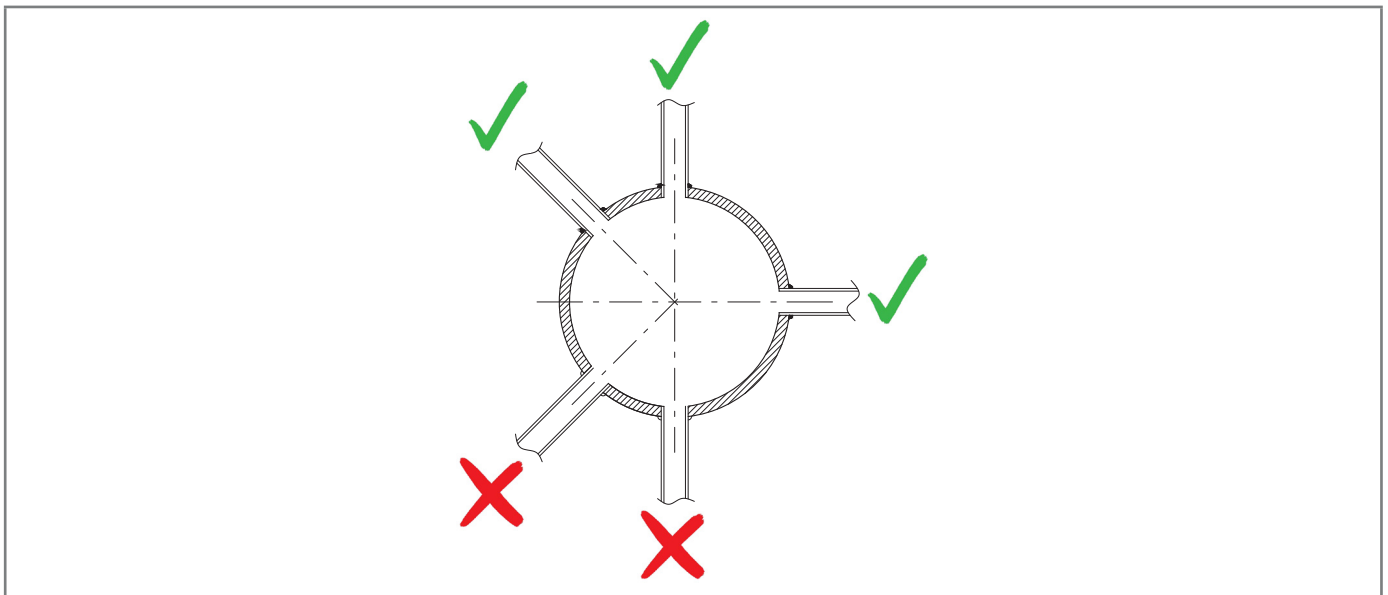

Fig. 6.14. Welded pipe connections

If there is a multiple sensing line, connect the equipment connections as shown below:

- 1 and 2 to the discharge outlet of the regulator control head and of the regulator in monitor function (when present);
- 3 and 4 free sensing lines;
- 5 and 6 to the sensing lines of the slam-shut valve (when present).

! NOTICE!

**If there is a multiple sensing line, it is not recommended to place shut-off valves on sensing lines.
In any case, follow the regulations in force in the place of installation and use of the equipment.**

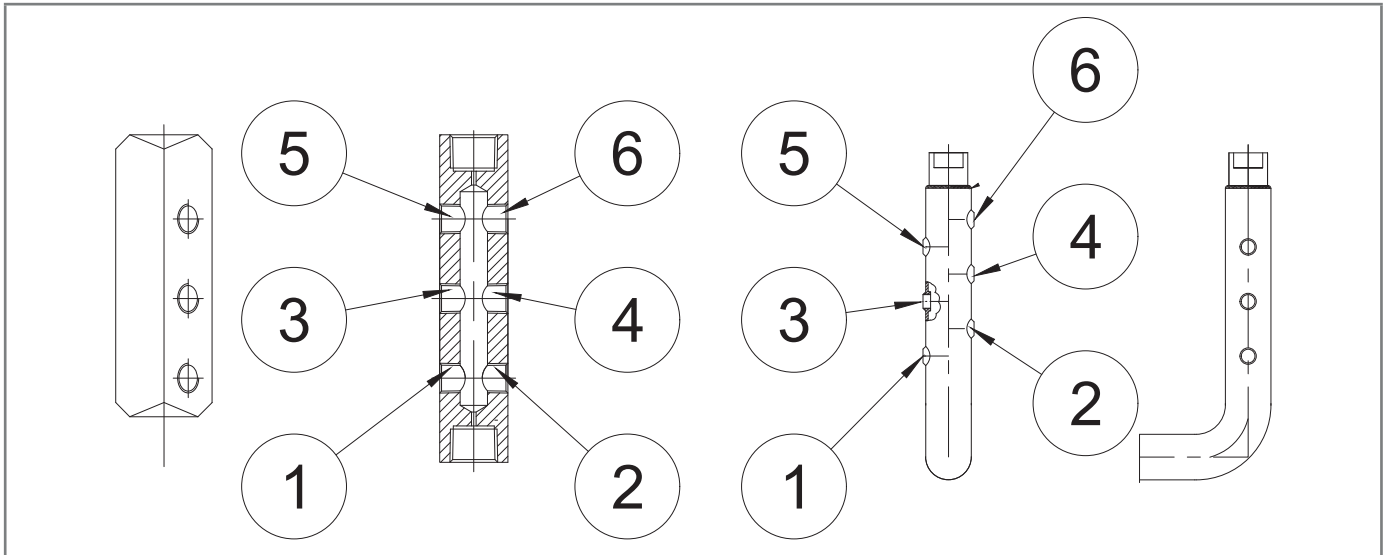

Fig. 6.15. Equipment connections

6.6 - POST-INSTALLATION AND PRE-COMMISSIONING CHECKS

When the equipment is operating, make sure that all connections are:

- properly secured/tightened to prevent any leakage during commissioning;
- connected correctly.







7 - COMMISSIONING/MAINTENANCE EQUIPMENT





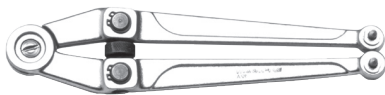



7.1 - LIST OF EQUIPMENT

Use of commissioning/maintenance equipment	
Operator qualification	<ul style="list-style-type: none"> • Mechanical maintenance technician; • Electrical maintenance technician; • Installer; • User's technician.
PPE required	<div style="display: flex; align-items: center;">  </div> <div style="background-color: #f4a460; padding: 5px; margin-top: 5px;"> <p>⚠ WARNING!</p> </div> <p>The PPE listed in this table is related to the risk associated with the equipment. For the PPE required to protect against risks associated with the workplace, installation or operating conditions, please refer to:</p> <ul style="list-style-type: none"> • the regulations in force in the country of installation; • any information provided by the Safety Manager at the installation facility.

Tab. 7.37

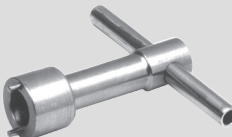
The types of equipment required to commission and service the equipment are described in “”:

Ref.	Equipment type	Image
A	Combination wrench	
B	Adjustable wrench	
C	Roller compass spanner	
D	Double ended bi-hex tubular socket wrench	
E	Bent male hex key	
F	Male T-handle hex wrench	

Ref.	Equipment type	Image
G	T-handle hex socket wrench	
H	Phillips screwdriver	
I	Slotted screwdriver	
L	O-ring extraction tool	
M	Circlip pliers	
N	Fiorentini special key	
O	Fiorentini special key	
P	Fiorentini special tool	
Q	Torx key	

Tab. 7.38

7.2 - EQUIPMENT NEEDED FOR THE DIFFERENT CONFIGURATIONS

Each table is distinguished by:

Term	Description
K./Wr.	Key, with reference to the equipment indicated in "".
Code	Code, referring to the equipment.
DN	Indicates the Nominal Diameter of the reference configuration.
L.	Length, referred to the equipment.
Ref.	Reference to the equipment.
Type	Type (size) or code of the equipment.

Tab. 7.39

DIVAL 600 | REGULATOR WITH IN LINE MONITOR FUNCTION

Equipment		Size [inches] DN [mm]		
Ref.	Type	1" 25	1" ½ 40	2" 50
A	K./Wr.	10 - 12 - 13 - 17 - 22 - 24		
D	K./Wr.	24 - 26 - 27 - 36 - 46		
E	K./Wr.	19		
F	K./Wr.	3 - 4 - 5 - 6 - 8		
G	K./Wr.	7 - 8 - 10		

Tab. 7.40

DIVAL 600 + LA

Equipment		Size [inches] DN [mm]		
Ref.	Type	1" 25	1" ½ 40	2" 50
A	K./Wr.	10 - 12 - 13 - 17 - 22 - 24		
D	K./Wr.	24 - 26 - 27 - 36 - 46		
E	K./Wr.	19		
F	K./Wr.	3 - 4 - 5 - 6 - 8		
G	K./Wr.	7 - 8 - 10		
Q	Type	T 20		

Tab. 7.41

8 - COMMISSIONING

8.1 - GENERAL WARNINGS

8.1.1 - SAFETY REQUIREMENTS FOR COMMISSIONING

HAZARD!

During commissioning the risks associated with any discharges to the atmosphere of flammable or noxious gases must be evaluated.

HAZARD!

In case of installation on distribution networks for natural gas, consider the risk associated with explosive mixtures (gas/air) being formed inside the piping, if the line is not subjected to inerting.

WARNING!

During commissioning, any unauthorised personnel must keep away.
The no entry area has to be marked with signs and/or boundaries.

NOTICE!

Commissioning has to be carried out by authorised and qualified personnel.

The equipment and accessories (regulator with in-line monitor function, LA incorporated slam-shut valve) are supplied already calibrated.



NOTICE!

It is possible that for various reasons (e.g. vibrations during transport) the calibration of the equipment's accessories may vary, although within the values indicated on the identification plates.

Before commissioning the equipment, it is necessary to check that:

- all shut-off valves (inlet, outlet, any bypass) are closed;
- the gas is at a temperature within the limits specified on the data plate.

Commissioning

Operator qualification	<ul style="list-style-type: none"> • Installer; • Qualified technician.
PPE required	<div style="text-align: center;">  </div> <div style="background-color: #f96; padding: 5px; margin-top: 5px;">  WARNING! </div> <p>The PPE listed in this table is related to the risk associated with the equipment. For the PPE required to protect against risks associated with the workplace, installation or operating conditions, please refer to:</p> <ul style="list-style-type: none"> • the regulations in force in the country of installation; • any information provided by the Safety Manager at the installation facility.
Equipment required	Please refer to the chapter "7 - Attrezzature per la messa in servizio/manutenzione".

Tab. 8.42

8.2 - PRELIMINARY PROCEDURES FOR COMMISSIONING

HAZARD!

Before commissioning the equipment, it must be ensured that any source of explosion has been eliminated if there is such a danger.

WARNING!

Before commissioning, you need to make sure that the characteristics of the equipment are suitable for the conditions of use.

ATTENTION!

To protect the equipment from damage, never:

- pressurise the equipment through a valve located downstream of it;
- depressurise the equipment through a valve located upstream of it.

Commissioning can be carried out using two different procedures:

Commissioning types

Injection of an inert fluid	Pressurising the equipment by injecting an inert fluid (e.g. nitrogen) to avoid potentially explosive mixtures for services with combustible gases. <div style="background-color: #f4a460; padding: 5px;"> WARNING!</div> During pressurisation, always check that the equipment has no leaks.
Direct injection	Direct injection of gas into pipes, keeping the gas velocity in the pipes as low as possible (maximum permitted value of 5 m/s).

Tab. 8.43

8.3 - PROPER COMMISSIONING CHECK

Completely sprinkle the equipment with a foaming solution (or equivalent control system) in order to check the tightness of the external surfaces of the regulator and the connections made during the installation.

8.4 - CALIBRATION OF EQUIPMENT AND ACCESSORIES INSTALLED

 **NOTICE!**

To properly calibrate the equipment and accessories present, refer to the accuracy class indicated on the nameplates (see section “2.8 - Nameplates applied”).

8.5 - REGULATOR COMMISSIONING PROCEDURE

In the application consisting of two pressure adjusting lines, it is advisable to commission one line at a time, starting with the line with the lowest set point.

The set point value is mentioned on the test certificate enclosed with each piece of equipment.

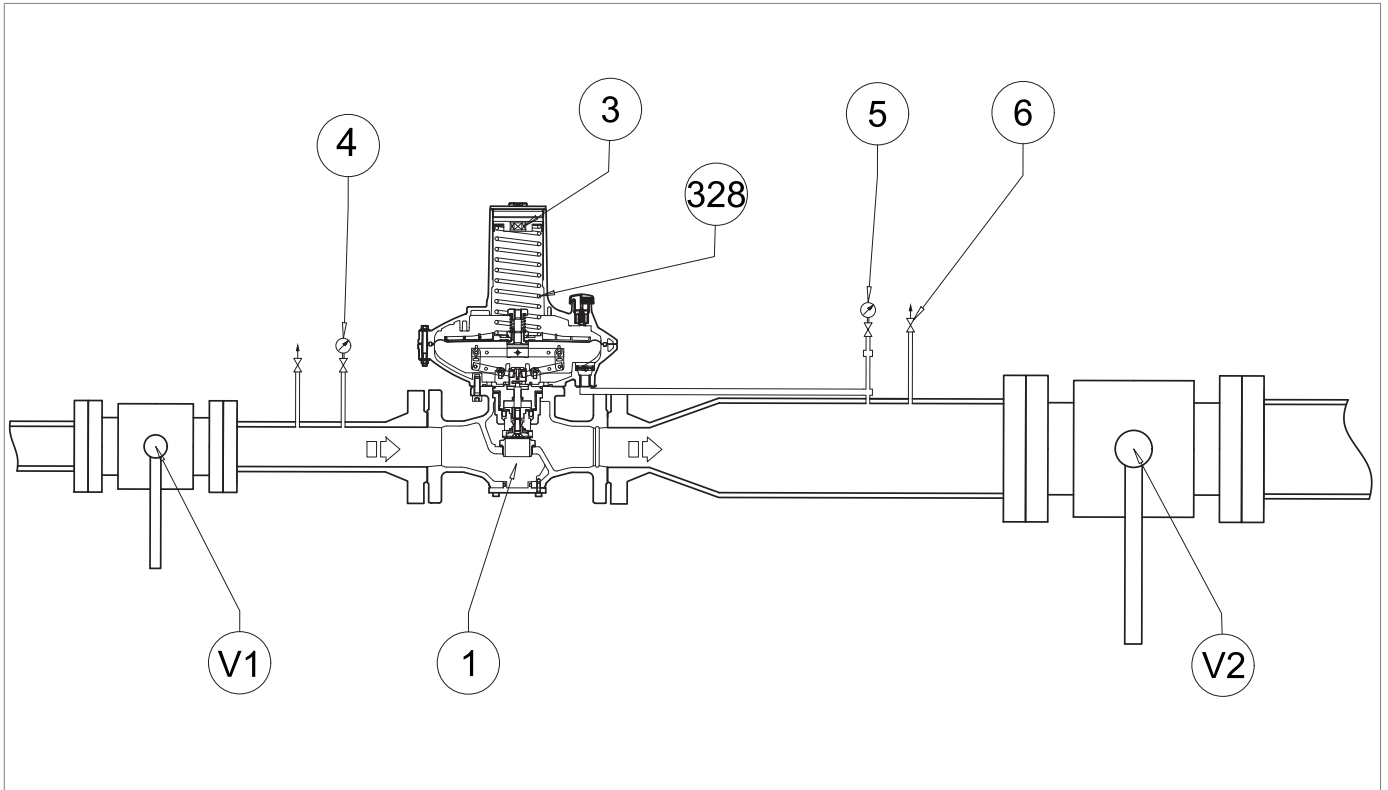

Fig. 8.16. Commissioning the DIVAL 600 regulator

Step	Action
1	Partially open the bleed cock (6).
2	<p>Partially open the upstream shut-off valve (V1), checking that the downstream pressure (Pd) indicated on the downstream pressure gauge (5) does not exceed the required calibration value by over 50%.</p> <p>! NOTICE!</p> <p>In the first line pressurisation phase, the downstream pressure (Pd) indicated on the downstream pressure gauge (5) could exceed that required calibration value, depending on the response time of the regulator.</p> <p>! NOTICE!</p> <p>With regulators with calibration pressure up to 80 mbar, the response time is longer than that of regulators with calibration pressure above 80 mbar.</p>
3	When the regulator is put into service, the downstream pressure (Pd) indicated on the downstream pressure gauge (5) will be equal to the calibration value of the regulator.
4	<p>a - FOR INITIAL COMMISSIONING OF THE REGULATION LINE</p> <p>If the pressure downstream (Pd) is not at the required calibration value, proceed as follows:</p> <ul style="list-style-type: none"> • downstream pressure value (Pd) lower than required calibration value: load the setting spring by turning the adjustment ring nut clockwise (3) • downstream pressure value (Pd) higher than required calibration value: load the setting spring by turning the adjustment ring nut anti-clockwise (3) <p>b - AFTER MAINTENANCE OF THE REGULATION LINE</p> <ul style="list-style-type: none"> • load the setting spring (328) and increase the pressure value of the main regulator (1) by turning the adjustment ring nut clockwise (3)
5	Check the downstream pressure (Pd) referring to the downstream pressure gauge (5).
6	Close the bleed cock (6).
7	<p>Check that the downstream pressure (Pd), after an increment phase, does not exceed the closing pressure value (refer to the SG value displayed on the plate, see par. "2.8 - Nameplates applied").</p> <p>! NOTICE!</p> <p>If the pressure in the pipe section between the regulator and the downstream shut-off valve (V2) exceeds the closing pressure value, consult chapter "10 - Troubleshooting" to clear the causes of the malfunctions.</p>
8	<p>Check the tightness of all the fittings between the shut-off valves (V1, V2).</p> <p>! NOTICE!</p> <p>Check for leaks with a foaming agent.</p>
9	In case of external leaks, eliminate the leak points and repeat the procedure from step 7.
10	<p>Open downstream shut-off valve (V2) very slowly until the pipeline fills completely.</p> <p>! NOTICE!</p> <p>If the pressure of the downstream pipeline is lower than the calibration pressure, partially open the downstream shut-off valve (V2) so as to not to exceed the maximum flow rate value of the installation.</p>

Tab. 8.44

8.6 - COMMISSIONING PROCEDURE OF REGULATION LINE: DIVAL 600 REGULATOR + DIVAL 600 REGULATOR WITH IN LINE MONITOR FUNCTION

NOTICE!

VALID FOR REGULATORS WITH DOWNSTREAM PRESSURE UP TO 80mbar

The setting spring (328.1) of the main regulator (1) must allow you to obtain the downstream pressure value (Pd) 10-20% higher than the calibration pressure value of the regulator with in-line monitor function (2).

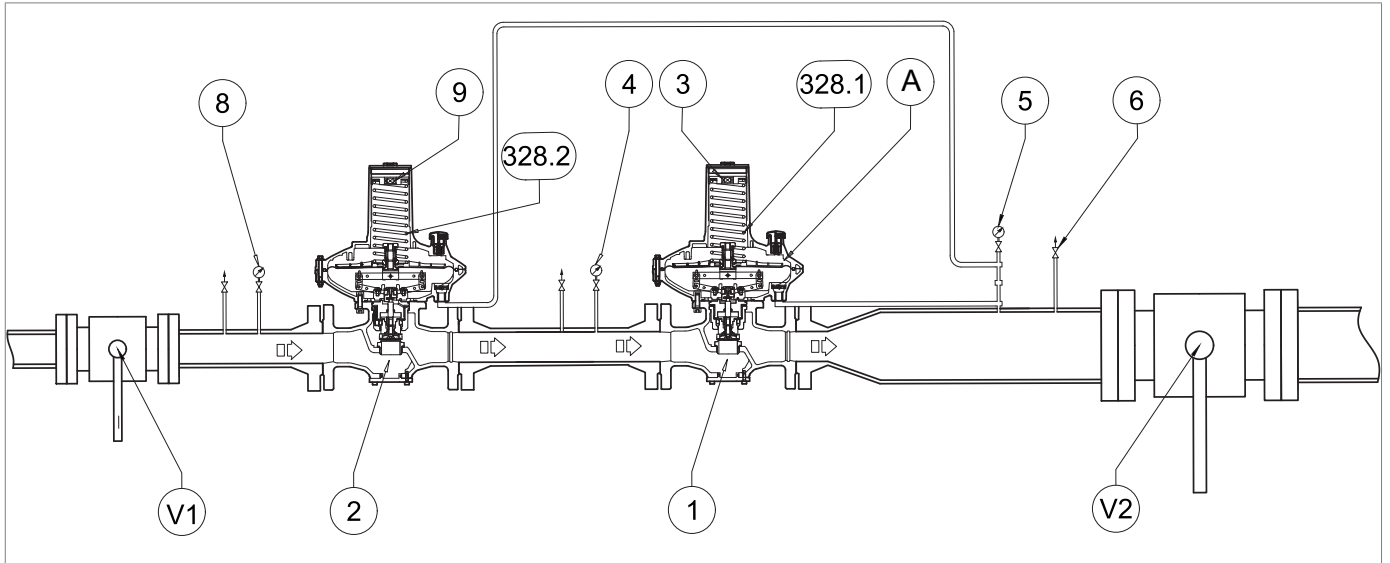
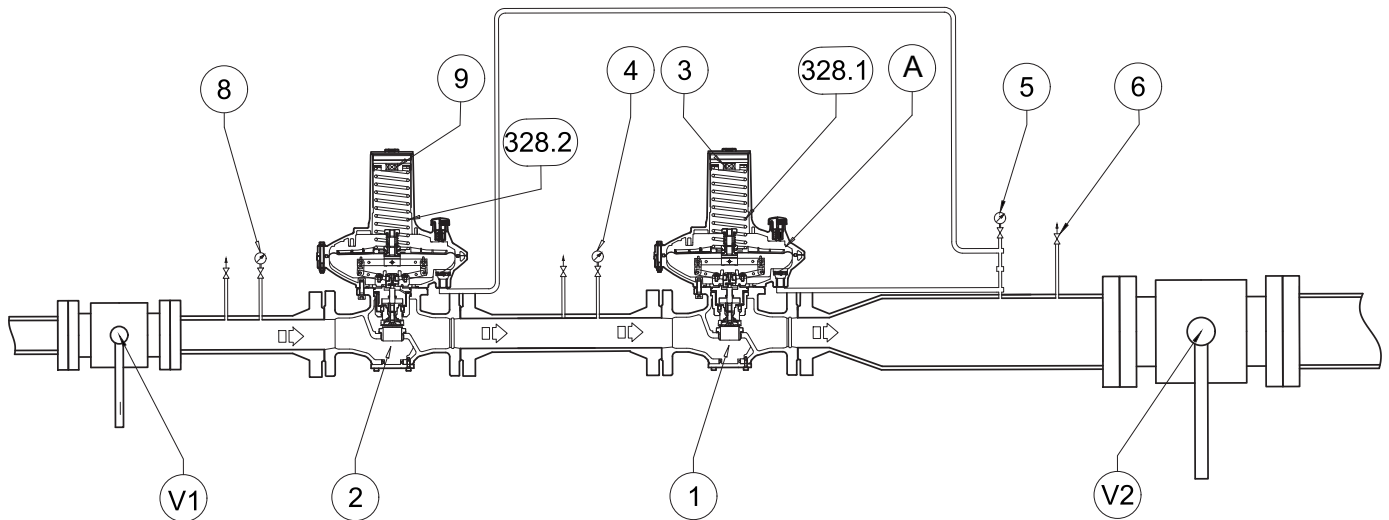

Fig. 8.17. Commissioning of DIVAL 600 regulator + regulator with in-line monitor function

Step	Action
1	Partially open the bleed cock (6).
2	<p>Partially open the upstream shut-off valve (V1), checking that the downstream pressure (Pd) indicated on the downstream pressure gauge (5) does not exceed the required calibration value by over 50%.</p> <p>! NOTICE!</p> <p>In the first line pressurisation phase, the downstream pressure (Pd) indicated on the downstream pressure gauge (5) could exceed that required calibration value, depending on the response time of the main regulator (1).</p> <p>! NOTICE!</p> <p>With regulators with calibration pressure up to 80 mbar, the response time is longer than that of regulators with calibration pressure above 80 mbar.</p>
3	When the main regulator (1) is put into service, the downstream pressure (Pd) indicated on the downstream pressure gauge (5) will be equal to the calibration value of the main regulator (1).
4	<p>Check that the regulator with in-line monitor function (2) is fully open (100%).</p> <p>! NOTICE!</p> <p>The regulator with monitor function (2) is fully open, when the pressure indicated on the intermediate pressure gauge (4) is the same as the upstream pressure gauge (8).</p>
5	Open the upstream shut-off valve (V1) completely.
6	<p>Increase the downstream pressure value (Pd) beyond the calibration pressure of the regulator with monitor function (2), by turning the adjustment ring nut (3) of the main regulator (1) clockwise.</p> <p>! NOTICE!</p> <p>If the setting spring of the main regulator (1) does not reach a sufficient pressure to trip the regulator with in-line monitor function (2), pressurise the chamber (A) by using an external source (see par. "8.6.1 - Pressurising with external source").</p> <p>! NOTICE!</p> <p>The value of the pressure introduced by the external source can be up to 50% more than the calibration value of the regulator with in-line monitor function (2).</p>
7	Check that the regulator with in-line monitor function (2) is running, checking that the pressure indicated on the intermediate pressure gauge (4) is comparable to the calibration value of the regulator with in-line monitor function (2).
8	<p>a - FOR INITIAL COMMISSIONING OF THE REGULATION LINE</p> <p>If the downstream pressure (Pd) is not at the required calibration value for the regulator with in-line monitor function (2), proceed as follows:</p> <ul style="list-style-type: none"> downstream pressure value (Pd) lower than required calibration value: load the setting spring by turning the adjustment ring nut clockwise (9) downstream pressure value (Pd) higher than required calibration value: load the setting spring by turning the adjustment ring nut anti-clockwise (9) <p>b - AFTER MAINTENANCE OF THE REGULATION LINE</p> <ul style="list-style-type: none"> load the setting spring (328.2) and increase the pressure value of the regulator with monitor function (2) by turning the adjustment ring nut clockwise (9)
9	<p>Check the calibration value of the regulator with in-line monitor function (2), referring to the downstream pressure gauge (5).</p> <p>! NOTICE!</p> <p>If the calibration pressure is not as pre-established, repeat steps 8a (first commissioning) or 8b (after maintenance).</p>



Commissioning of DIVAL 600 regulator + regulator with in-line monitor function

Step	Action
10	Slowly close the bleed cock (6).
11	<p>Check that the downstream pressure, after an increment phase, does not exceed the closing pressure value of the regulator with in-line monitor function (2) (refer to the SG value displayed on the plate, see par. "2.8 - Nameplates applied").</p> <div style="border: 1px solid black; padding: 5px;"> <p>! NOTICE!</p> <ul style="list-style-type: none"> • If the downstream pressure exceeds the closing pressure value, refer to chapter "10 - Troubleshooting" to clear the causes of the malfunctions. • Check the pressure referring to the downstream pressure gauge (5). </div>
12	Partially open the bleed cock (6).
13	Discharge the regulation spring of the main regulator (1) or disconnect the external pressure source from the chamber (A).
14	<p>Check that the regulator with in-line monitor function (2) is fully open (100%).</p> <div style="border: 1px solid black; padding: 5px;"> <p>! NOTICE!</p> <p>The regulator with in-line monitor function (2) is fully open, when the pressure indicated on the intermediate pressure gauge (4) is the same as the upstream pressure gauge (8).</p> </div>
15	Check that the calibration pressure of the main regulator (1) is as pre-established by referring to the pressure value indicated on the downstream pressure gauge (5).
16	<p>a - FOR INITIAL COMMISSIONING OF THE REGULATION LINE</p> <p>If the pressure downstream (Pd) is not at the required calibration value, proceed as follows:</p> <ul style="list-style-type: none"> • downstream pressure value (Pd) lower than required calibration value: load the setting spring by turning the adjustment ring nut clockwise (3) • downstream pressure value (Pd) higher than required calibration value: load the setting spring by turning the adjustment ring nut anti-clockwise (3) <p>b - AFTER MAINTENANCE OF THE REGULATION LINE</p> <ul style="list-style-type: none"> • load the setting spring (328.1) and increase the pressure value of the main regulator (1) by turning the adjustment ring nut clockwise (3)
17	Slowly close the bleed cock (6).

Step	Action
18	<p>Check that the downstream pressure, after an increment phase, does not exceed the closing pressure value of the main regulator (1) (refer to the SG value displayed on the plate, see par. "2.8 - Nameplates applied").</p> <div style="border: 1px solid black; padding: 5px;"> <p>! NOTICE!</p> <ul style="list-style-type: none"> • If the downstream pressure exceeds the closing pressure value, refer to chapter "10 - Troubleshooting" to clear the causes of the malfunctions. • Check the pressure referring to the downstream pressure gauge (5). </div>
19	Using a foaming agent, check all the joints between shut-off valves (V1, V2) for proper sealing.
20	In case of external leaks, eliminate the leak points and repeat the procedure from step 1.
21	<p>Slowly open the downstream shut-off valve V2 until the piping has been completely filled.</p> <div style="border: 1px solid black; padding: 5px;"> <p>! NOTICE!</p> <ul style="list-style-type: none"> • If the pressure of the downstream pipeline is lower than the calibration pressure, partially open the downstream shut-off valve (V2) so as to not to exceed the maximum flow rate value of the installation. • Check the pressure referring to the downstream pressure gauge (5). </div>

Tab. 8.45

8.6.1 - PRESSURISING WITH EXTERNAL SOURCE

If the setting spring of the main regulator (1) does not reach a sufficient pressure to put into service the regulator with in-line monitor function (2), you may pressurise the chamber (A) of the control head of the main regulator (1) by using an external source.

Pressurisation can be done:

- with external lines;
- manually.

The introduced pressure is controlled by using pressure gauges or transducers.

To correctly discharge the introduced pressure, make sure there is an additional bleed cock (18).

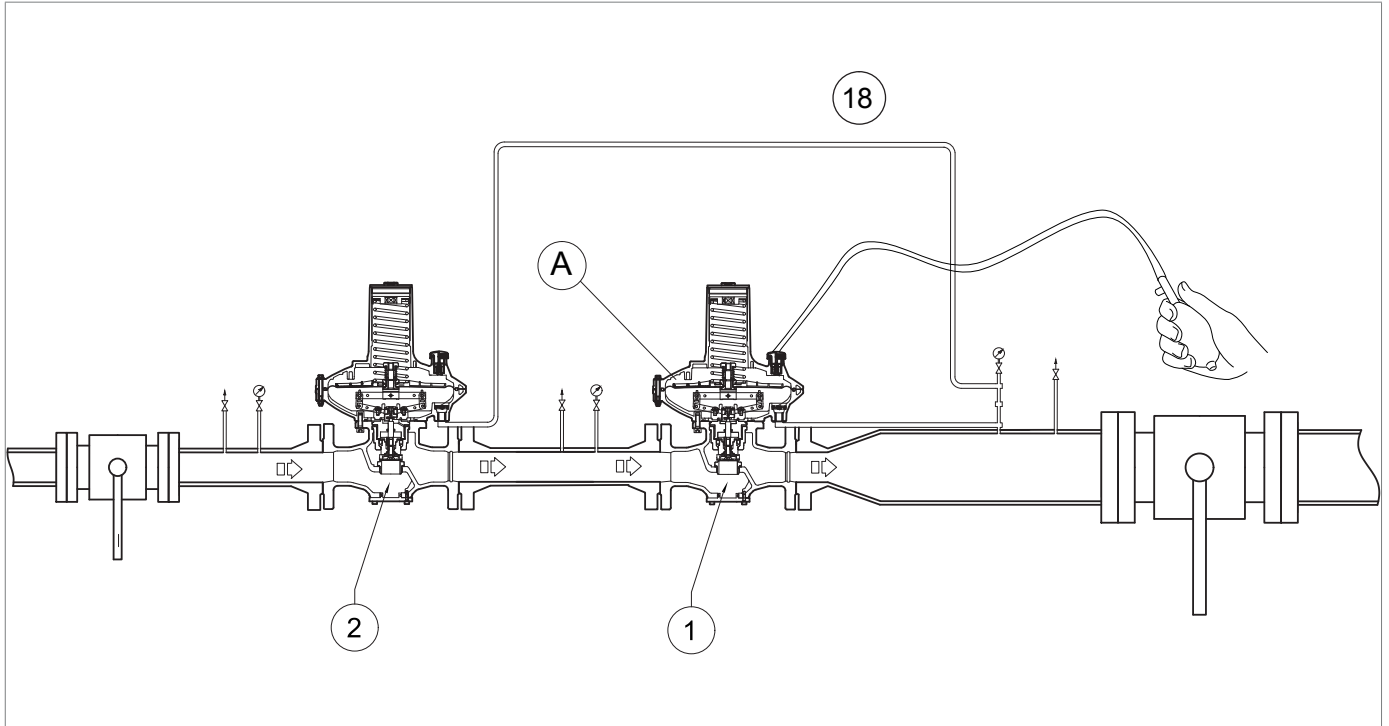

Fig. 8.18. Pressurising with external source (hand pump)

8.7 - COMMISSIONING PROCEDURE OF DIVAL 600 REGULATOR WITH LA SLAM-SHUT VALVE

8.7.1 - INTERNAL TIGHTNESS CHECK OF LA SLAM-SHUT VALVE

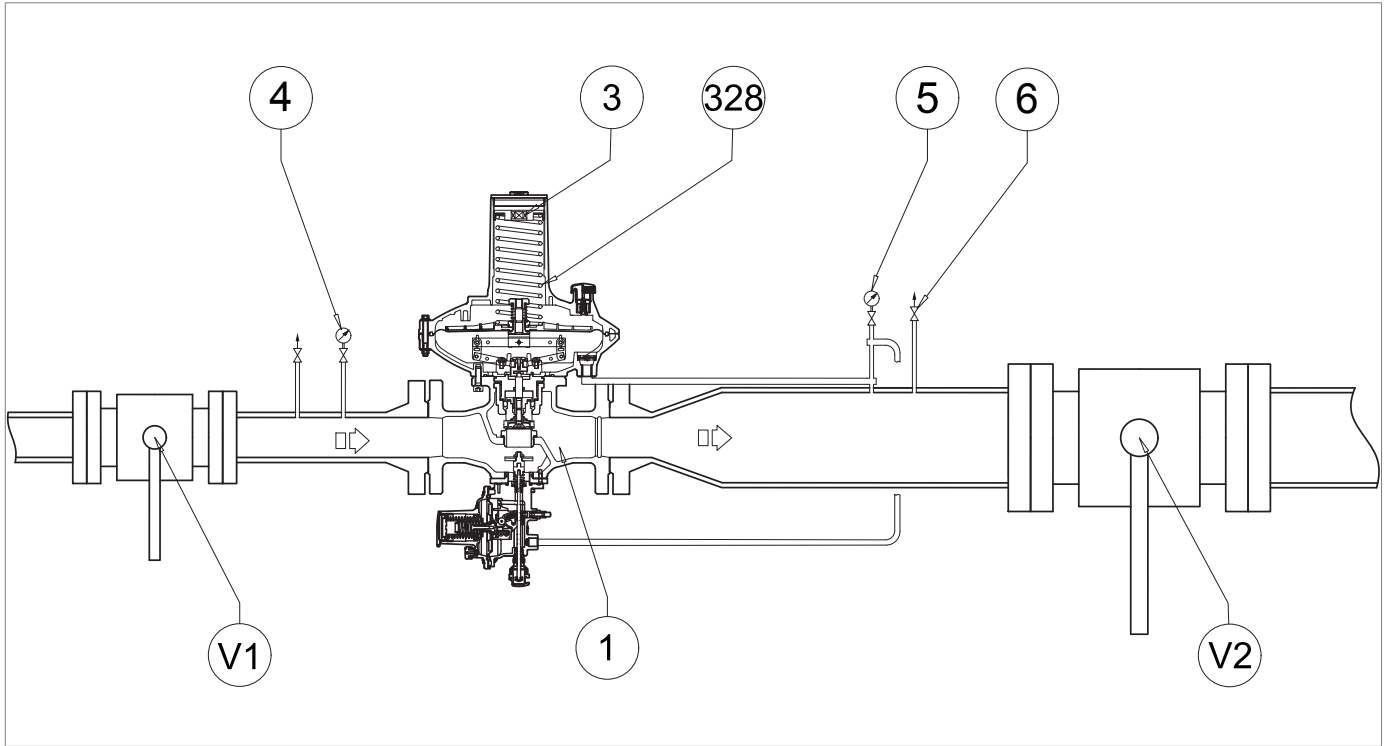

Fig. 8.19. Commissioning of the DIVAL 600 regulator with LA slam-shut valve

Step	Action
1	Check that the slam-shut valve is in the shut-off position.
2	Open the bleed cock (6) to fully discharge the downstream section.
3	Slowly open the upstream shut-off valve (V1).
4	Check the internal tightness of the slam-shut valve by means of the bleed cock (6). <div style="border: 1px solid blue; padding: 5px; margin-top: 10px;"> <p>! NOTICE!</p> <ul style="list-style-type: none"> • Check the seal with a foaming substance; • In case of leaks, please refer to the chapter “10 - Troubleshooting” to clear the causes of malfunctions. </div>

Tab. 8.46

8.7.2 - COMMISSIONING OF THE DIVAL 600 REGULATOR WITH LA SLAM-SHUT VALVE

For the following procedure, please refer to Figure 8.19 in par. "8.7.1 - Internal tightness check of LA slam-shut valve":

Step	Action
1	Make sure that the bleed cock (6) is partially open.
2	<p>Check that the LA slam-shut valve is in the shut-off position.</p> <p>! NOTICE! If the LA slam-shut valve is in the open position, close it using the manual button (fig. 8.20, ref. 10).</p>
3	Partially open the upstream shut-off valve (V1), checking the pressure indicated by the upstream pressure gauge (4).
4	<p>Perform the internal tightness check of the LA slam-shut valve, referring to chapter "8.7.1 - Internal tightness check of LA slam-shut valve".</p> <p>! NOTICE! In case of leaks, please refer to the chapter "10 - Troubleshooting" to clear the causes of malfunctions.</p>
5	Slowly pressurise the control line by turning the knob on the LA slam-shut valve (refer to "Operation" in par. 4.6.3.1), checking that the downstream pressure (Pd) indicated on the downstream pressure gauge (5) does not exceed the required calibration value by over 50%.
6	<p>When the regulator is put into service, the pressure on the downstream pressure gauge (5) will be equal to the calibration value of the main regulator.</p> <p>! NOTICE! In the first line pressurisation phase, the pressure on the downstream pressure gauge (5) could exceed the required calibration value, depending on the response time of the regulator.</p>
7	Open the upstream shut-off valve (V1) completely.
8	Check calibrations of the pressure switch of the LA slam-shut valve by referring to paragraph "8.7.3 - Procedure for calibrating the pressure switch FOR THE LA incorporated SLAM-SHUT VALVE".
9	<p>a - FOR INITIAL COMMISSIONING OF THE REGULATION LINE If the pressure downstream (Pd) is not at the required calibration value, proceed as follows:</p> <ul style="list-style-type: none"> • downstream pressure value (Pd) lower than required calibration value: load the setting spring by turning the adjustment ring nut clockwise (3) • downstream pressure value (Pd) higher than required calibration value: load the setting spring by turning the adjustment ring nut anti-clockwise (3) <p>b - AFTER MAINTENANCE OF THE REGULATION LINE</p> <ul style="list-style-type: none"> • load the setting spring (328) and increase the pressure value of the regulator (1) by turning the adjustment ring nut clockwise (3)
10	Check the downstream pressure (Pd) referring to the downstream pressure gauge (5).
11	Close the bleed cock (6).
12	<p>Check that the downstream pressure (Pd), after an increment phase, does not exceed the closing pressure value (refer to the SG value displayed on the plate, see par. "2.8 - Nameplates applied").</p> <p>! NOTICE! If the pressure in the pipe section between the regulator and the downstream shut-off valve (V2) exceeds the closing pressure value, consult chapter "10 - Troubleshooting" to clear the causes of the malfunctions.</p>

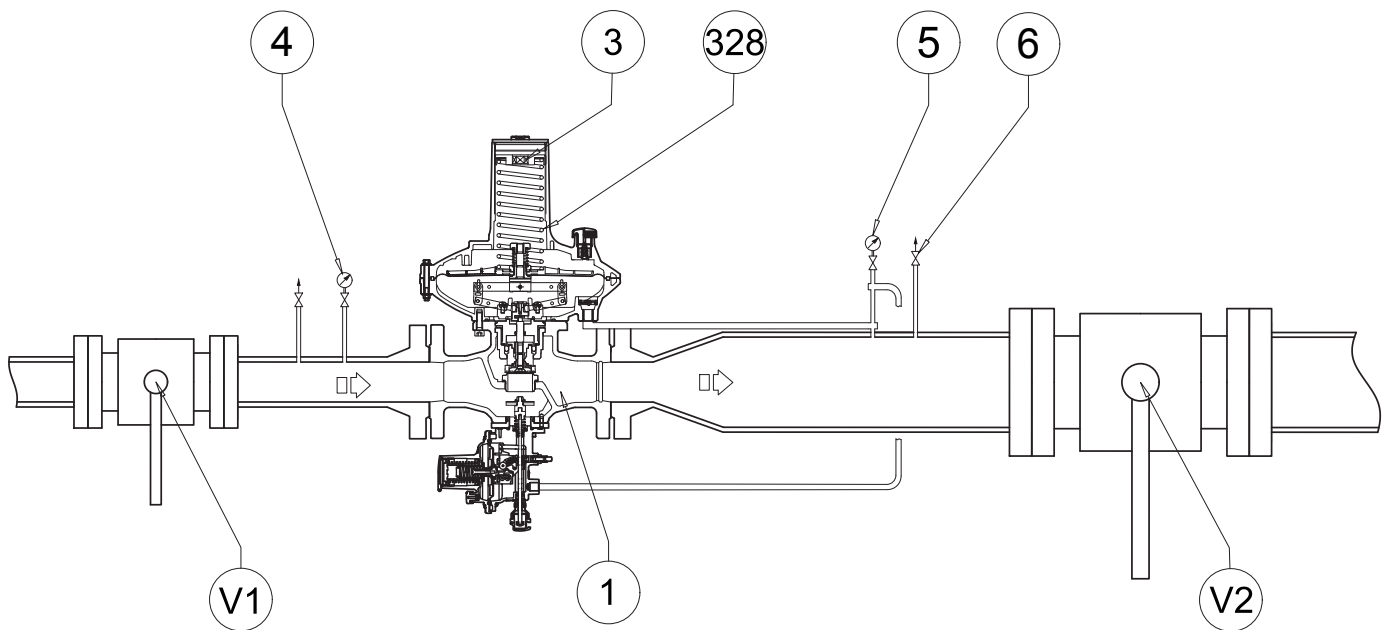

Commissioning of the DIVAL 600 regulator with LA slam-shut valve

Step	Action
13	<p>Check the tightness of all the fittings between the shut-off valves (V1, V2).</p> <p>NOTICE! Check for leaks with a foaming agent.</p>
14	<p>If external leaks are noticed, eliminate the leak points and repeat the procedure from step 7.</p>
15	<p>Open downstream shut-off valve (V2) very slowly until the pipeline fills completely.</p> <p>NOTICE! If the pressure of the downstream pipeline is lower than the calibration pressure, partially open the downstream shut-off valve (V2) so as to not to exceed the maximum flow rate value of the installation.</p>

Tab. 8.47

8.7.3 - PROCEDURE FOR CALIBRATING THE PRESSURE SWITCH FOR THE LA INCORPORATED SLAM-SHUT VALVE

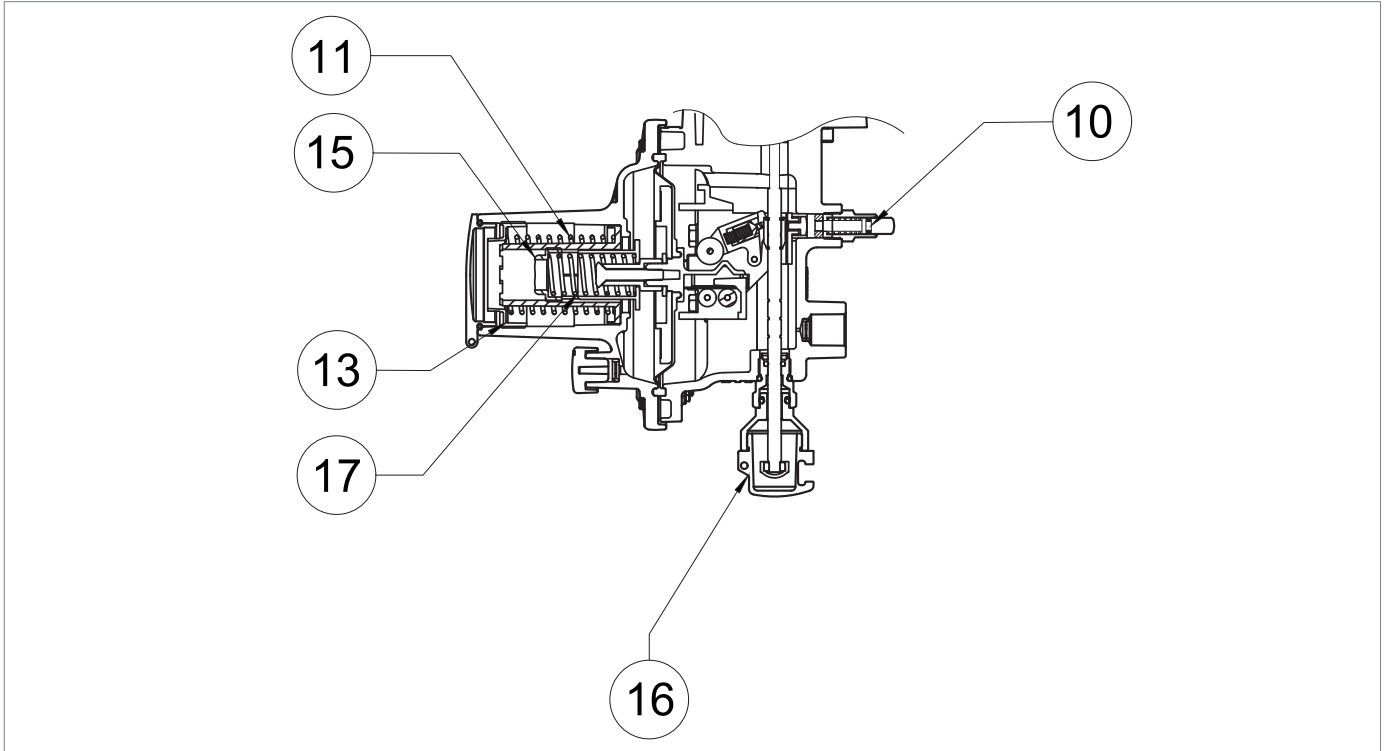

Fig. 8.20. Calibration of pressure switch for LA slam-shut valve

SPRING CALIBRATION FOR MAXIMUM PRESSURE TRIP

Step	Action
1	<p>Increase the downstream pressure to the tripping value of the slam-shut valve, connecting an external pressure source to the bleed cock (fig. 8.16, ref. 6) placed on the downstream pipe, making sure to open an additional bleed cock (fig. 8.21, ref. 18).</p> <div style="border: 1px solid black; padding: 5px;"> <p>! NOTICE!</p> <p>Check the pressure referring to the downstream pressure gauge (fig. 8.16, ref. 5).</p> <p>If the slam-shut valve:</p> <ul style="list-style-type: none"> • trips before the expected pressure value: screw in (clockwise) the adjustment ring nut (13) so as to further compress the spring (11); • does not trip at the expected pressure value: unscrew (anti-clockwise) the adjustment ring nut (13) so as to relieve the spring (11). </div>
2	Decrease the pressure of the downstream section by opening the additional bleed cock (21, ref. 18) to bring it up to the calibration value of the main regulator.
3	Close the additional bleed cock (fig. 8.21, ref. 18).
4	Resetting the slam-shut valve by turning the reset knob (16).
5	Repeat steps 1-2-3-4 at least three times, observing the operating limits indicated on the nameplate.
6	Disconnect the external pressure source from the bleed cock (fig. 8.16, ref. 6).

Tab. 8.48

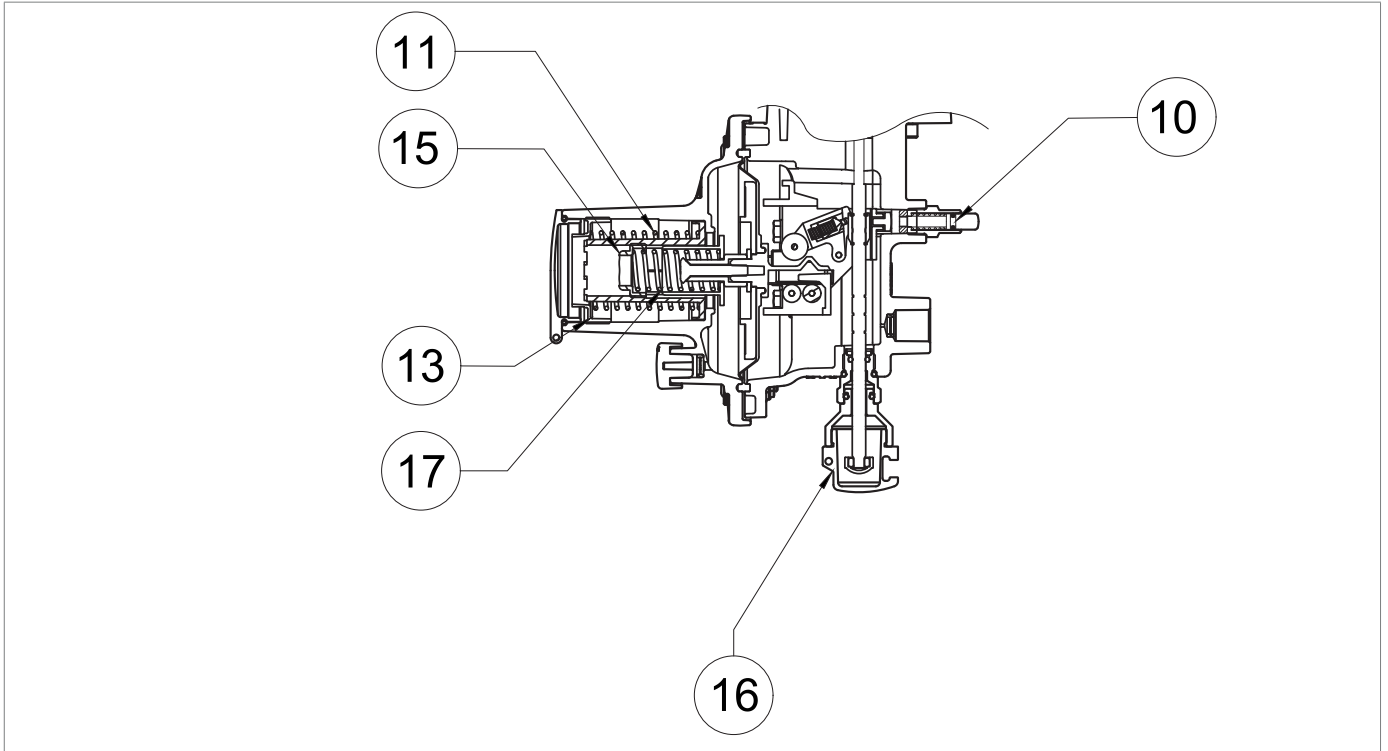

Fig. 8.20. Calibration of pressure switch for LA slam-shut valve

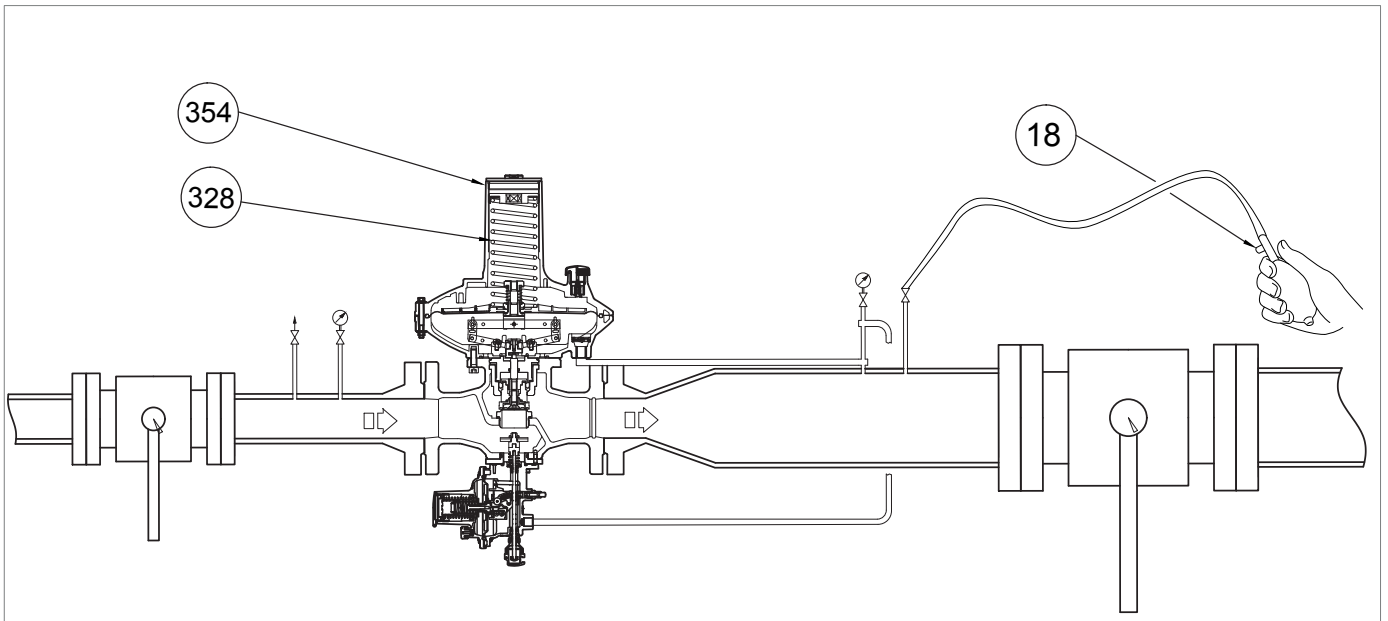

Fig. 8.21. Pressurising with external source for incorporated LA slam-shut valve

SPRING CALIBRATION FOR MINIMUM PRESSURE TRIP (IF PRESENT)

Step	Action
1	Partially open the bleed cock (fig. 8.16, ref. 6) to the atmosphere and keep it open for the next steps.
2	Turn the adjustment ring nut (fig. 8.16, ref. 3) of the regulator anti-clockwise to decrease the downstream pressure (Pd) to the minimum pressure required for tripping of the slam-shut valve.
3	<p>If necessary, remove the closing cap (fig. 8.21, ref. 354) together with the adjustment ring nut and remove the regulation spring (fig. 8.21, ref. 328).</p> <div style="border: 1px solid black; padding: 5px;"> <p>! NOTICE!</p> <p>Check the tripping pressure value of the slam-shut valve indicated on the downstream pressure gauge (fig. 8.19, ref. 5).</p> </div>
4	<p>If the slam-shut valve:</p> <ul style="list-style-type: none"> trips before the expected pressure value, unscrew (anticlockwise) the adjustment ring nut (fig. 8.20, ref. 15), to relieve the spring (fig. 8.20, ref. 17); does not trip at the expected pressure value, screw in (clockwise) the adjustment ring nut (fig. 8.20, ref. 15) to further compress the spring (fig. 8.20, ref. 17).
5	<p>After having checked that the slam-shut valve trips at the preset value, proceed as follows:</p> <ol style="list-style-type: none"> Close the air vent valve (fig. 8.16, ref. 6) Position the regulation spring (fig. 8.21, ref. 328), the closing cap (fig. 8.21, ref. 354), and adjustment ring nut (fig. 8.16, ref. 3) Slowly open the upstream shut-off valve (V1) until the downstream pressure value (Pd) reaches the calibration value of the regulator, referring to the downstream pressure gauge (fig. 8.16, ref. 5) Close the upstream shut-off valve (V1) Slowly and partially open the air vent valve (fig. 8.16, ref. 6) to decrease the downstream pressure referring to the downstream pressure gauge (fig. 8.16, ref. 5) until it reaches the minimum pressure tripping value Check the minimum pressure spring for proper calibration by repeating steps 2-3-4 at least three times Calibrate the main regulator referring to par. "8.5 - Regulator commissioning procedure"
6	Open the slam-shut valve by acting on the reset knob (fig. 8.20, ref. 16) and keep it open manually.
7	Turn the adjustment ring nut clockwise (fig. 8.16, ref. 3) to increase the downstream pressure to the regulator's setpoint.
8	Set the slam-shut valve by acting on the reset knob (fig. 8.20, ref. 16).
9	Close the bleed cock (fig. 8.16, ref. 6).

Tab. 8.49

COMMISSIONING THE REGULATOR

! NOTICE!

Please refer to "8.5 - Regulator commissioning procedure" of this chapter.

8.8 - COMMISSIONING PROCEDURE OF REGULATION LINE: DIVAL 600 REGULATOR + DIVAL 600 REGULATOR WITH IN LINE MONITOR + LA SLAM-SHUT VALVE FUNCTION

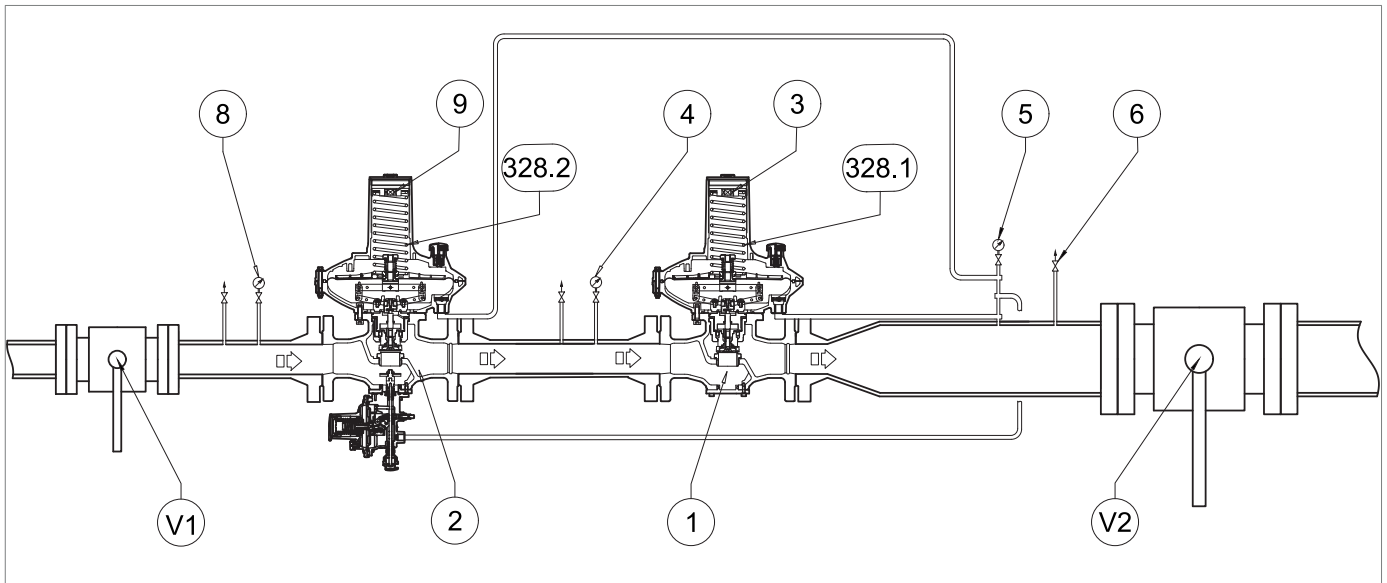





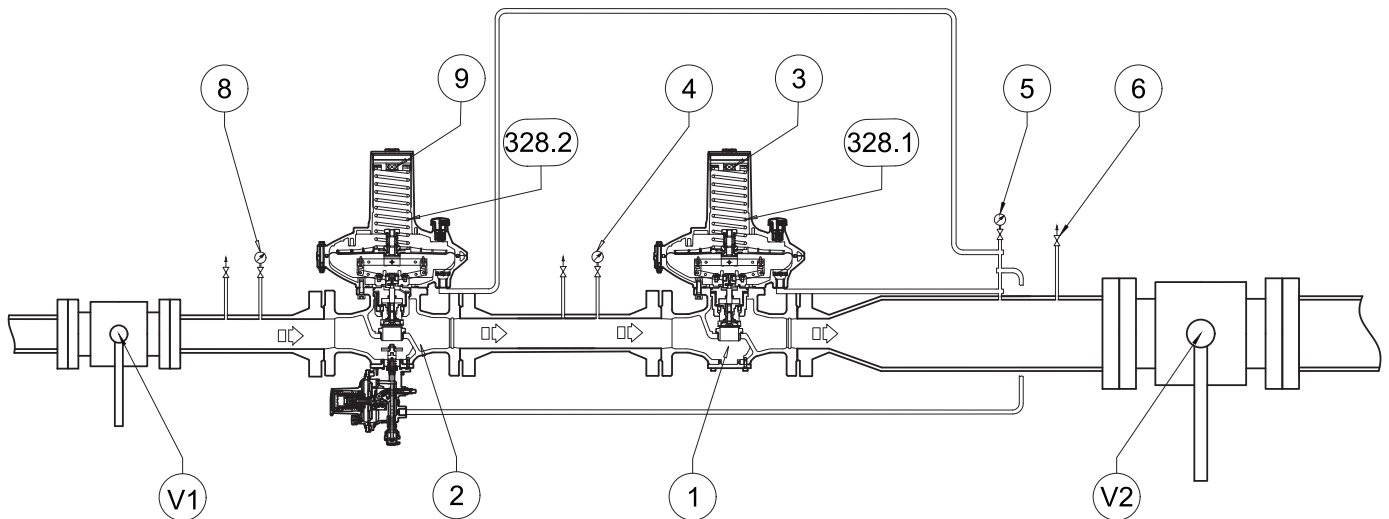

Fig. 8.22. Commissioning of DIVAL 600 regulator + regulator-monitor + LA

Step	Action
1	Make sure that the bleed cock (6) is partially open.
2	Check that the LA slam-shut valve is in the shut-off position. NOTICE! If the LA slam-shut valve is in the open position, close it using the manual button (fig. 8.20, ref. 10).
3	Slowly open the upstream shut-off valve (V1), checking the pressure indicated by the upstream pressure gauge (4).
4	Perform the internal tightness check of the LA slam-shut valve, referring to chapter "8.7.1 - Internal tightness check of LA slam-shut valve". NOTICE! In case of leaks, please refer to the chapter "10 - Troubleshooting" to clear the causes of malfunctions.
5	Make sure that the bleed cock (6) is partially open.
6	Slowly pressurise the regulation line, acting on the lever of the LA slam-shut valve (refer to section "Operation" in par. 4.6.3.1), checking that the downstream pressure (Pd) indicated on the downstream pressure gauge (5) does not exceed the required calibration value by over 50%.
7	When the regulator is put into service, the pressure on the downstream pressure gauge (5) will be equal to the calibration value of the main regulator. NOTICE! In the first line pressurisation phase, the pressure on the downstream pressure gauge (5) could exceed the required calibration value, depending on the response time of the regulator.
8	Check calibrations of the pressure switch of the LA slam-shut valve by referring to paragraph "8.7.3 - Procedure for calibrating the pressure switch FOR THE LA incorporated SLAM-SHUT VALVE".

Step	Action
9	 NOTICE! With regulators with calibration pressure up to 80 mbar, the response time is longer than that of regulators with calibration pressure above 80 mbar.
10	When the main regulator (1) is put into service, the downstream pressure (Pd) indicated on the downstream pressure gauge (5) will be equal to the calibration value of the regulator (1).
11	Check that the regulator with in-line monitor function (2) is fully open (100%).  NOTICE! The regulator with monitor function (2) is fully open, when the pressure indicated on the intermediate pressure gauge (4) is the same as the upstream pressure gauge (8).
12	Open the upstream shut-off valve (V1) completely.
13	Increase the downstream pressure value (Pd) beyond the calibration pressure of the regulator with monitor function (2), by turning the adjustment ring nut (3) of the main regulator (1) clockwise.  NOTICE! If the setting spring of the main regulator (1) does not reach a sufficient pressure to trip the regulator with in-line monitor function (2), pressurise the chamber (A) by using an external source (see par. "8.6.1 - Pressurising with external source").  NOTICE! The value of the pressure introduced by the external source can be up to 50% more than the calibration value of the regulator with in-line monitor function (2).
14	Check that the regulator with in-line monitor function (2) is running, checking that the pressure indicated on the intermediate pressure gauge (4) is equal to the calibration value of the regulator with in-line monitor function (2).
15	a - FOR INITIAL COMMISSIONING OF THE REGULATION LINE If the downstream pressure (Pd) is not at the required calibration value for the regulator with in-line monitor function (2), proceed as follows: <ul style="list-style-type: none"> • downstream pressure value (Pd) lower than required calibration value: load the setting spring by turning the adjustment ring nut clockwise (9) • downstream pressure value (Pd) higher than required calibration value: load the setting spring by turning the adjustment ring nut anti-clockwise (9) b - AFTER MAINTENANCE OF THE REGULATION LINE <ul style="list-style-type: none"> • load the setting spring (328.2) and increase the pressure value of the regulator with in-line monitor function (2) by turning the adjustment ring nut clockwise (9)
16	Check the calibration value of the regulator with in-line monitor function (2), referring to the downstream pressure gauge (5).  NOTICE! If the calibration pressure is not as pre-established, repeat steps 15a (first commissioning) or 15b (after maintenance).
17	Slowly close the bleed cock (6).



Commissioning of DIVAL 600 regulator + regulator-monitor + LA

Step	Action
18	<p>Check that the downstream pressure, after an increment phase, does not exceed the closing pressure value of the regulator with in-line monitor function (2) (refer to the SG value displayed on the plate, see par. "2.8 - Nameplates applied").</p> <div style="border: 1px solid blue; padding: 5px;"> <p>! NOTICE!</p> <ul style="list-style-type: none"> • If the downstream pressure exceeds the closing pressure value, refer to chapter "10 - Troubleshooting" to clear the causes of the malfunctions. • Check the pressure referring to the downstream pressure gauge (5). </div>
19	Partially open the bleed cock (6).
20	Discharge the regulation spring (328.1) of the main regulator (1) or disconnect the external pressure source from the chamber (A) (see par. "8.6.1 - Pressurising with external source").
21	<p>Check that the regulator with in-line monitor function (2) is fully open (100%).</p> <div style="border: 1px solid blue; padding: 5px;"> <p>! NOTICE!</p> <p>The regulator with monitor function (2) is fully open, when the pressure indicated on the intermediate pressure gauge (4) is the same as the upstream pressure gauge (8).</p> </div>
22	Check that the calibration pressure of the main regulator (1) is as pre-established by referring to the pressure value indicated on the downstream pressure gauge (5).
23	<p>a - FOR INITIAL COMMISSIONING OF THE REGULATION LINE</p> <p>If the pressure downstream (Pd) is not at the required calibration value, proceed as follows:</p> <ul style="list-style-type: none"> • downstream pressure value (Pd) lower than required calibration value: load the setting spring by turning the adjustment ring nut clockwise (3) • downstream pressure value (Pd) higher than required calibration value: load the setting spring by turning the adjustment ring nut anti-clockwise (3) <p>b - AFTER MAINTENANCE OF THE REGULATION LINE</p> <ul style="list-style-type: none"> • load the setting spring (328.1) and increase the pressure value of the main regulator (1) by turning the adjustment ring nut clockwise (3)
24	Slowly close the bleed cock (6).

Step	Action
25	<p>Check that the downstream pressure, after an increment phase, does not exceed the closing pressure value of the main regulator (1) (refer to the SG value displayed on the plate, see par. "2.8 - Nameplates applied").</p> <div style="border: 1px solid black; padding: 5px;"> <p>! NOTICE!</p> <ul style="list-style-type: none"> • If the downstream pressure exceeds the closing pressure value, refer to chapter "10 - Troubleshooting" to clear the causes of the malfunctions. • Check the pressure referring to the downstream pressure gauge (5). </div>
26	Using a foaming agent, check all the joints between shut-off valves (V1, V2) for proper sealing.
27	If external leaks are noticed, eliminate the leak points and repeat the procedure from step 10.
28	<p>Slowly open the downstream shut-off valve V2 until the piping has been completely filled.</p> <div style="border: 1px solid black; padding: 5px;"> <p>! NOTICE!</p> <ul style="list-style-type: none"> • If the pressure of the downstream pipeline is lower than the calibration pressure, partially open the downstream shut-off valve (V2) so as to not to exceed the maximum flow rate value of the installation. • Check the pressure referring to the downstream pressure gauge (5). </div>

Tab. 8.50

COMMISSIONING OF LA SLAM-SHUT VALVE

! NOTICE!

Refer to paragraph "8.7.3 - Procedure for calibrating the pressure switch FOR THE LA incorporated SLAM-SHUT VALVE".

8.9 - DEVICE CALIBRATION

8.9.1 - PRESSURE SWITCH CALIBRATION FOR THE LA SLAM-SHUT VALVE

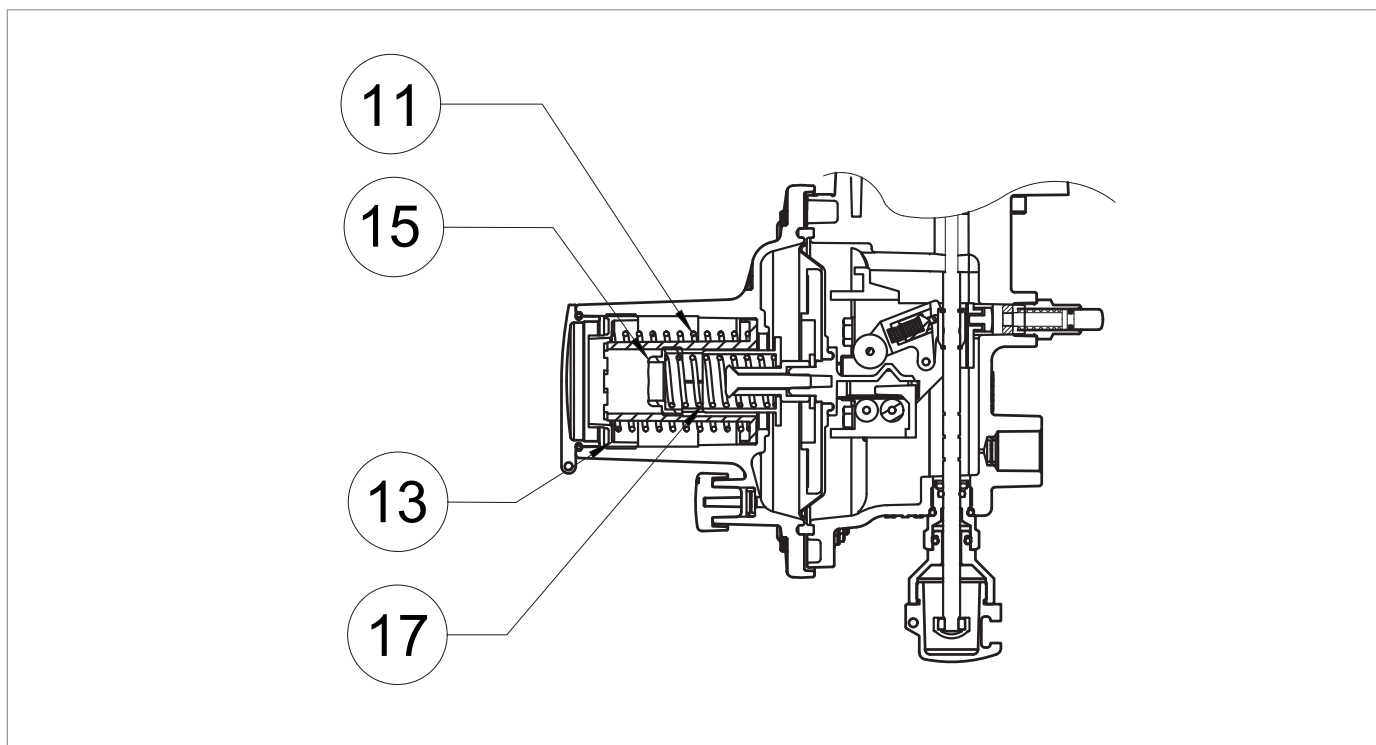

Fig. 8.23. Pressure switch calibration for the LA slam-shut valve

Turn the ring nut (13) for maximum tripping (11):

- anti-clockwise to decrease the slam-shut device tripping pressure;
- clockwise to increase the slam-shut device tripping pressure.

Turn the ring nut (15) for minimum tripping (17):

- anti-clockwise to decrease the slam-shut device tripping pressure;
- clockwise to increase the slam-shut device tripping pressure.

! NOTICE!

For calibration ranges, please refer to chapter “13 - Calibration tables”.

9 - MAINTENANCE AND FUNCTIONAL CHECKS

9.1 - GENERAL WARNINGS

HAZARD!

- Maintenance work must be carried out by qualified personnel trained on safety in the workplace and authorised to carry out equipment-related activities.
- Each maintenance operation requires in-depth and specialised knowledge of the equipment, the necessary operations, the associated risks and the correct procedures to operate safely.
- Repair or maintenance work not provided for in this manual may be carried out only if approved by PIETRO FIORENTINI S.p.A.. PIETRO FIORENTINI S.p.A. shall not be held liable for damage to persons or property resulting from operations other than those described herein or carried out in ways other than as indicated.

WARNING!

Before conducting any work, make sure that the line on which the equipment is installed:

- has been shut off downstream and upstream;
- has been discharged.

After discharging the pressure from the line, trigger the slam-shut valve.

WARNING!

In case of doubt, do not perform any work. Contact PIETRO FIORENTINI S.p.A. for the necessary clarifications.

Managing and/or using the equipment includes operations that are necessary as a result of normal use such as:

- inspection and checks;
- functional checks;
- routine maintenance;
- special maintenance.

NOTICE!

Maintenance work is strictly related to:

- **the quality of the conveyed gas (impurities, humidity, gasoline, corrosive substances);**
- **the effectiveness of filtration;**
- **the equipment conditions of use.**

To properly run the equipment, one should:

- follow the service frequency referred to in the manual for functional checks and routine maintenance.
- not exceed the time interval between one service and the next. The time interval is to be understood as the maximum acceptable; it can, however, be shortened;
- promptly check the causes of any anomalies such as excessive noise, leakage of fluids or similar and remedy them. The timely removal of any causes of anomaly and/or malfunction prevents further damage to the equipment and ensures operator safety;

Before beginning disassembly of the equipment, make sure that:

- the spare parts and parts used in replacements have adequate requirements to ensure the original performance of the equipment. Use original, compliant spare parts;
- the operator must have the necessary equipment (see chapter “7 - Commissioning/maintenance equipment”).

! NOTICE!

The recommended spare parts are unambiguously identified with tags indicating:

- **the assembly drawing number of the equipment where they are installed (see Chapter “12 - Recommended spare parts”);**
- **The position specified in the assembly drawing of the equipment.**

The equipment maintenance operations are divided, from an operational point of view, into three main categories:

Commissioning and maintenance operations	
Periodic checks and inspections	All those checks that the operator must carry out on a regular basis to ensure that the equipment is in proper working order.
Routine maintenance	All those operations that the operator must preventively carry out to ensure proper operation of the device over time. Routine maintenance includes: <ul style="list-style-type: none"> • inspection; • control; • adjustment; • cleaning; • lubrication; • replacement; of all spare parts.
Special maintenance	All those operations to be carried out by the operator as required by the equipment.

Tab. 9.51

9.2 - PERIODICALLY CHECKING AND INSPECTING THE EQUIPMENT FOR PROPER OPERATION

Periodic checks and inspections	
Operator qualification	Mechanical maintenance technician
PPE required	 <p>WARNING!</p> <p>The PPE listed in this table is related to the risk associated with the equipment. For the PPE required to protect against risks associated with the workplace, installation or operating conditions, please refer to:</p> <ul style="list-style-type: none"> the regulations in force in the country of installation; <u>any information provided by the Safety Manager at the installation facility.</u>

Tab. 9.52

“Tab. 9.53” lists checks and verifications, i.e. operations that do not require any manual intervention on the individual equipment.

Some items thereof can be replaced remotely using suitable remote control tools. The following is listed below:

Activity description	Equipment/accessories involved	Evaluation criterion	Minimum frequency
Significant performance check*	Pressure regulators	<ul style="list-style-type: none"> No fluctuations in the adjusted pressure. Significant pressure values within pre-set limits. 	Monthly
	Gas flow slam-shut type safety devices (external position indicator)	<ul style="list-style-type: none"> Fully open position. 	
	Stand-by monitor (external position indicator)	<ul style="list-style-type: none"> Fully open position. 	
Visual inspection of the equipment outside condition	All	<ul style="list-style-type: none"> No visible damage. External surface protection as per UNI 9571-1:2012. 	Half-yearly

Tab. 9.53

* These checks may be carried out remotely if there is a remote control system capable of analysing the significant performance of the equipment and of sending alerts/alarms when pre-set thresholds are reached.

9.3 - ROUTINE MAINTENANCE

9.3.1 - GENERAL SAFETY WARNINGS

HAZARD!

- Put the equipment in a safe condition (close the downstream shut-off valve and then the upstream one, and drain the line completely);
- ensure that the pressure upstream and downstream of the equipment is “0”.

WARNING!

After discharging the pressure from the line, trigger the slam-shut valve.

NOTICE!

Before installing new sealing elements (o-rings, diaphragm, etc.), they must be checked for integrity.

9.3.2 - REPLACEMENT FREQUENCY FOR COMPONENTS SUBJECT TO WEAR

NOTICE!

The following provisions shall apply to equipment components only.

The non-metallic parts of the equipment concerned are divided into the following two categories:

Preventive maintenance work

Category 1	Parts subject to wear and/or abrasion, where: <ul style="list-style-type: none"> wear and tear means the normal degradation of a part after prolonged use under normal operating conditions; abrasion is the mechanical action on the surface of the affected part resulting from the passage of gas under normal operating conditions.
Category 2	Parts subject to aging only, including parts that also require lubrication and/or cleaning.

Tab. 9.54

NOTICE!

Check, within the minimum frequency specified in “Tab. 9.55”, the available components for wear/abrasion/aging.

Category	Part description	Evaluation criterion	Minimum replacement frequency
1	Valve seat sealing rings and non-metallic plugs	Pressure regulators	6 years
		Safety devices	
		Pressure safety system equipment	
1	Non-metallic parts with internal sealing function of valve seats and accessories of individual equipment	Pilots	6 years
		Pre-regulators	
		Accelerators	
		Any others	
1	Non-metallic parts with a sealing function between parts, at least one of which is in motion under normal working/operating conditions	Pressure regulators	6 years
		Gas flow slam-shut type safety devices	
		Relief devices with discharge to atmosphere	
1	Non-metallic parts with sealing function involved in disassembly operations during maintenance	Equipment subject to maintenance	6 years
2	Non-metallic parts providing feedback (sensing elements) of the controlled pressure of safety equipment	Safety equipment and/or accessories	6 years
2	Non-metallic parts with sealing and performance functions (diaphragms) of equipment	Pressure regulators and accessories	6 years
		Gas flow slam-shut type safety devices	6 years
		Relief device with discharge to atmosphere	6 years

Category	Part description	Evaluation criterion	Minimum replacement frequency
2	Non-metallic parts of equipment with an internal sealing function: under normal operating conditions during maintenance	Relief valves	6 years
		Regulation lines disconnection equipment	If there are proven leaks
2	Non-metallic parts with a static sealing function only	Various equipment	If there are proven leaks
2	Lubricating parts	Shut-off valves	Yearly
		Other equipment	Yearly
2	Filter elements	Filters	As needed

Tab. 9.55

9.4 - ROUTINE MAINTENANCE PROCEDURES

Routine maintenance	
Operator qualification	Operator qualification
PPE required	 <p>WARNING!</p> <p>The PPE listed in this table is related to the risk associated with the equipment. For the PPE required to protect against risks associated with the workplace, installation or operating conditions, please refer to:</p> <ul style="list-style-type: none"> • the regulations in force in the country of installation; • <u>any information provided by the Safety Manager at the installation facility.</u>
Equipment required	Please refer to the chapter “7 - Commissioning/maintenance equipment”.

Tab. 9.56

9.4.1 - TIGHTENING TORQUES

9.4.1.1 - TIGHTENING TORQUES FOR DIVAL 600 REGULATOR

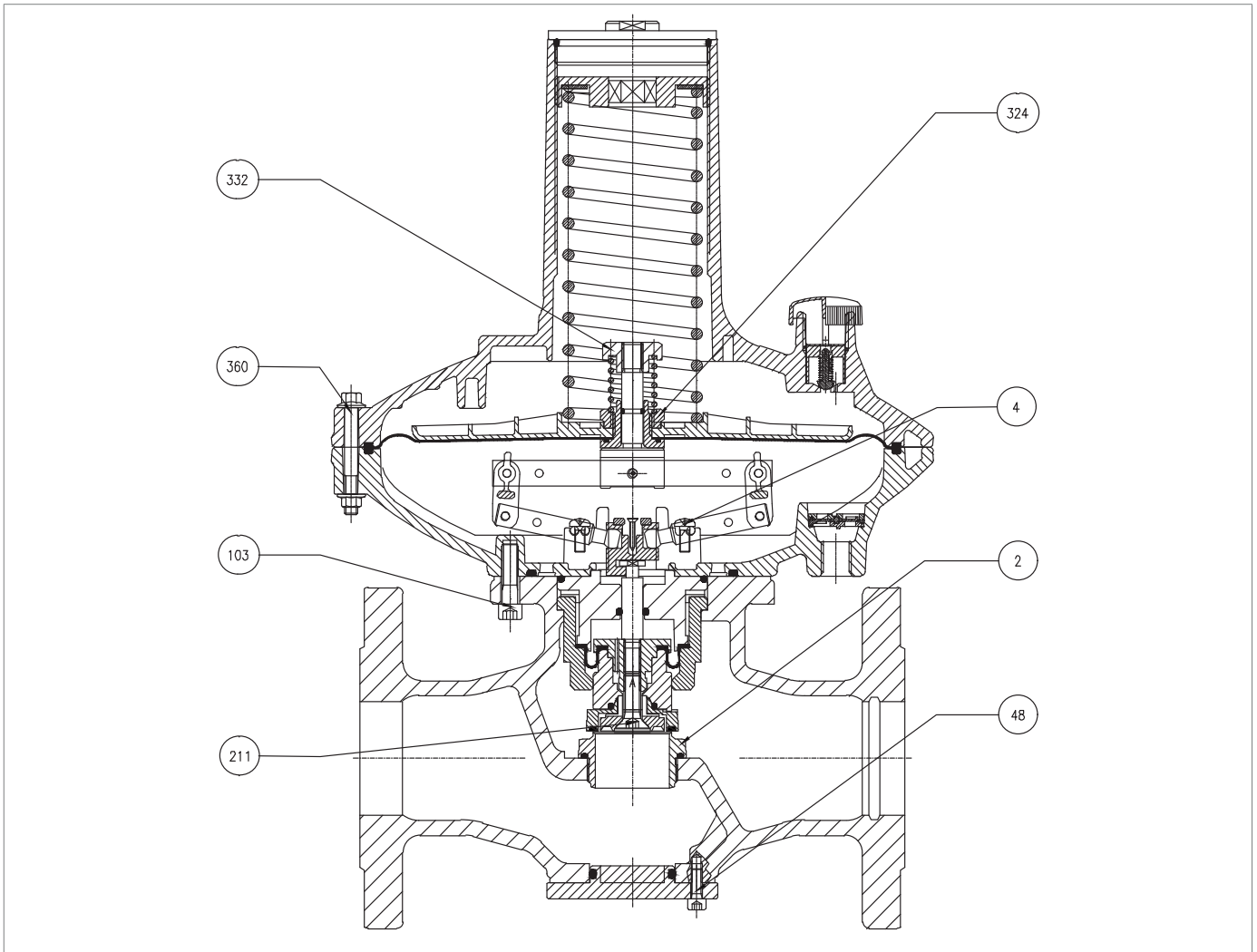

Fig. 9.24. Tightening torques DIVAL 600

DIVAL 600 1" ; 1" ½; 2" - BP, MP, TR HEADS

Pos.	Description	Torque (Nm)	Torque (ft - lb)
2	Valve seat	50	36
4	Screw M5x14 UNI 5931	4	2
48	Screw M5x12 UNI 8111	4	2
103	Screw M8X25 UNI 5931	14	10
211	Screw M8x25 UNI 5933	14	10
324	Fixing nut	14	10
332	Fixing nut	4	2
360	Screw M6x50 DIN 6921	9	6

Tab. 9.57

9.4.1.2 - TIGHTENING TORQUES OF REGULATOR WITH MONITOR FUNCTION

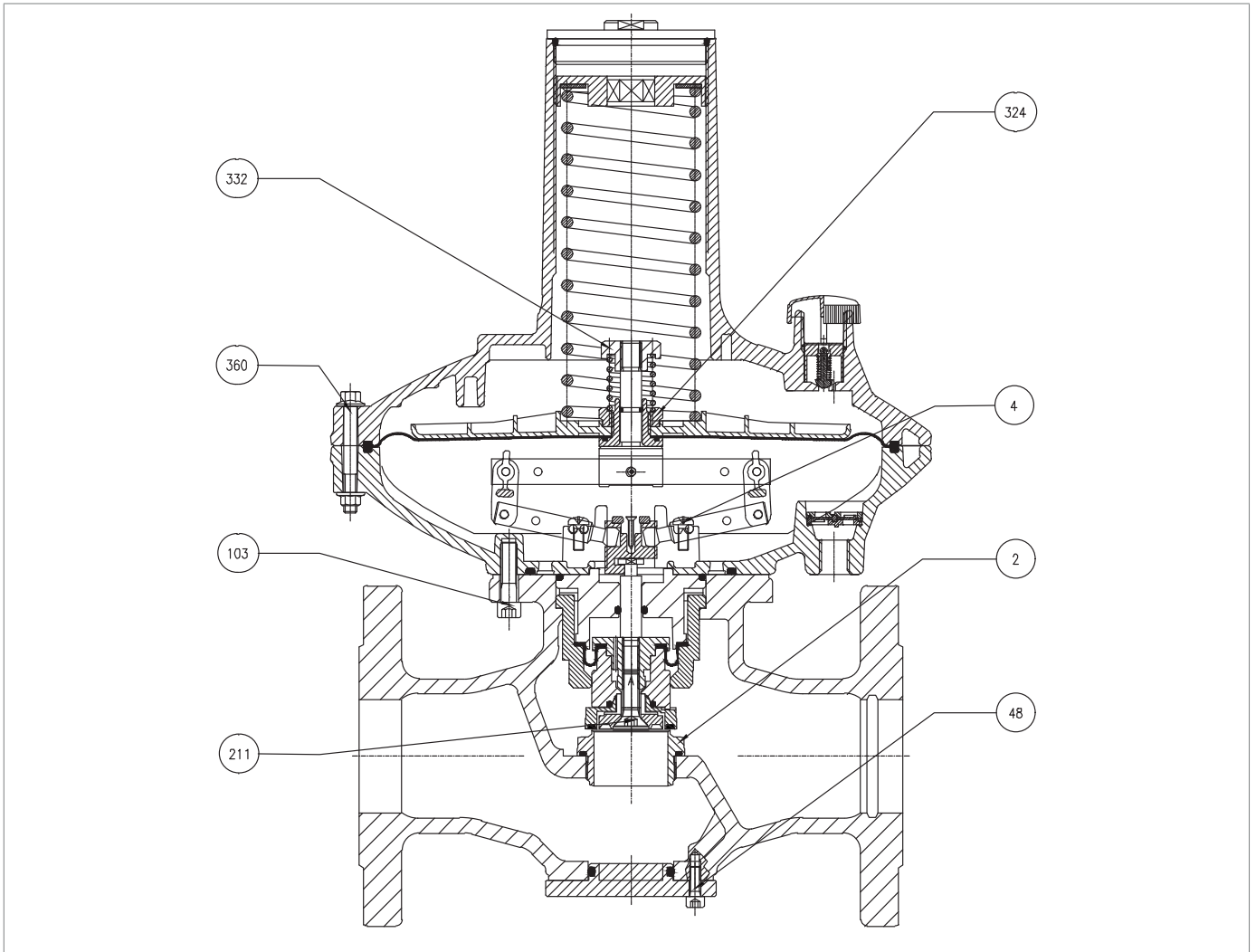

Fig. 9.25. Regulator with monitor function tightening torques

DIVAL 600 WITH MONITOR FUNCTION

Pos.	Description	Torque (Nm)	Torque (ft - lb)
2	Valve seat	50	36
4	Screw M5x14 UNI 5931	4	2
48	Screw M5x12 UNI 8111	4	2
103	Screw M8X25 UNI 5931	14	10
211	Screw M8x25 UNI 5933	14	10
324	Fixing nut	14	10
332	Fixing nut	4	2
360	Screw M6x50 DIN 6921	9	6

Tab. 9.58

9.4.1.3 - TIGHTENING TORQUE LA SLAM-SHUT VALVE

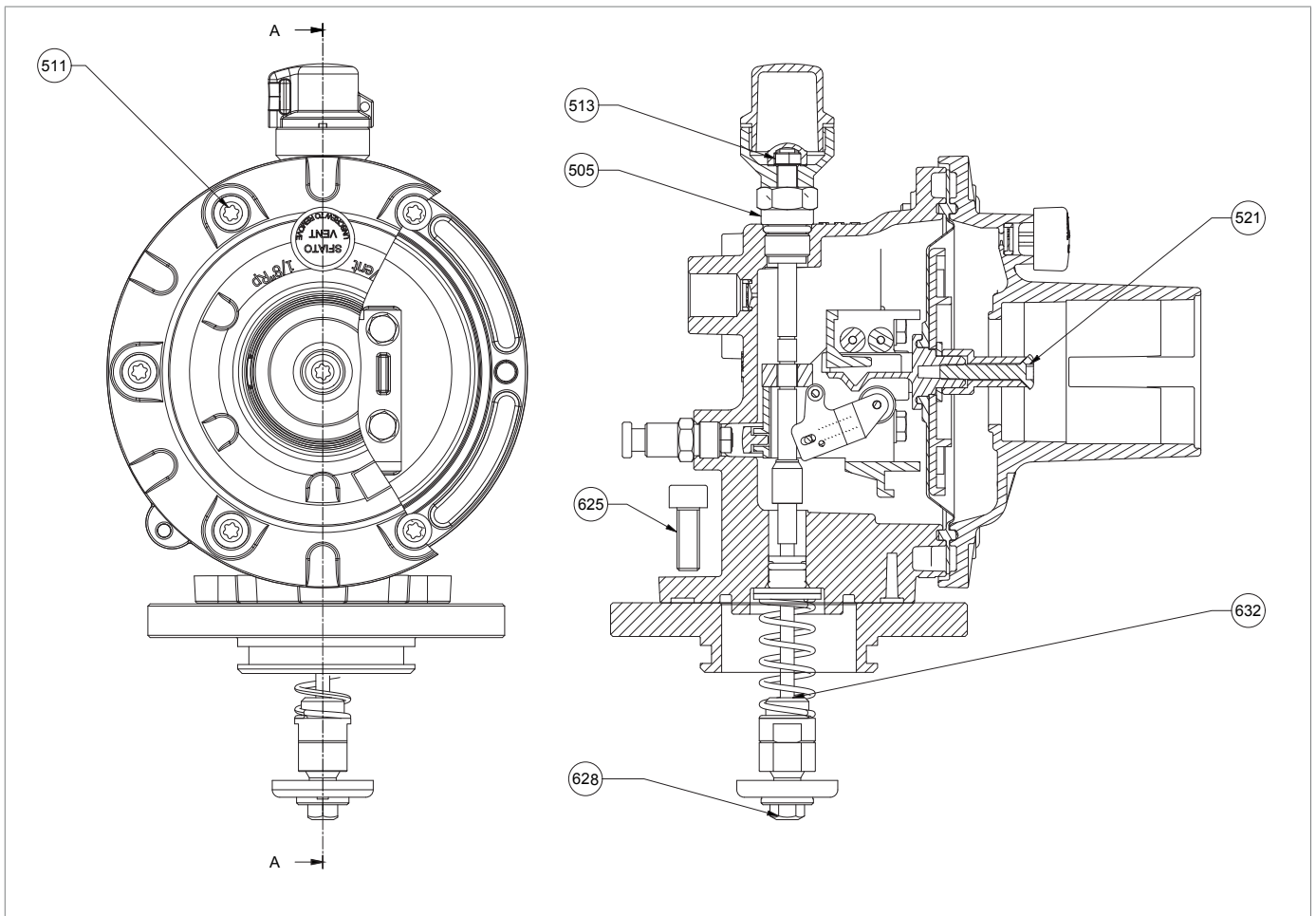

Fig. 9.26. LA Slam-shut valve tightening torques

LA 1" ; 1" ½; 2 - BP, MP, TR HEADS

Pos.	Description	Torque (Nm)	Torque (ft - lb)
505	Rod guide	4.5	3.3
511	TSC M5X20 TORX screw	2.5	1.8
513	M4 nut UNI 5588	1.5	0.8
521	TGS M4X27 TORX screw	4.5	3.3
625	Screw M5X14	4	3
628	Locking nut	1.5	1.1
632	Bushing	1.5	1.1

Tab. 9.59

9.4.2 - REPLACING ELEMENTS SUBJECT TO WEAR AND ABRASION

9.4.2.1 - INITIAL OPERATIONS

⚠ WARNING!

After discharging the pressure from the line, trigger the slam-shut valve.

⚠ ATTENTION!

Before carrying out any work, it is important to ensure that the line on which the regulator is installed has been shut off upstream and downstream, and discharged.

⚠ ATTENTION!

During assembly, make sure to tighten the screws as per the tables (tightening torques), according to the size for which maintenance is being carried out.

Proceed as follows:

Step	Action
1	Unscrew the conical fittings to disconnect all power sockets and sensing lines of the regulator.

Tab. 9.60

9.4.2.2 - CROSS DIAGRAM FOR TIGHTENING SCREWS

To tighten the screws, when required by the maintenance procedure, refer to the following diagram:

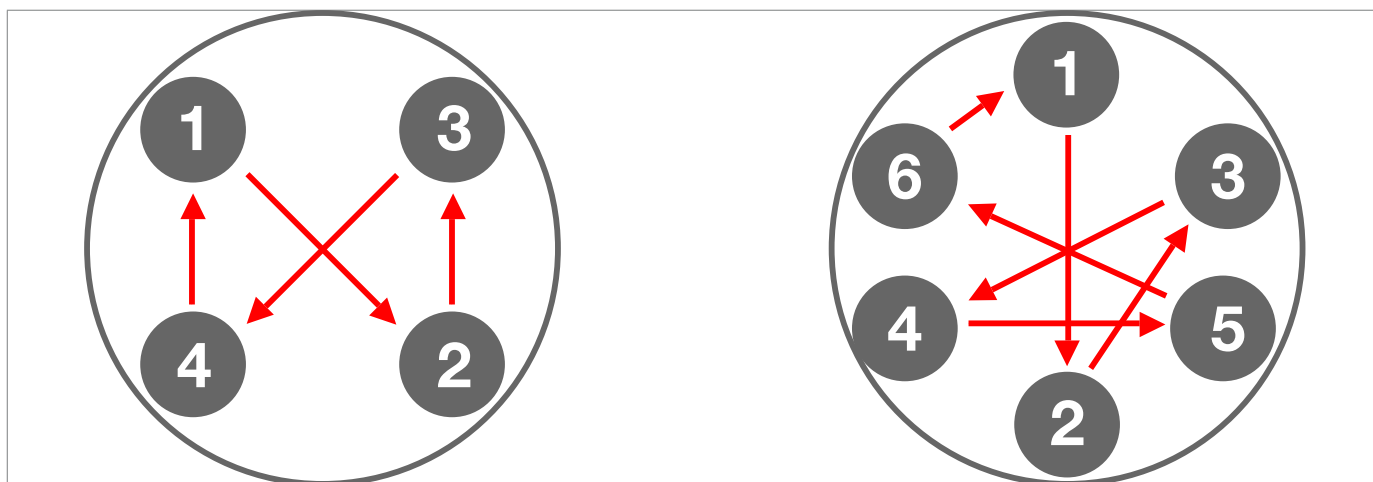

Fig. 9.27. Cross diagram

9.4.3 - REGULATOR DIVAL 600

9.4.3.1 - DIVAL 600 REGULATOR 1" BP/MP HEAD

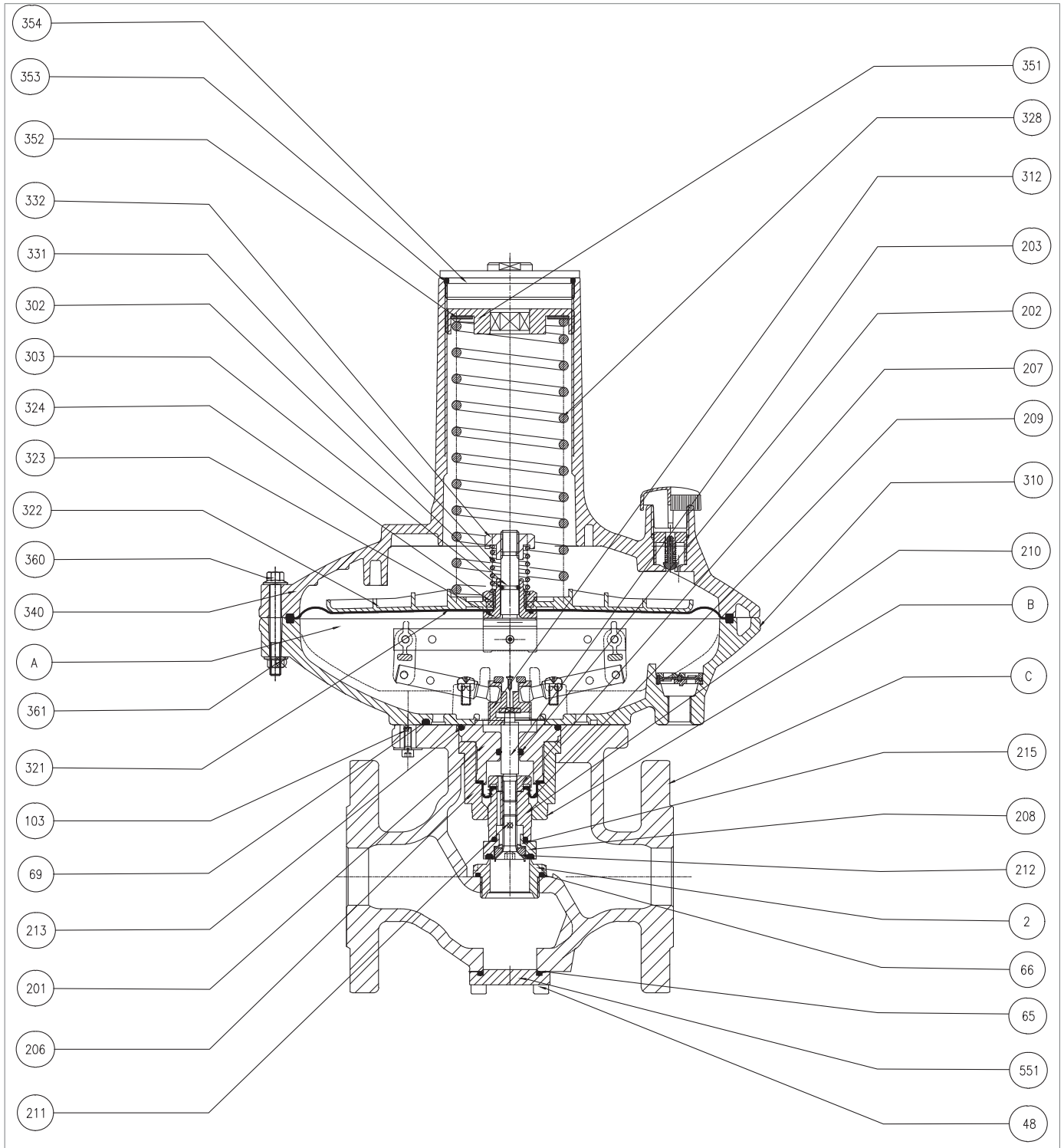







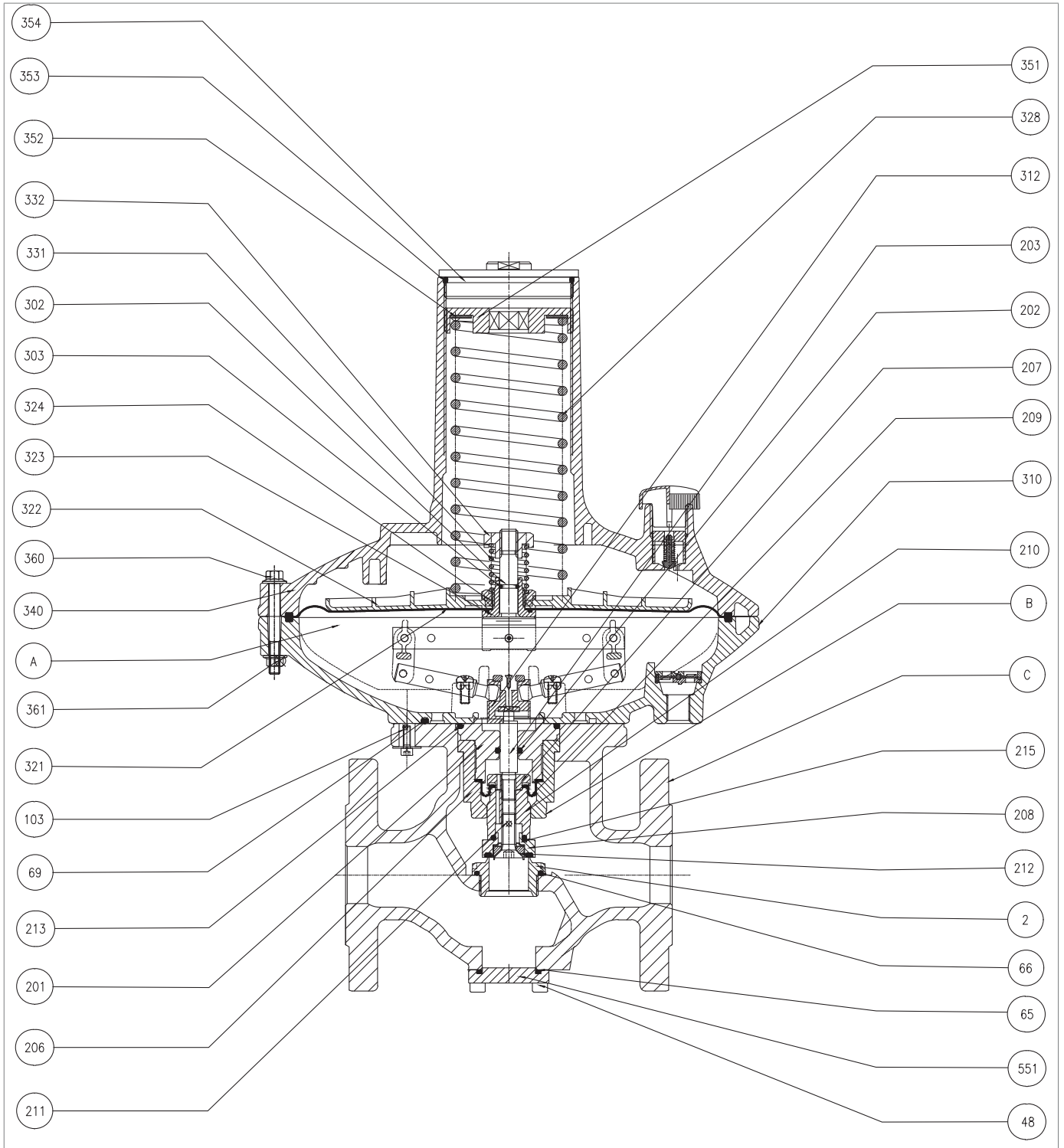

Fig. 9.28. DIVAL 600 Regulator 1", BP/MP head

Step	Action
1	Unscrew and remove the cap (354).
2	Remove the O-ring (353) and replace it, taking care to lubricate it with synthetic grease. <div style="border: 1px solid black; padding: 5px;">  NOTICE! </div> Before inserting the replacement O-ring, clean the retaining slots with a cleaning solution.
3	Unscrew and remove the ring nut (351) together with the washer (352). <div style="border: 1px solid black; padding: 5px;">  NOTICE! </div> Turn the ring nut anti-clockwise.
4	Remove the regulation spring (328).
5	Unscrew and remove the screws (103) securing the control head (A) to the body (C).
6	Remove the control head (A) together with the balancing block (B).
7	Separate the balancing block (B) from the control head (A). <div style="border: 1px solid black; padding: 5px;">  NOTICE! </div> Follow the direction of the arrow on the lower cover (310).
8	Unscrew and remove the nuts (361).
9	Undo and remove the screws (360).
10	Remove the upper cover (340) from the lower cover (310).
11	Unscrew and remove the locking nut (332).
12	Pull out the spring (331) of the relief valve.
13	Pull the diaphragm support assembly (321, 322, 323, 324) off the rod (302).
14	Remove the O-ring (303) and replace it, taking care to lubricate it with synthetic grease. <div style="border: 1px solid black; padding: 5px;">  NOTICE! </div> Before inserting the replacement O-ring, clean the retaining slots with a cleaning solution.
15	Unscrew and remove the locking nut (324). <div style="border: 1px solid black; padding: 5px;">  NOTICE! </div> During this phase, keep the diaphragm support (323) still.
16	Remove the diaphragm protection disc (322).
17	Remove and replace the main diaphragm (321).
18	Fit the diaphragm protection disc (322).
19	Insert and secure the locking nut (324), according to the tightening torques: <ul style="list-style-type: none"> • “Tab. 9.57” <div style="border: 1px solid black; padding: 5px;">  NOTICE! </div> During this phase, keep the diaphragm support (323) still.
20	Position the diaphragm support assembly (321, 322, 323, 324, 390) in the rod (302).
21	Insert the spring (331) of the relief valve.
22	Insert and fix the nut (332) according to the following tightening torques: <ul style="list-style-type: none"> • “Tab. 9.57”
23	Place the upper cover (340) on the lower cover (310). <div style="border: 1px solid black; padding: 5px;">  NOTICE! </div> Follow the orientation of the anti-pumping valve when positioning the cover.





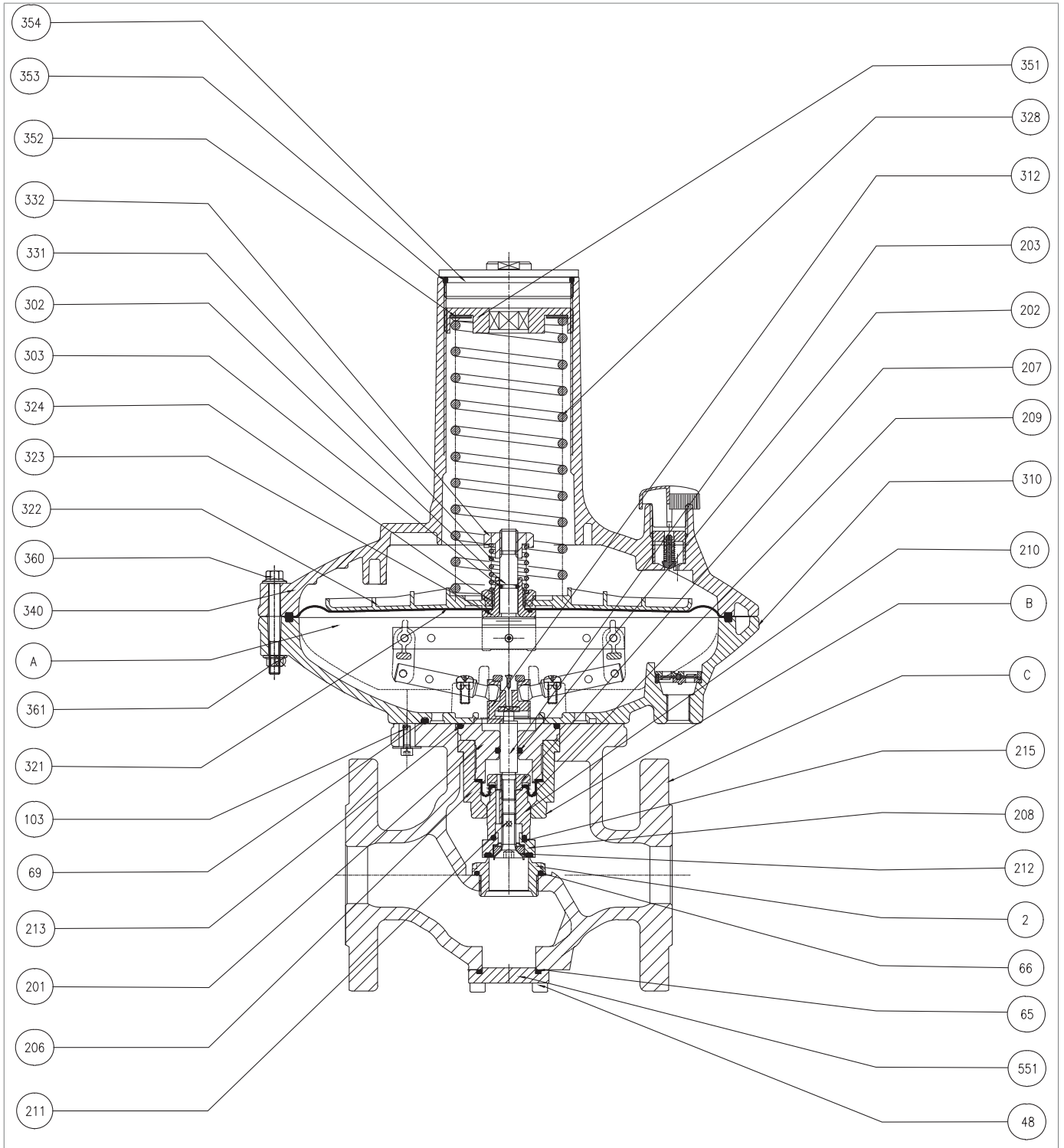

DIVAL 600 Regulator 1", BP/MP head

Step	Action
24	<p>Insert and fix the screws (360) together with the nuts (361) according to the following tightening torques:</p> <ul style="list-style-type: none"> • “Tab. 9.57” <p>NOTICE!</p> <p>Screw in as shown in the diagram at “9.4.2.2 - Cross diagram for tightening screws”.</p>
25	<p>Unscrew and remove the fixing screw (211).</p> <p>NOTICE!</p> <p>During this phase, keep the rod (203) still.</p>
26	<p>Remove the plug (208) together with the O-ring (215) and plug ring (212).</p>
27	<p>Remove the O-ring (215) and replace it, taking care to lubricate it with synthetic grease.</p> <p>NOTICE!</p> <p>Before inserting the replacement O-ring, clean the retaining slots with a cleaning solution.</p>
28	<p>Pull out the bushing (206).</p>
29	<p>Remove the spacer (210).</p>
30	<p>Remove the diaphragm (209).</p>
31	<p>Remove the O-ring (213) and replace it, taking care to lubricate it with synthetic grease.</p> <p>NOTICE!</p> <p>Before inserting the replacement O-ring, clean the retaining slots with a cleaning solution.</p>
32	<p>Slide off the diaphragm protection disc (207).</p> <p>NOTICE!</p> <p>During this phase, keep the rod (203) still.</p>
33	<p>Slide the rod guide (201) off the rod (203).</p>
34	<p>Remove the O-ring (202) and replace it, taking care to lubricate it with synthetic grease.</p> <p>NOTICE!</p> <p>Before inserting the replacement O-ring, clean the retaining slots with a cleaning solution.</p>
35	<p>Insert the rod guide (201) into the rod (203).</p>
36	<p>Put the diaphragm protection disc (207) back in place.</p> <p>NOTICE!</p> <p>During this phase, keep the rod (203) still.</p>
37	<p>Insert the diaphragm (209) onto the diaphragm protection disc (207).</p>
38	<p>Place the spacer (210) in the rod (203).</p>
39	<p>Position the O-ring (215) and the bushing (206).</p>
40	<p>Insert plug (208), plug ring (212) on spacer (210).</p>
41	<p>Insert and fix the screw (211) according to the tightening torques:</p> <ul style="list-style-type: none"> • “Tab. 9.57” <p>NOTICE!</p> <p>When fastening, align the mechanical stop on the surface.</p>
42	<p>Unscrew and remove the valve seat (2) together with the O-ring (66).</p>



DIVAL 600 Regulator 1", BP/MP head

Step	Action
43	Remove the O-ring (66) and replace it, taking care to lubricate it with synthetic grease. <div style="border: 1px solid blue; padding: 2px;">  NOTICE! Before inserting the replacement O-ring, clean the retaining slots with a cleaning solution. </div>
44	Insert the valve seat (2) together with the O-ring (66) into the body (C) according to the tightening torques: <ul style="list-style-type: none"> • “Tab. 9.57”
45	Remove the O-ring (69) and replace it, taking care to lubricate it with synthetic grease. <div style="border: 1px solid blue; padding: 2px;">  NOTICE! Before inserting the replacement O-ring, clean the retaining slots with a cleaning solution. </div>
46	Position the balancing block (B) in the control head (A). <div style="border: 1px solid blue; padding: 2px;">  NOTICE! In the opposite direction indicated by the arrow on the lower cover (310). </div>
47	Position the control head (A) and the balancing block (B) in the housing (C).
48	Insert and fasten the screws (103) that secure the control head (A) to the body (C) according to the tightening torques: <ul style="list-style-type: none"> • “Tab. 9.57” <div style="border: 1px solid blue; padding: 2px;">  NOTICE! Screw in as shown in the diagram at “9.4.2.2 - Cross diagram for tightening screws”. </div>
49	Insert the regulation spring (328).
50	Insert and secure the adjustment ring nut (351) together with the washer (352).
51	Insert and secure the plug (354) together with the O-ring (353).
52	Undo and remove the lower screws (48).
53	Remove the flange (551) together with the O-ring (65).
54	Remove the O-ring (65) and replace it, taking care to lubricate it with synthetic grease. <div style="border: 1px solid blue; padding: 2px;">  NOTICE! Before inserting the replacement O-rings, clean the retaining slots with a cleaning solution. </div>
55	Position the flange (551) together with the O-ring (65).
56	Insert and fix the lower screws (48) according to the following tightening torques: <ul style="list-style-type: none"> • “Tab. 9.57” <div style="border: 1px solid blue; padding: 2px;">  NOTICE! Screw in as shown in the diagram at “9.4.2.2 - Cross diagram for tightening screws”. </div>

Tab. 9.61

 **WARNING!**
Ensure that all parts have been fitted correctly.

9.4.3.2 - DIVAL 600 REGULATOR 1" TR HEAD

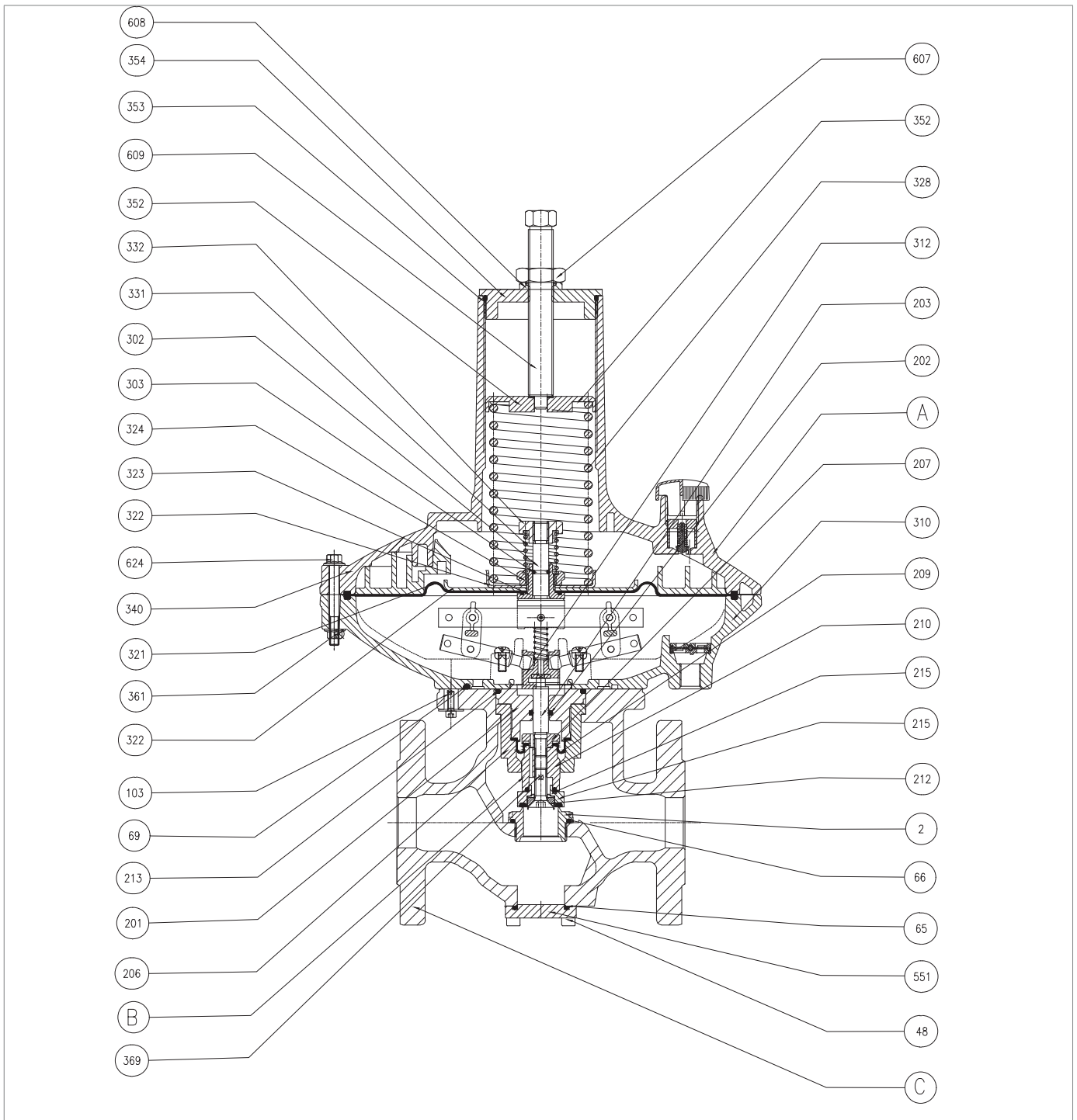
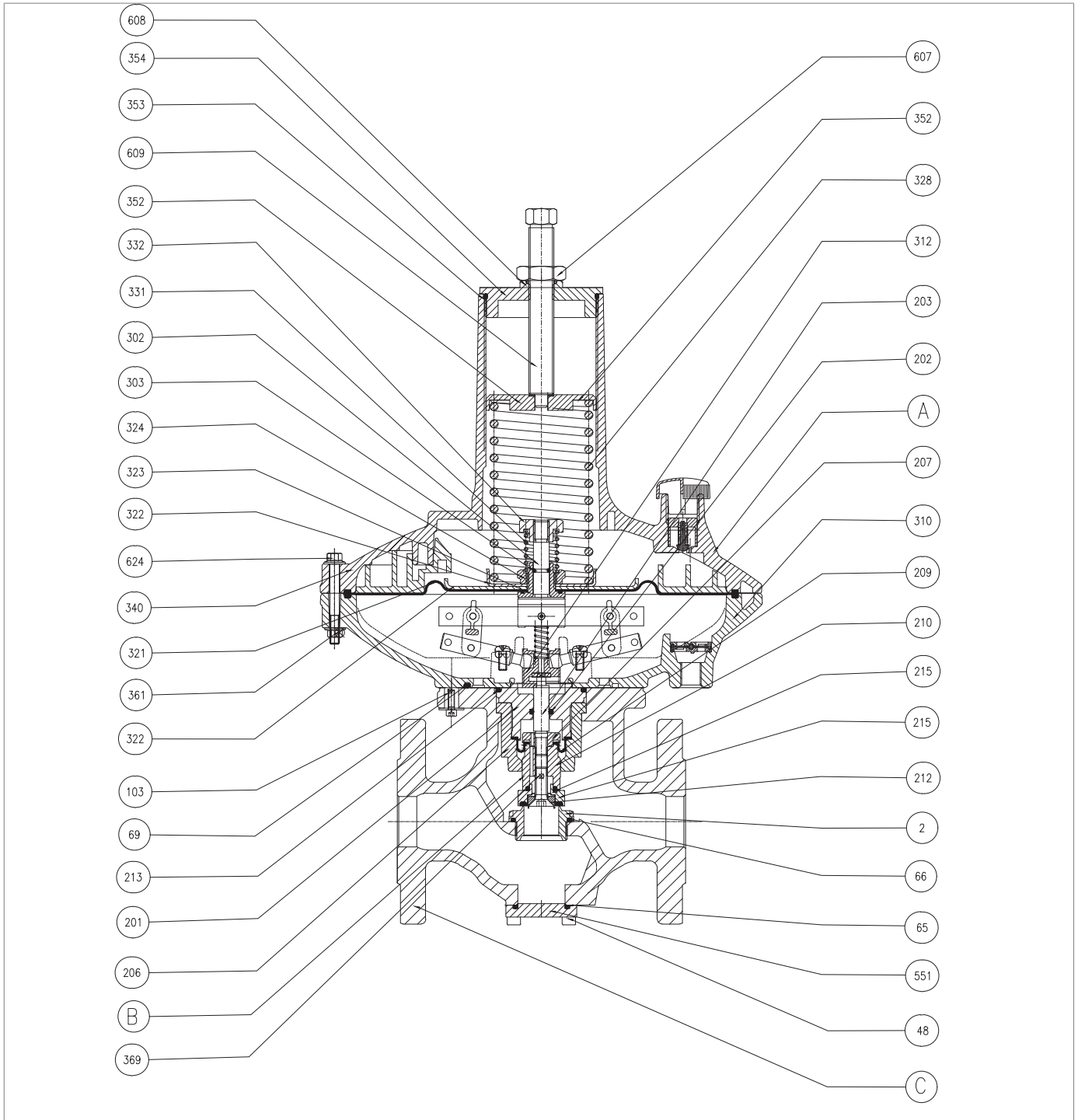









Fig. 9.29. DIVAL 600 Regulator 1", TR head

Step	Action
1	Unscrew and remove the adjusting screw (609) together with the locking nut (607).
2	Remove and replace the O-rings (353, 608), taking care to lubricate them with synthetic grease. NOTICE! Before inserting the replacement O-rings, clean the retaining slots with a cleaning solution.
3	Remove the spring guide disc (610) together with the washer (352).
4	Remove the regulation spring (328).
5	Unscrew and remove the screws (103) securing the control head (A) to the body (C).
6	Remove the control head (A) together with the balancing block (B).
7	Separate the balancing block (B) from the control head (A). NOTICE! Follow the indication of the arrow.
8	Unscrew and remove the nuts (361).
9	Undo and remove the screws (360).
10	Remove the upper cover (340) from the lower cover (310).
11	Unscrew and remove the locking nut (332).
12	Pull out the spring (331) of the relief valve.
13	Pull the diaphragm support assembly (321, 322, 323, 324) off the rod (302).
14	Remove the O-ring (303) and replace it, taking care to lubricate it with synthetic grease. NOTICE! Before inserting the replacement O-ring, clean the retaining slots with a cleaning solution.
15	Unscrew and remove the locking nut (324). NOTICE! During this phase, keep the diaphragm support (323) still.
16	Remove the diaphragm protection disc (322).
17	Remove and replace the main diaphragm (321).
18	Fit the diaphragm protection disc (322).
19	Insert and secure the locking nut (324), according to the tightening torques: • "Tab. 9.57" NOTICE! During this phase, keep the diaphragm support (323) still.
20	Position the diaphragm support assembly (321, 322, 323, 324, 390) in the rod (302).
21	Insert the spring (331) of the relief valve.
22	Insert and fix the nut (332) according to the following tightening torques: • "Tab. 9.57"
23	Place the upper cover (340) on the lower cover (310). NOTICE! Follow the orientation of the anti-pumping valve when positioning the cover.







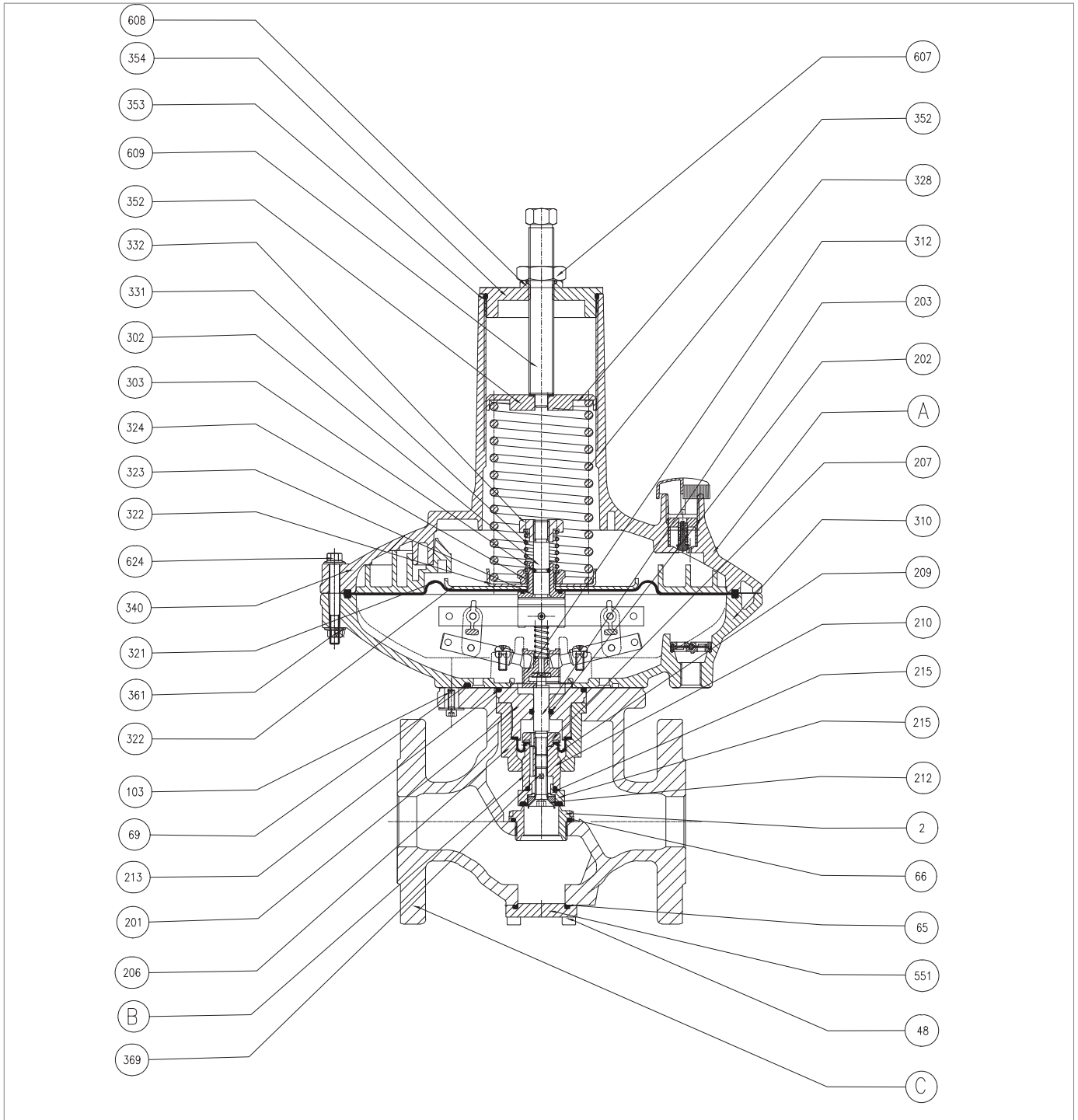

DIVAL 600 Regulator 1", TR head

Step	Action
24	Insert and fix the screws (360) together with the nuts (361) according to the following tightening torques: <ul style="list-style-type: none"> • “Tab. 9.57” <div style="border: 1px solid black; padding: 5px;">  NOTICE! </div> Screw in as shown in the diagram at “9.4.2.2 - Cross diagram for tightening screws”.
25	Unscrew and remove the fixing screw (211). <div style="border: 1px solid black; padding: 5px;">  NOTICE! </div> During this phase, keep the rod (203) still.
26	Remove the plug (208) together with the O-ring (215) and plug ring (212).
27	Remove the O-ring (215) and replace it, taking care to lubricate it with synthetic grease. <div style="border: 1px solid black; padding: 5px;">  NOTICE! </div> Before inserting the replacement O-ring, clean the retaining slots with a cleaning solution.
28	Remove the bushing (206).
29	Unscrew the spacer (210)
30	Remove the diaphragm (209).
31	Remove the O-ring (213) and replace it, taking care to lubricate it with synthetic grease. <div style="border: 1px solid black; padding: 5px;">  NOTICE! </div> Before inserting the replacement O-ring, clean the retaining slots with a cleaning solution.
32	Unscrew the diaphragm protection disc (207). <div style="border: 1px solid black; padding: 5px;">  NOTICE! </div> During this phase, keep the rod (203) still.
33	Slide the rod guide (201) off the rod (203).
34	Remove the O-ring (202) and replace it, taking care to lubricate it with synthetic grease. <div style="border: 1px solid black; padding: 5px;">  NOTICE! </div> Before inserting the replacement O-ring, clean the retaining slots with a cleaning solution.
35	Insert the rod guide (201) into the rod (203).
36	Put the diaphragm protection disc (207) back in place. <div style="border: 1px solid black; padding: 5px;">  NOTICE! </div> During this phase, keep the rod (203) still.
37	Insert the diaphragm (209) onto the diaphragm protection disc (207).
38	Insert and secure the spacer (210).
39	Position the O-ring (215) and the bushing (206).
40	Insert plug (208), plug ring (212) on spacer (210).
41	Insert and fix the screw (211) according to the tightening torques: <ul style="list-style-type: none"> • “Tab. 9.57” <div style="border: 1px solid black; padding: 5px;">  NOTICE! </div> When fastening, align the mechanical stop on the surface.
42	Unscrew and remove the valve seat (2) together with the O-ring (66).



DIVAL 600 Regulator 1", TR head

Step	Action
43	Remove the O-ring (66) and replace it, taking care to lubricate it with synthetic grease. <div style="border: 1px solid black; padding: 2px;">  NOTICE! Before inserting the replacement O-ring, clean the retaining slots with a cleaning solution. </div>
44	Insert the valve seat (2) together with the O-ring (66) into the body (C) according to the tightening torques: <ul style="list-style-type: none"> • “Tab. 9.57”
45	Remove the O-ring (69) and replace it, taking care to lubricate it with synthetic grease. <div style="border: 1px solid black; padding: 2px;">  NOTICE! Before inserting the replacement O-ring, clean the retaining slots with a cleaning solution. </div>
46	Position the balancing block (B) in the control head (A). <div style="border: 1px solid black; padding: 2px;">  NOTICE! In the opposite direction indicated by the arrow on the lower cover (310). </div>
47	Position the control head (A) and the balancing block (B) in the housing (C).
48	Insert and fasten the screws (103) that secure the control head (A) to the body (C) according to the tightening torques: <ul style="list-style-type: none"> • “Tab. 9.57” <div style="border: 1px solid black; padding: 2px;">  NOTICE! Screw in as shown in the diagram at “9.4.2.2 - Cross diagram for tightening screws”. </div>
49	Insert the regulation spring (328).
50	Insert the spring guide disc (610) together with washer (352).
51	Insert and secure the cap (354) together with the O-rings (353, 608).
52	Insert the adjusting screw (609) together with the locking nut (607) into the cap (354). <div style="border: 1px solid black; padding: 2px;">  AVVISO! Before inserting the screw, lubricate it with synthetic grease. </div>
53	Undo and remove the lower screws (48).
54	Remove the flange (551) together with the O-ring (65).
55	Remove the O-ring (65) and replace it, taking care to lubricate it with synthetic grease. <div style="border: 1px solid black; padding: 2px;">  NOTICE! Before inserting the replacement O-rings, clean the retaining slots with a cleaning solution. </div>
56	Position the flange (551) together with the O-ring (65).
57	Insert and fix the lower screws (48) according to the following tightening torques: <ul style="list-style-type: none"> • “Tab. 9.57” <div style="border: 1px solid black; padding: 2px;">  NOTICE! Screw in as shown in the diagram at “9.4.2.2 - Cross diagram for tightening screws”. </div>

Tab. 9.62

 **WARNING!**
Ensure that all parts have been fitted correctly.

9.4.3.3 - DIVAL 600 REGULATOR 1" 1/2 2" BP/MP HEAD

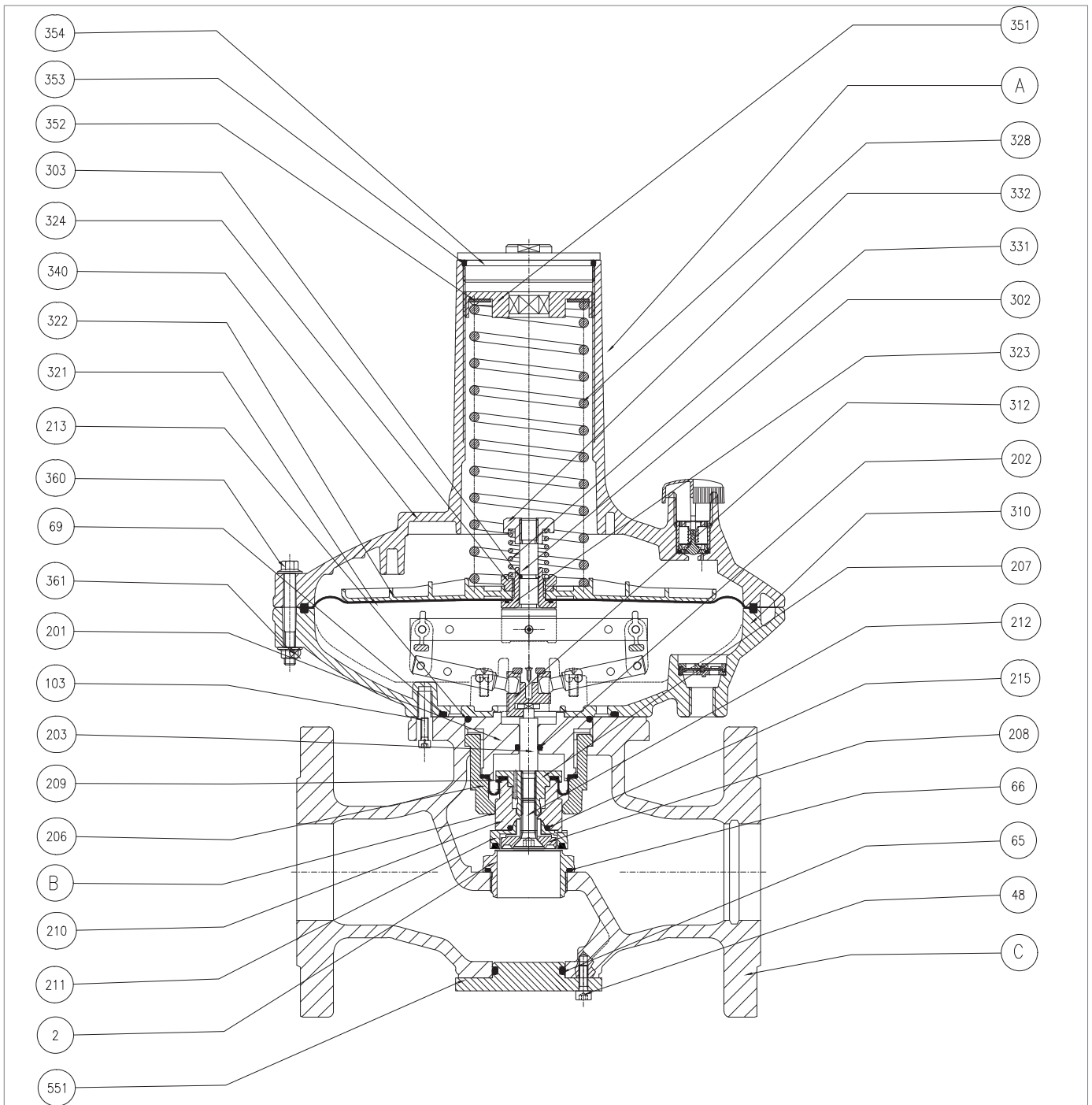







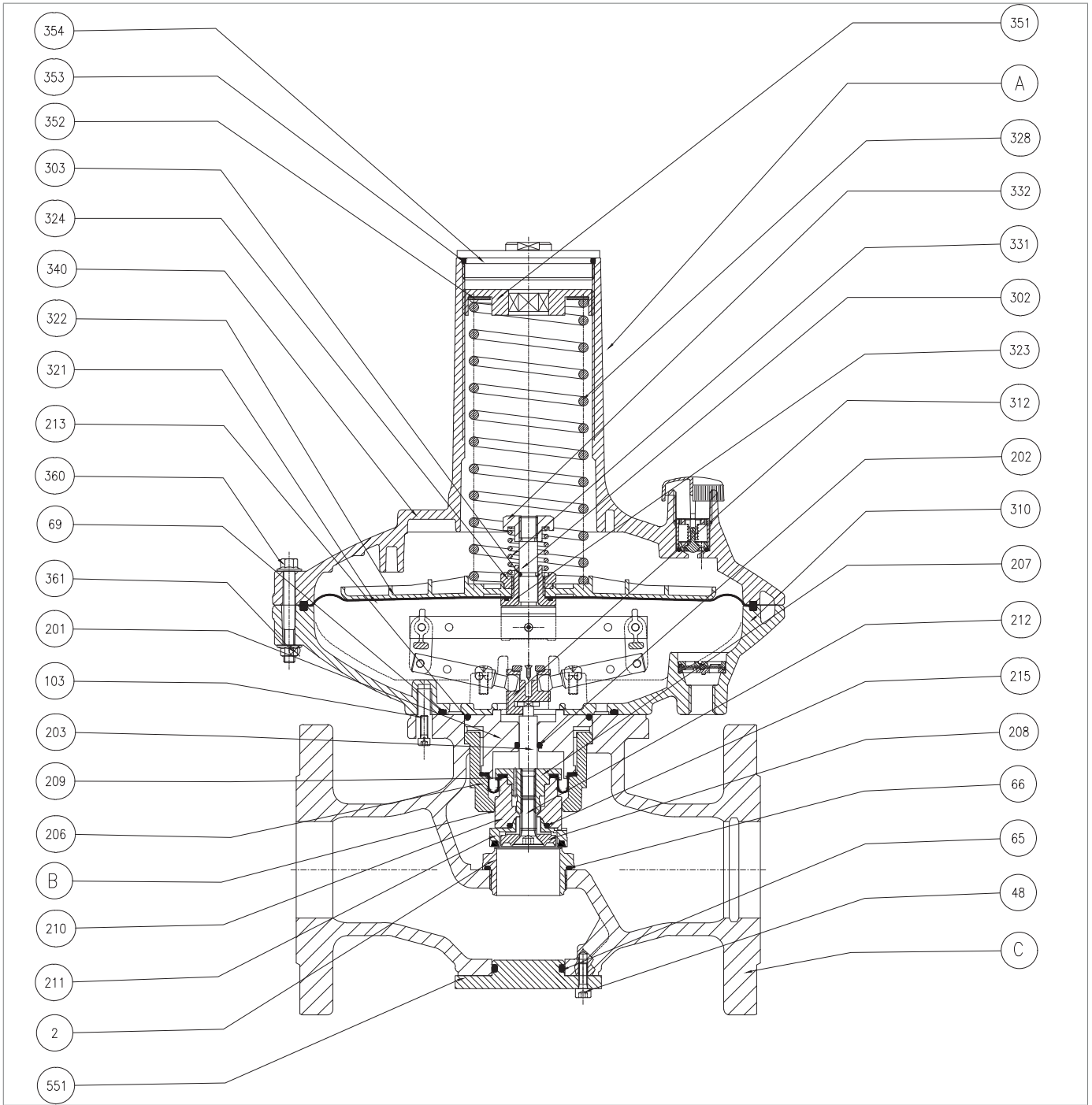











Fig. 9.30. DIVAL 600 regulator 1" 1/2 2", BP/MP head

Step	Action
1	Unscrew and remove the cap (354).
2	Remove the O-ring (353) and replace it, taking care to lubricate it with synthetic grease.  NOTICE! Before inserting the replacement O-ring, clean the retaining slots with a cleaning solution.
3	Unscrew and remove the ring nut (351) together with the washer (352).  NOTICE! Turn the ring nut anti-clockwise.
4	Remove the regulation spring (328).
5	Unscrew and remove the screws (103) securing the control head (A) to the body (C).
6	Remove the control head (A) together with the balancing block (B).
7	Separate the balancing block (B) from the control head (A).  NOTICE! Follow the indication of the arrow.
8	Unscrew and remove the nuts (361).
9	Undo and remove the screws (360).
10	Remove the upper cover (340) from the lower cover (310).
11	Unscrew and remove the locking nut (332).
12	Pull out the spring (331) of the relief valve.
13	Pull the diaphragm support assembly (321, 322, 323, 324) off the rod (302).
14	Remove the O-ring (303) and replace it, taking care to lubricate it with synthetic grease.  NOTICE! Before inserting the replacement O-ring, clean the retaining slots with a cleaning solution.
15	Unscrew and remove the locking nut (324).  NOTICE! During this phase, keep the diaphragm support (323) still.
16	Remove the diaphragm protection disc (322).
17	Remove and replace the main diaphragm (321).
18	Fit the diaphragm protection disc (322).
19	Insert and secure the locking nut (324), according to the tightening torques: <ul style="list-style-type: none"> • “Tab. 9.57”  NOTICE! During this phase, keep the diaphragm support (323) still.
20	Position the diaphragm support assembly (321, 322, 323, 324, 390) in the rod (302).
21	Insert the spring (331) of the relief valve.
22	Insert and fix the nut (332) according to the following tightening torques: <ul style="list-style-type: none"> • “Tab. 9.57”
23	Place the upper cover (340) on the lower cover (310).  NOTICE! Follow the orientation of the anti-pumping valve when positioning the cover.



DIVAL 600 regulator 1" 1/2 2", BP/MP head

Step	Action
24	Insert and fix the screws (360) together with the nuts (361) according to the following tightening torques: <ul style="list-style-type: none"> • “Tab. 9.57” <div style="border: 1px solid black; padding: 5px;">  NOTICE! </div> <p>Screw in as shown in the diagram at “9.4.2.2 - Cross diagram for tightening screws”.</p>
25	Unscrew and remove the fixing screw (211). <div style="border: 1px solid black; padding: 5px;">  NOTICE! </div> <p>During this phase, keep the rod (203) still.</p>
26	Remove the plug (208) together with the O-ring (215) and plug ring (212).
27	Remove the O-ring (215) and replace it, taking care to lubricate it with synthetic grease. <div style="border: 1px solid black; padding: 5px;">  NOTICE! </div> <p>Before inserting the replacement O-ring, clean the retaining slots with a cleaning solution.</p>
28	Remove the bushing (206), spacer (210) and diaphragm (209).
29	Remove the O-ring (213) and replace it, taking care to lubricate it with synthetic grease. <div style="border: 1px solid black; padding: 5px;">  NOTICE! </div> <p>Before inserting the replacement O-ring, clean the retaining slots with a cleaning solution.</p>
30	Unscrew the diaphragm protection disc (207). <div style="border: 1px solid black; padding: 5px;">  NOTICE! </div> <p>During this phase, keep the rod (203) still.</p>
31	Slide the rod guide (201) off the rod (203).
32	Remove the O-ring (202) and replace it, taking care to lubricate it with synthetic grease. <div style="border: 1px solid black; padding: 5px;">  NOTICE! </div> <p>Before inserting the replacement O-ring, clean the retaining slots with a cleaning solution.</p>
33	Insert the rod guide (201) into the rod (203).
34	Put the diaphragm protection disc (207) back in place. <div style="border: 1px solid black; padding: 5px;">  NOTICE! </div> <p>During this phase, keep the rod (203) still.</p>
35	Insert the diaphragm (209) onto the diaphragm protection disc (207).
36	Position the plug support (210) together with the O-ring (215) and the bushing (206).
37	Insert plug (208), plug ring (212) on spacer (210).
38	Insert and fix the screw (211) according to the tightening torques: <ul style="list-style-type: none"> • “Tab. 9.57” <div style="border: 1px solid black; padding: 5px;">  NOTICE! </div> <p>When fastening, align the mechanical stop on the surface.</p>
39	Remove the O-ring (66) and replace it, taking care to lubricate it with synthetic grease. <div style="border: 1px solid black; padding: 5px;">  NOTICE! </div> <p>Before inserting the replacement O-ring, clean the retaining slots with a cleaning solution.</p>
40	Unscrew and remove the valve seat (2) together with the O-ring (66).

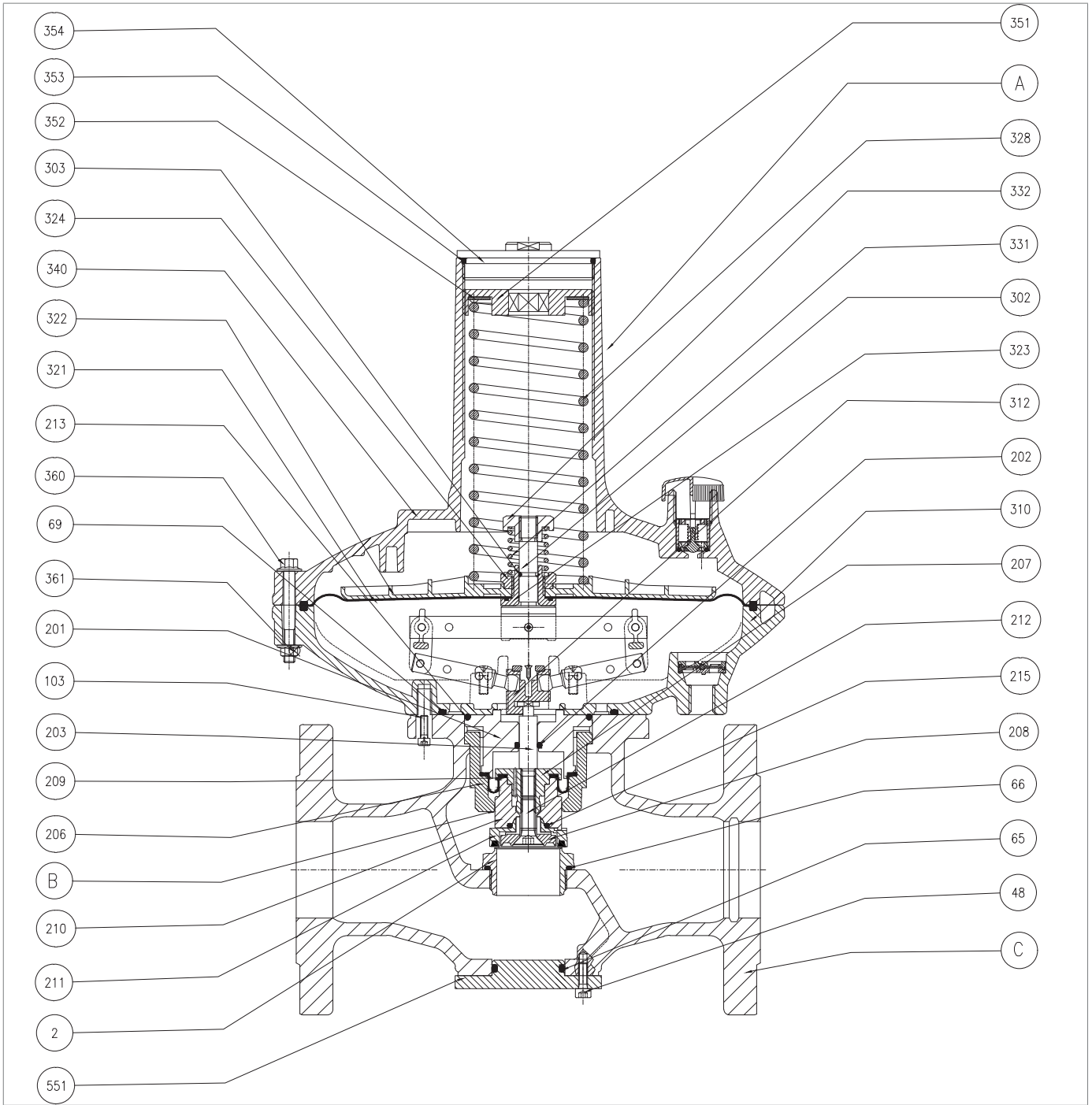

DIVAL 600 regulator 1" 1/2 2", BP/MP head

Step	Action
41	Insert the valve seat (2) together with the O-ring (66) into the body (C) according to the tightening torques: <ul style="list-style-type: none"> • “Tab. 9.57”
42	Remove the O-ring (69) and replace it, taking care to lubricate it with synthetic grease. <div style="border: 1px solid black; padding: 5px;"> <p>! NOTICE! Before inserting the replacement O-ring, clean the retaining slots with a cleaning solution.</p> </div>
43	Position the balancing block (B) in the control head (A). <div style="border: 1px solid black; padding: 5px;"> <p>! NOTICE! In the opposite direction indicated by the arrow on the lower cover (310).</p> </div>
44	Position the control head (A) and the balancing block (B) in the housing (C).
45	Insert and fasten the screws (103) that secure the control head (A) to the body (C) according to the tightening torques: <ul style="list-style-type: none"> • “Tab. 9.57” <div style="border: 1px solid black; padding: 5px;"> <p>! NOTICE! Screw in as shown in the diagram at “9.4.2.2 - Cross diagram for tightening screws”.</p> </div>
46	Insert the regulation spring (328).
47	Insert and secure the adjustment ring nut (351) together with the washer (352).
48	Insert and secure the plug (354) together with the O-ring (353).
49	Undo and remove the lower screws (48).
50	Remove the flange (551) together with the O-ring (65).
51	Remove the O-ring (65) and replace it, taking care to lubricate it with synthetic grease. <div style="border: 1px solid black; padding: 5px;"> <p>! NOTICE! Before inserting the replacement O-rings, clean the retaining slots with a cleaning solution.</p> </div>
52	Position the flange (551) together with the O-ring (65).
53	Insert and fix the lower screws (48) according to the following tightening torques: <ul style="list-style-type: none"> • “Tab. 9.57” <div style="border: 1px solid black; padding: 5px;"> <p>! NOTICE! Screw in as shown in the diagram at “9.4.2.2 - Cross diagram for tightening screws”.</p> </div>

Tab. 9.63

! WARNING!
Ensure that all parts have been fitted correctly.

9.4.3.4 - DIVAL 600 REGULATOR 1" 1/2 ; 2" TR HEAD

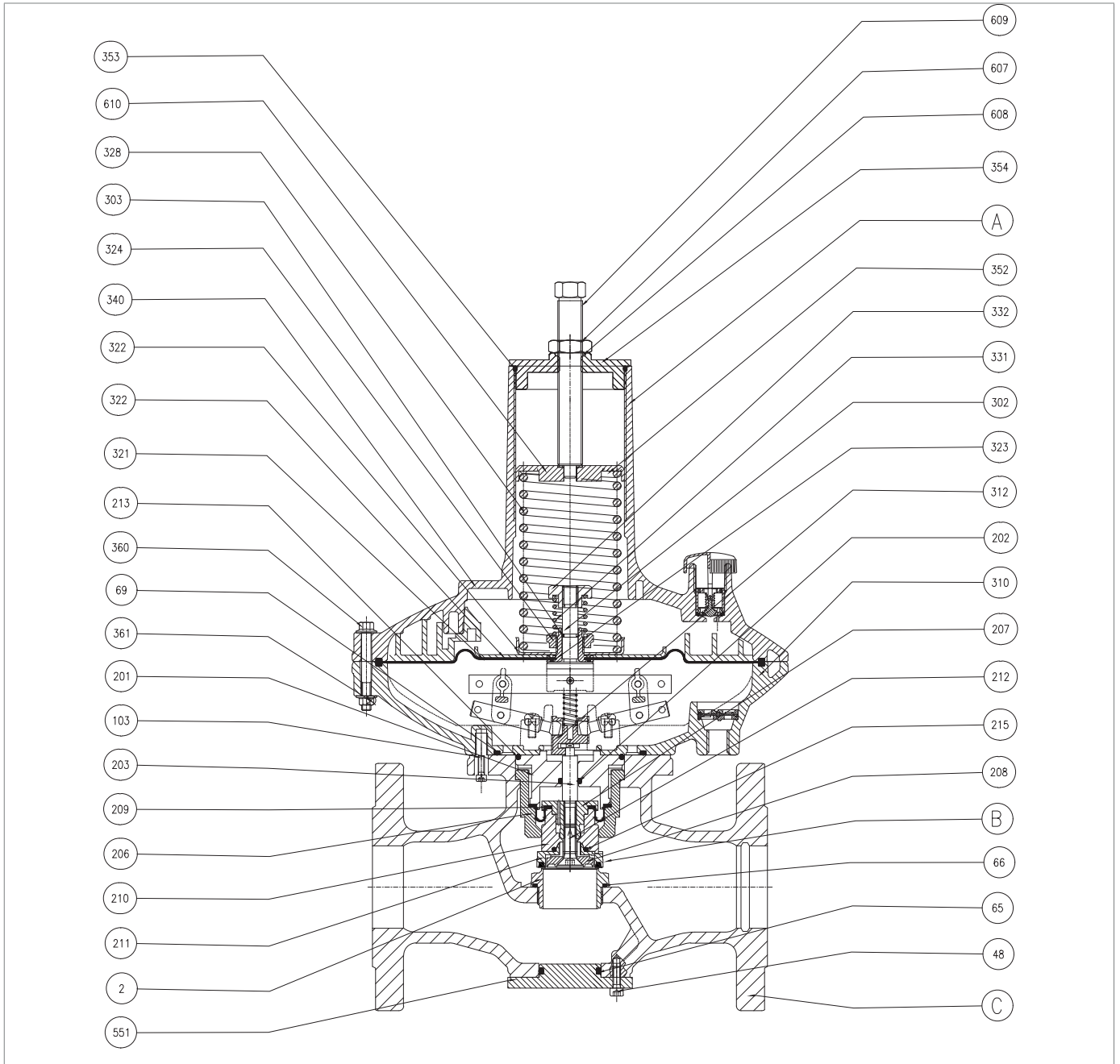
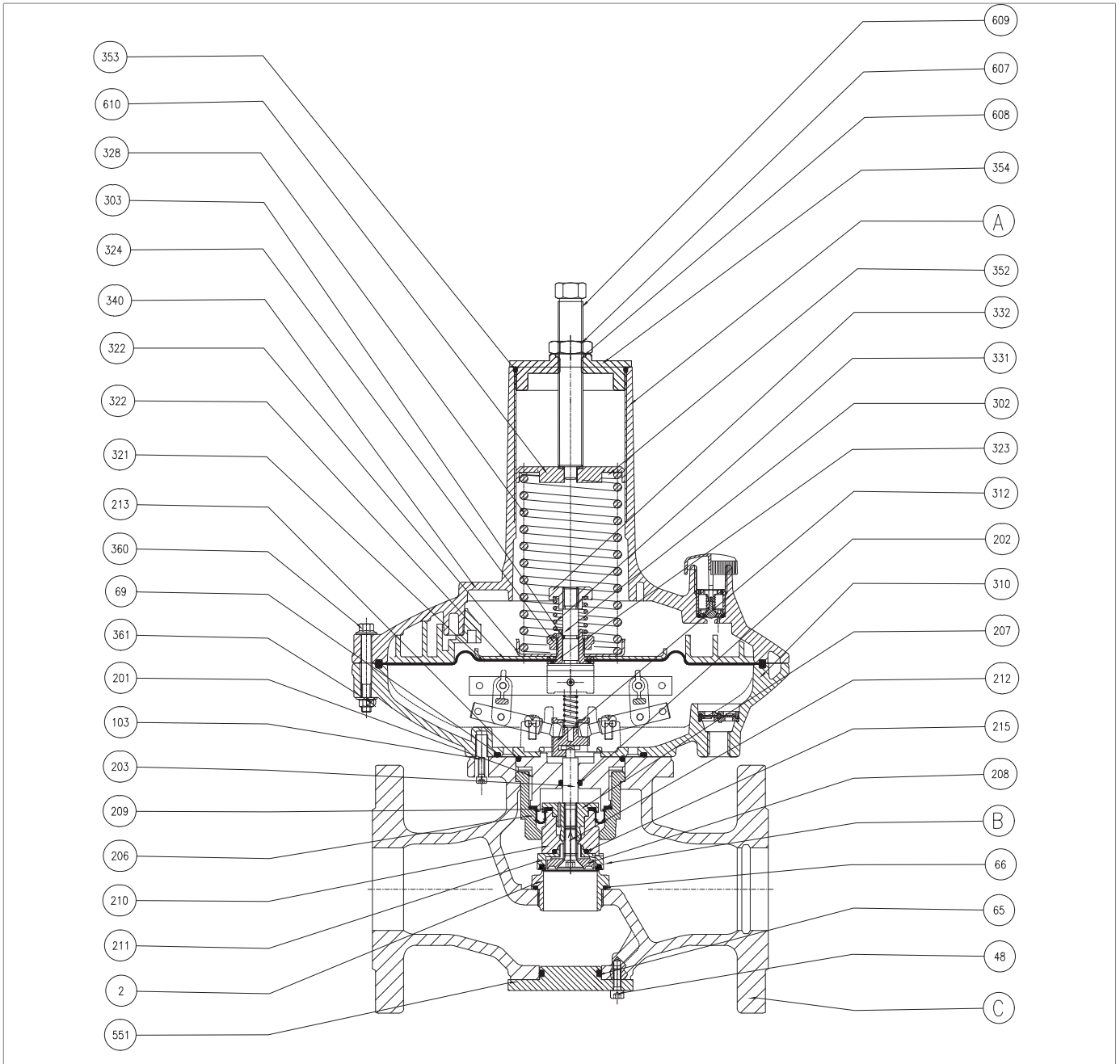

Fig. 9.31. DIVAL 600 Regulator 1" 1/2 ; 2", TR head

Step	Action
1	Unscrew and remove the adjusting screw (609) together with the locking nut (607).
2	Remove and replace the O-rings (353, 608), taking care to lubricate them with synthetic grease. NOTICE! Before inserting the replacement O-rings, clean the retaining slots with a cleaning solution.
3	Remove the spring guide disc (610) together with the washer (352).
4	Remove the regulation spring (328).
5	Unscrew and remove the screws (103) securing the control head (A) to the body (C).
6	Remove the control head (A) together with the balancing block (B).
7	Separate the balancing block (B) from the control head (A). NOTICE! Follow the indication of the arrow.
8	Unscrew and remove the nuts (361).
9	Undo and remove the screws (360).
10	Remove the upper cover (340) from the lower cover (310).
11	Unscrew and remove the locking nut (332).
12	Pull out the spring (331) of the relief valve.
13	Pull the diaphragm support assembly (321, 322, 323, 324) off the rod (302).
14	Remove the O-ring (303) and replace it, taking care to lubricate it with synthetic grease. NOTICE! Before inserting the replacement O-ring, clean the retaining slots with a cleaning solution.
15	Unscrew and remove the locking nut (324). NOTICE! During this phase, keep the diaphragm support (323) still.
16	Remove the diaphragm protection disc (322).
17	Remove and replace the main diaphragm (321).
18	Fit the diaphragm protection disc (322).
19	Insert and secure the locking nut (324), according to the tightening torques: • “Tab. 9.58” NOTICE! During this phase, keep the diaphragm support (323) still.
20	Position the diaphragm support assembly (321, 322, 323, 324, 390) in the rod (302).
21	Insert the spring (331) of the relief valve.
22	Insert and fix the nut (332) according to the following tightening torques: • “Tab. 9.58”
23	Place the upper cover (340) on the lower cover (310). NOTICE! Follow the orientation of the anti-pumping valve when positioning the cover.



DIVAL 600 Regulator 1" 1/2 ; 2", TR head

Step	Action
24	<p>Insert and fix the screws (360) together with the nuts (361) according to the following tightening torques:</p> <ul style="list-style-type: none"> • “Tab. 9.58” <p>! NOTICE!</p> <p>Screw in as shown in the diagram at “9.4.2.2 - Cross diagram for tightening screws”.</p>
25	<p>Unscrew and remove the fixing screw (211).</p> <p>! NOTICE!</p> <p>During this phase, keep the rod (203) still.</p>
26	<p>Remove the plug (208) together with the O-ring (215) and plug ring (212).</p>
27	<p>Remove the O-ring (215) and replace it, taking care to lubricate it with synthetic grease.</p> <p>! NOTICE!</p> <p>Before inserting the replacement O-ring, clean the retaining slots with a cleaning solution.</p>
28	<p>Remove the bushing (206), spacer (210) and diaphragm (209).</p>
29	<p>Remove the O-ring (213) and replace it, taking care to lubricate it with synthetic grease.</p> <p>! NOTICE!</p> <p>Before inserting the replacement O-ring, clean the retaining slots with a cleaning solution.</p>
30	<p>Unscrew the diaphragm protection disc (207).</p> <p>! NOTICE!</p> <p>During this phase, keep the rod (203) still.</p>
31	<p>Slide the rod guide (201) off the rod (203).</p>
32	<p>Remove the O-ring (202) and replace it, taking care to lubricate it with synthetic grease.</p> <p>! NOTICE!</p> <p>Before inserting the replacement O-ring, clean the retaining slots with a cleaning solution.</p>
33	<p>Insert the rod guide (201) into the rod (203).</p>
34	<p>Put the diaphragm protection disc (207) back in place.</p> <p>! NOTICE!</p> <p>During this phase, keep the rod (203) still.</p>
35	<p>Insert the diaphragm (209) onto the diaphragm protection disc (207).</p>
36	<p>Position the plug support (210) together with the O-ring (215) and the bushing (206).</p>
37	<p>Insert plug (208), plug ring (212) on spacer (210).</p>
38	<p>Insert and fix the screw (211) according to the tightening torques:</p> <ul style="list-style-type: none"> • “Tab. 9.58” <p>! NOTICE!</p> <p>When fastening, align the mechanical stop on the surface.</p>
39	<p>Unscrew and remove the valve seat (2) together with the O-ring (66).</p>
40	<p>Remove the O-ring (66) and replace it, taking care to lubricate it with synthetic grease.</p> <p>! NOTICE!</p> <p>Before inserting the replacement O-ring, clean the retaining slots with a cleaning solution.</p>

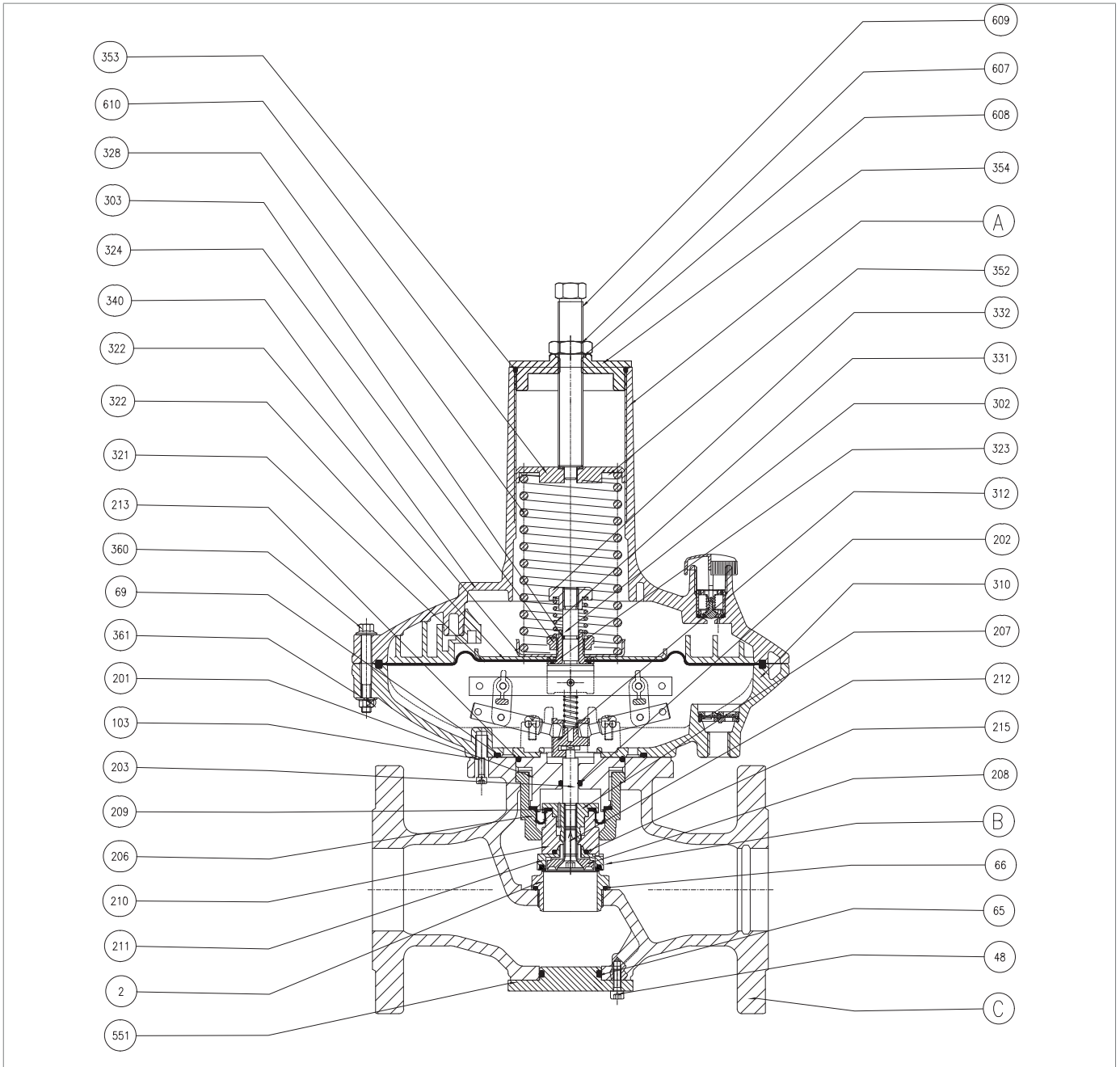

DIVAL 600 Regulator 1" 1/2 ; 2", TR head

Step	Action
41	Insert the valve seat (2) together with the O-ring (66) into the body (C) according to the tightening torques: <ul style="list-style-type: none"> • “Tab. 9.58”
42	Remove the O-ring (69) and replace it, taking care to lubricate it with synthetic grease. <div style="border: 1px solid black; padding: 5px; margin-top: 5px;"> <p>! NOTICE! Before inserting the replacement O-ring, clean the retaining slots with a cleaning solution.</p> </div>
43	Position the balancing block (B) in the control head (A). <div style="border: 1px solid black; padding: 5px; margin-top: 5px;"> <p>! NOTICE! In the opposite direction indicated by the arrow on the lower cover (310).</p> </div>
44	Position the control head (A) and the balancing block (B) in the housing (C).
45	Insert and fasten the screws (103) that secure the control head (A) to the body (C) according to the tightening torques: <ul style="list-style-type: none"> • “Tab. 9.58” <div style="border: 1px solid black; padding: 5px; margin-top: 5px;"> <p>! NOTICE! Screw in as shown in the diagram at “9.4.2.2 - Cross diagram for tightening screws”.</p> </div>
46	Insert the regulation spring (328).
47	Insert the spring guide disc (610) together with washer (352).
48	Insert and secure the cap (354) together with the O-rings (353, 608).
49	Insert the adjusting screw (609) together with the locking nut (607) into the cap (354).
50	Undo and remove the lower screws (48).
51	Remove the flange (551) together with the O-ring (65).
52	Remove the O-ring (65) and replace it, taking care to lubricate it with synthetic grease. <div style="border: 1px solid black; padding: 5px; margin-top: 5px;"> <p>! NOTICE! Before inserting the replacement O-rings, clean the retaining slots with a cleaning solution.</p> </div>
53	Position the flange (551) together with the O-ring (65).
54	Insert and fix the lower screws (48) according to the following tightening torques: <ul style="list-style-type: none"> • “Tab. 9.58” <div style="border: 1px solid black; padding: 5px; margin-top: 5px;"> <p>! NOTICE! Screw in as shown in the diagram at “9.4.2.2 - Cross diagram for tightening screws”.</p> </div>

Tab. 9.64

! WARNING!

Ensure that all parts have been fitted correctly.

9.4.4 - LA SLAM-SHUT VALVE

9.4.4.1 - LA SLAM-SHUT VALVE 1" - 2" BP/MP

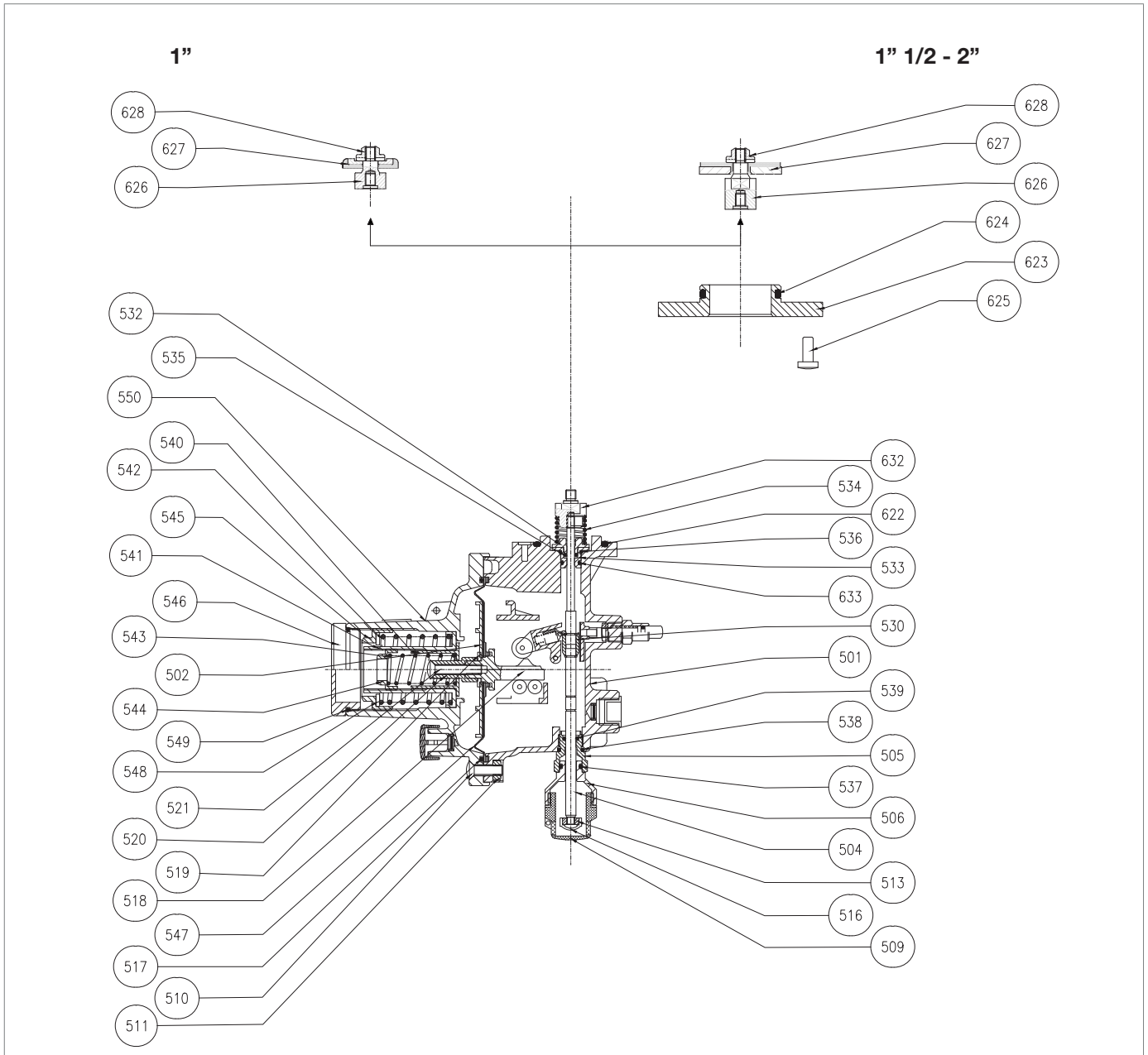







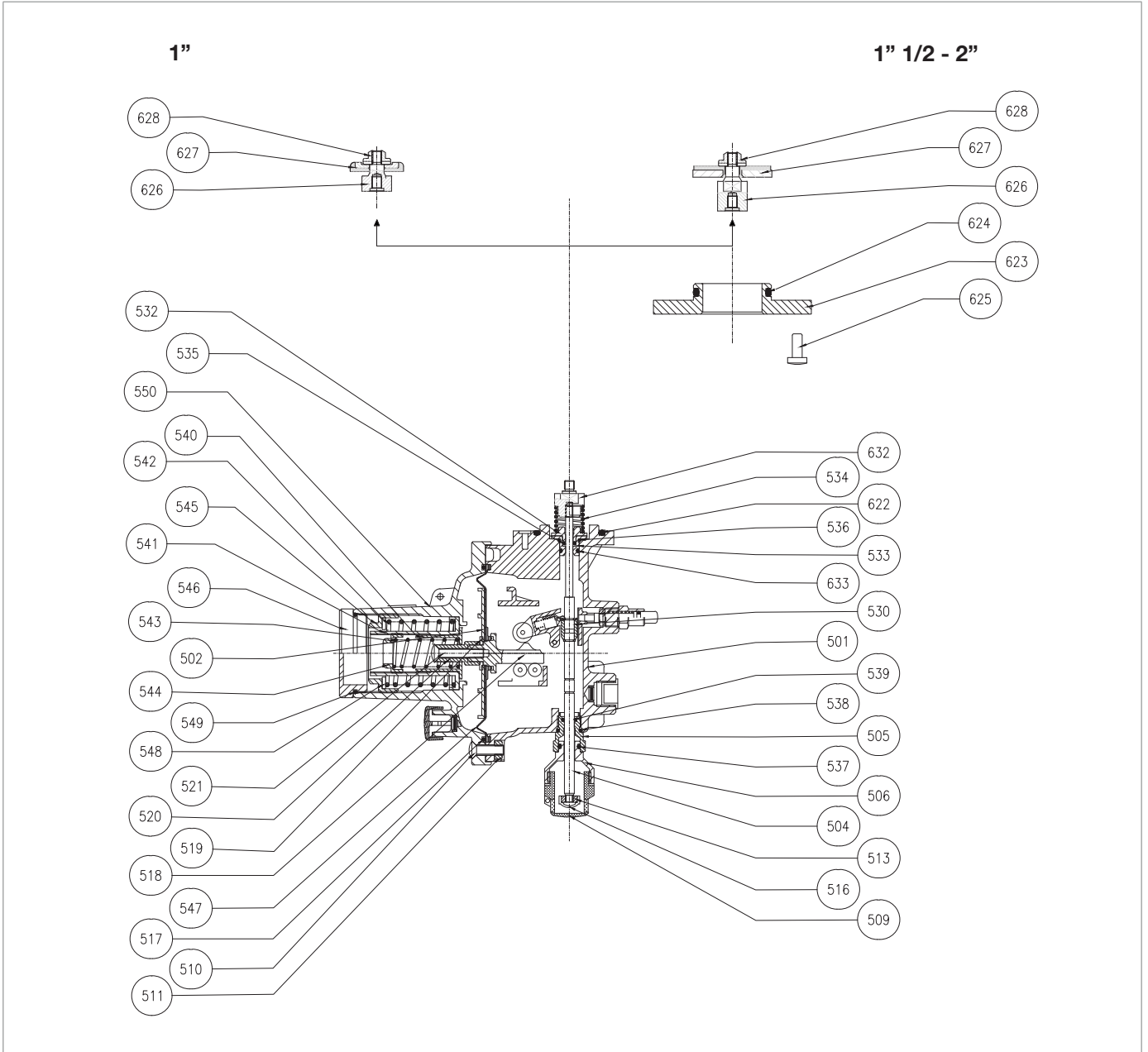

Fig. 9.32. LA slam-shut valve 1" - 2" BP/MP

Step	Action
1	 WARNING! Check that the slam-shut valve is in the closed position.
2	 ATTENTION! Before servicing, remove the LA slam-shut valve by unscrewing the screws (48) on the regulator (refer to “9.4.3 - Regulator DIVAL 600”).
3	Unscrew and remove the locking nut (628).  NOTICE! During this step, hold the spacer (626) in place.
4	Remove and replace the plug (627).
5	APPLICABLE TO SIZES 1” ½ - 2” ONLY Undo and remove the screws (625).
6	APPLICABLE TO SIZES 1” ½ - 2” ONLY Remove the flange (623).
7	APPLICABLE TO SIZES 1” ½ - 2” ONLY Remove the O-ring (624) and replace it, taking care to lubricate it with synthetic grease.  NOTICE! Before inserting the replacement O-ring, clean the retaining slots with a cleaning solution.
8	Remove the O-ring (622) and replace it, taking care to lubricate it with synthetic grease.  NOTICE! Before inserting the replacement O-ring, clean the retaining slots with a cleaning solution.
9	Unscrew and remove the cap (509).
10	Remove the cap (516).
11	Unscrew and remove the locking nut (513).
12	Remove the bushing (632).  NOTICE! During this phase, keep the rod (504) still.
13	Slide the rod (504) in the direction of the reset.
14	Pull off the knob (506).  NOTICE! During this phase, keep the rod (504) still.
15	Unscrew and remove the rod guide (505) together with the O-rings (537, 538, 539).
16	Replace the O-rings (537, 538, 539), lubricating them with synthetic grease.  NOTICE! Before inserting the replacement O-rings, clean the retaining slots with a cleaning solution.
17	Insert the rod guide (505) together with the O-rings (537, 538, 539), according to the tightening torques: <ul style="list-style-type: none"> • “Tab. 9.59”
18	Insert and secure the knob (506).
19	Remove the washer (532).
20	Remove the rod guide (533) together with O-rings (535, 536, 633).



LA slam-shut valve 1" - 2" BP/MP

Step	Action
21	Remove and replace the O-rings (535, 536, 633), taking care to lubricate them with synthetic grease. NOTICE! Before inserting the replacement O-rings, clean the retaining slots with a cleaning solution.
22	Insert the rod guide (533) together with the O-rings (535, 536, 633).
23	Fit the washer (532).
24	Insert the rod (504) in the opposite direction to the reset.
25	Place the spring (534) in the washer (532). NOTICE! During this phase, keep the rod (504) still.
26	Position and secure the bushing (632) on the rod (504).
27	Position and secure the spacer (626). NOTICE! During this step, hold the bushing (632) in place.
28	Fit the plug (627).
29	Insert and secure the locking nut (628) according to the tightening torques: • “Tab. 9.59” NOTICE! Apply threadlocker glue
30	APPLICABLE TO SIZES 1” ½ - 2” ONLY Position the flange (623) in the body (501).
31	APPLICABLE TO SIZES 1” ½ - 2” ONLY Insert and fix the screws (625) according to the following tightening torques: • “Tab. 9.59” NOTICE! Screw in as shown in the diagram at “9.4.2.2 - Cross diagram for tightening screws”.
32	Insert and secure the locking nut (513) according to the tightening torques: • “Tab. 9.59”
33	Position the cap (516).
34	Insert and fix the cap (509).
35	Unscrew the cap (546) together with the O-ring (549).
36	Remove the O-ring (549) and replace it, taking care to lubricate it with synthetic grease. NOTICE! Before inserting the replacement O-ring, clean the retaining slots with a cleaning solution.
37	Unscrew the adjustment ring nut (545).
38	Pull out the maximum spring (542).
39	Remove spring holder (541).
40	Remove the spring guide (540). NOTICE! If fitted, remove the minimum spring (543).

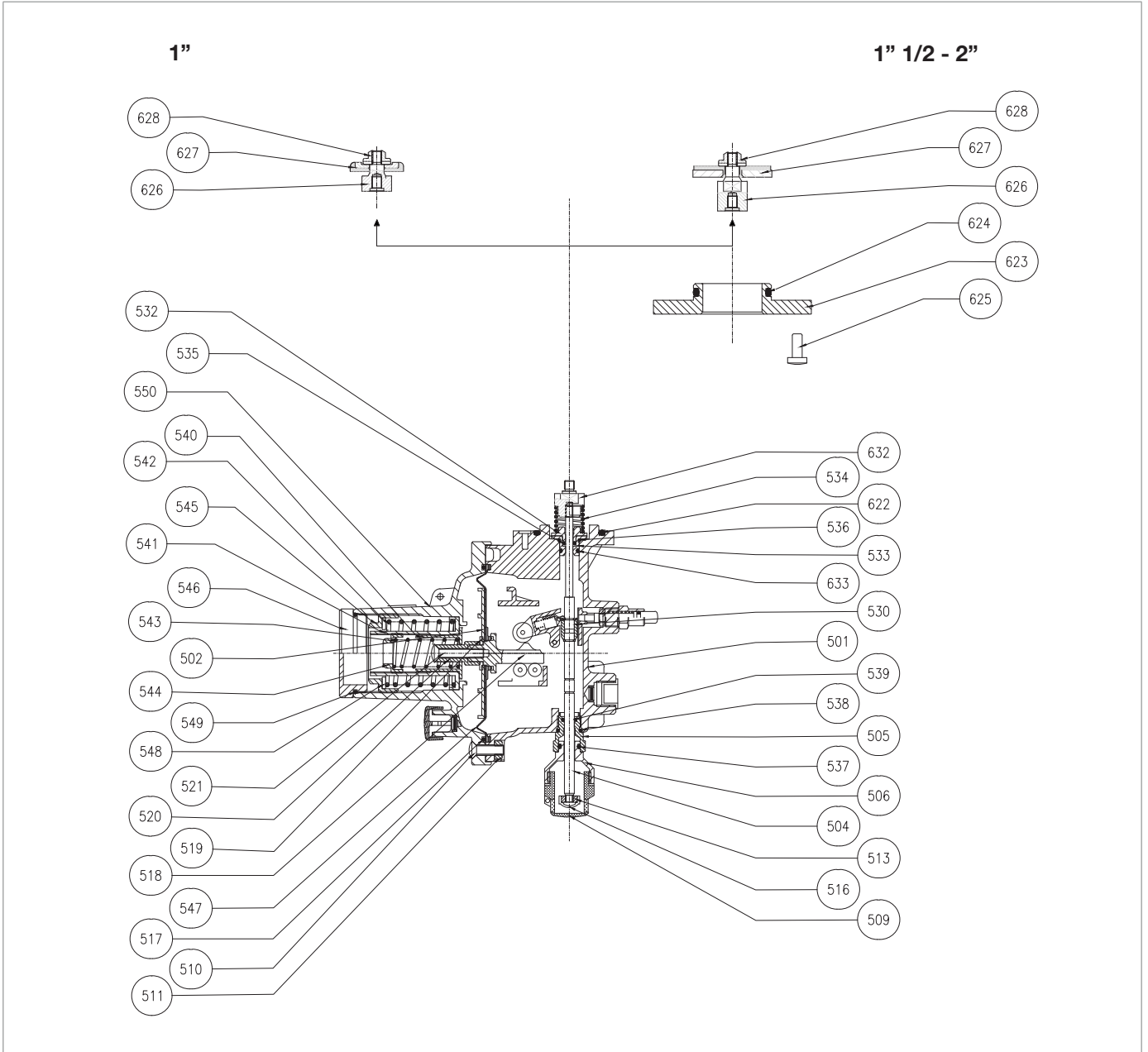

LA slam-shut valve 1" - 2" BP/MP

Step	Action
41	Unscrew and remove the screws (510) together with the nuts (511).
42	Remove the cover (550) from the body (501).
43	Remove the diaphragm assembly: diaphragm (547), diaphragm protection disc (502), washer (519), diaphragm support (518), compression bushing (520), locking screw (521).
44	Undo and remove the locking screw (521). NOTICE! During this phase, keep the diaphragm support (518) still.
45	Unscrew and remove the compression bushing (520).
46	Remove the washer (519).
47	Remove the diaphragm protection disc (502).
48	Replace the diaphragm (547).
49	Fit the diaphragm protection disc (502).
50	Position washer (519).
51	Set compression bushing (520).
52	Insert and secure the clamping screw (521) in the diaphragm holder, according to the tightening torques: • “Tab. 9.59”
53	Place diaphragm assembly.
54	Insert cover (550) into body (501).
55	Insert and fix the screws (510) together with the nuts (511) according to the tightening torques: • “Tab. 9.59” NOTICE! Screw in as shown in the diagram at “9.4.2.2 - Cross diagram for tightening screws”.
56	Insert spring guide (540).
57	Insert spring holder (541).
58	Insert the maximum spring (542).
59	Insert and fasten adjustment ring nut (545)
60	Insert and secure the cap (546) together with the O-ring (549).
61	ATTENTION! After maintenance, insert the LA slam-shut valve by fastening the screws (48) of the regulator (9.4.3), according to the tightening torques • “Tab. 9.59” NOTICE! Screw in as shown in the diagram at “9.4.2.2 - Cross diagram for tightening screws”.

Tab. 9.65

WARNING!

Ensure that all parts have been fitted correctly.

9.4.4.2 - LA SLAM-SHUT VALVE 1" - 2" TR

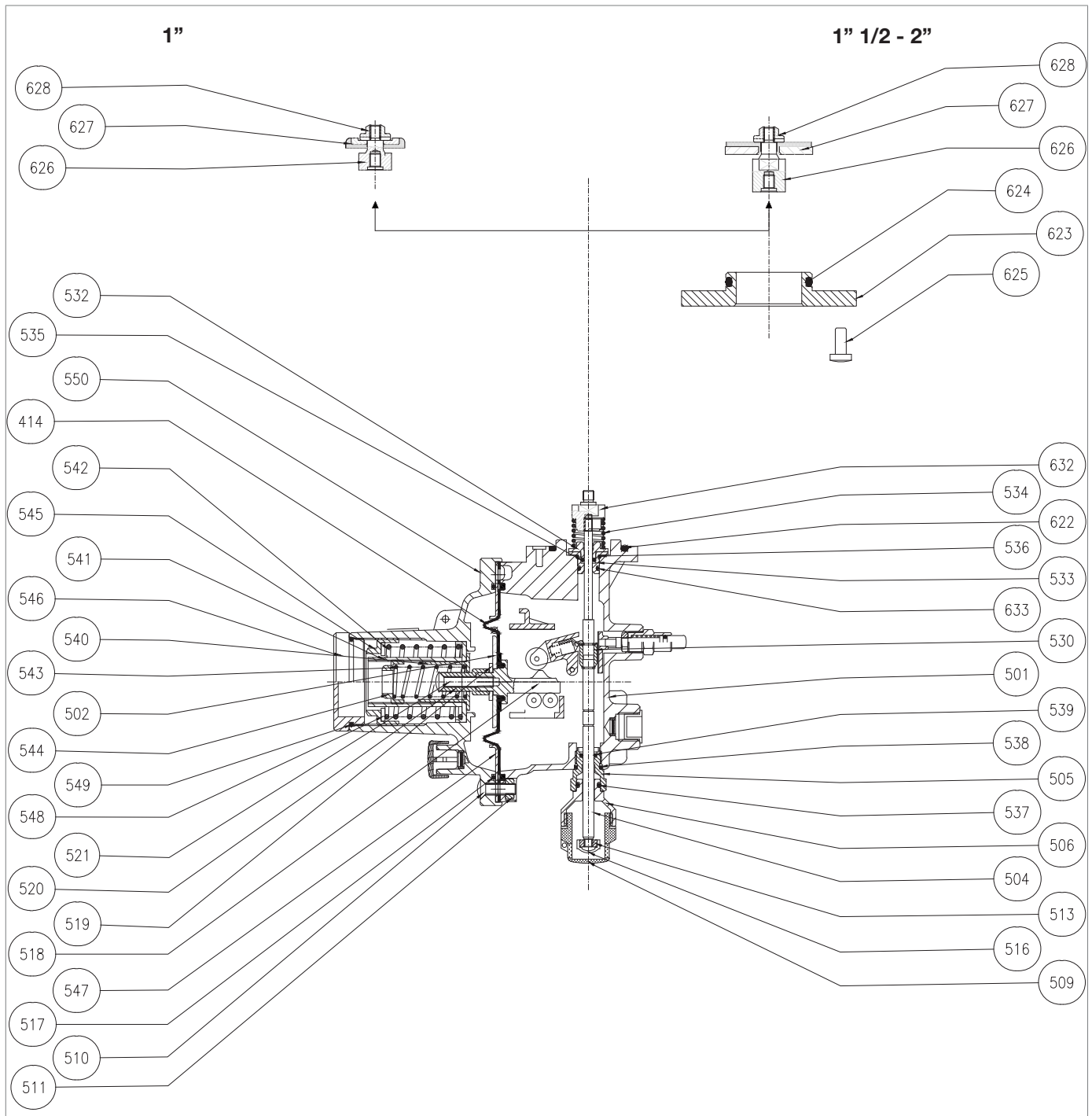







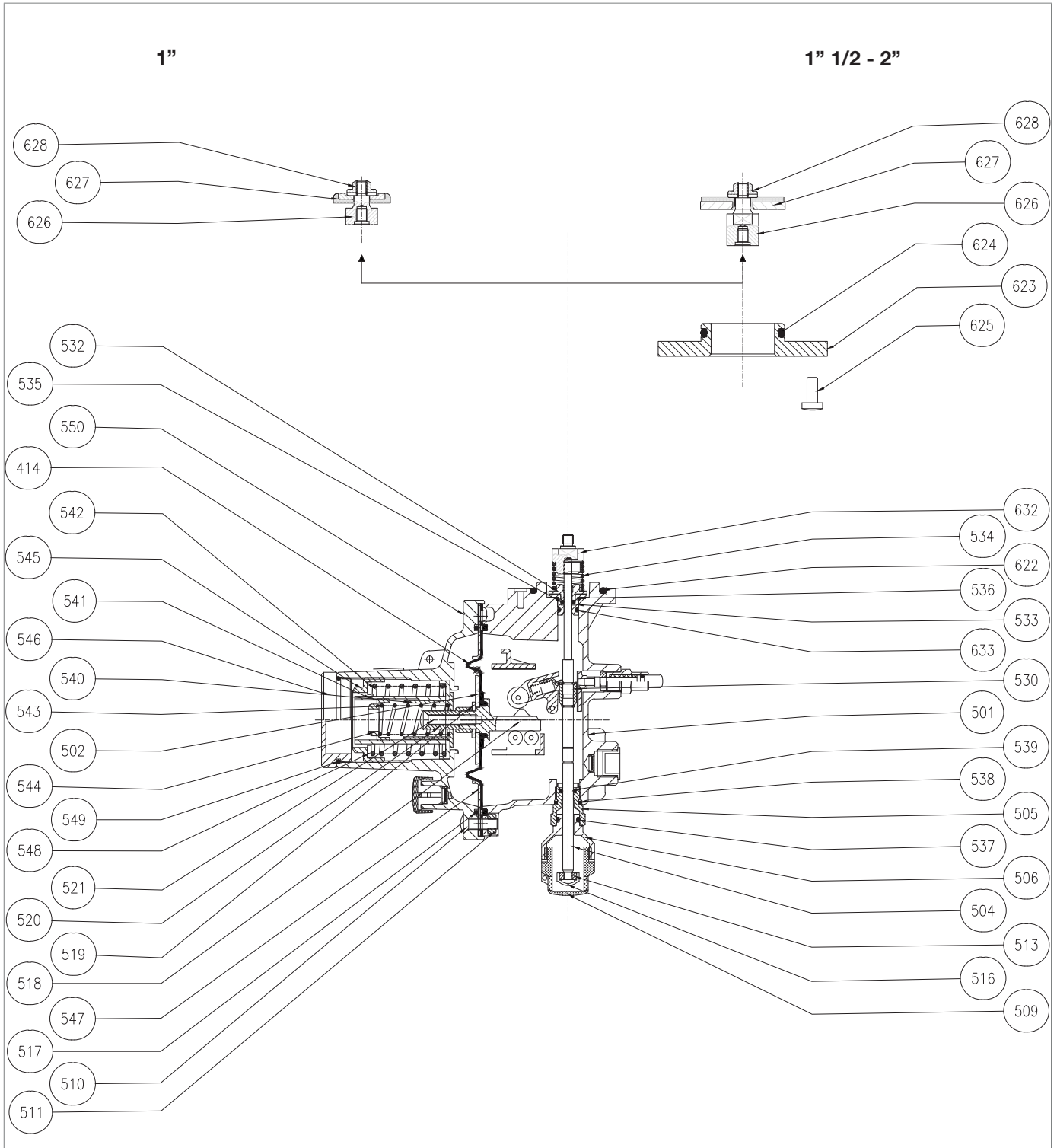

Fig. 9.33. LA slam-shut valve 1" - 2" TR

Step	Action
1	 WARNING! Check that the slam-shut valve is in the closed position.
2	 ATTENTION! Before servicing, remove the LA slam-shut valve by unscrewing the screws (48) on the regulator (refer to “9.4.3 - Regulator DIVAL 600”).
3	Unscrew and remove the locking nut (628).  NOTICE! During this step, hold the spacer (626) in place.
4	Remove and replace the plug (627).
5	APPLICABLE TO SIZES 1” ½ - 2” ONLY Undo and remove the screws (625).
6	APPLICABLE TO SIZES 1” ½ - 2” ONLY Remove the flange (623).
7	APPLICABLE TO SIZES 1” ½ - 2” ONLY Remove the O-ring (624) and replace it, taking care to lubricate it with synthetic grease.  NOTICE! Before inserting the replacement O-ring, clean the retaining slots with a cleaning solution.
8	Remove the O-ring (622) and replace it, taking care to lubricate it with synthetic grease.  NOTICE! Before inserting the replacement O-ring, clean the retaining slots with a cleaning solution.
9	Unscrew and remove the cap (509).
10	Remove the cap (516).
11	Unscrew and remove the locking nut (513).
12	Remove the bushing (632).  NOTICE! During this phase, keep the rod (504) still.
13	Slide the rod (504) in the direction of the reset.
14	Unscrew and remove the knob (506).  NOTICE! During this phase, keep the rod (504) still.
15	Unscrew and remove the rod guide (505) together with the O-rings (537, 538, 539).
16	Replace the O-rings (537, 538, 539), lubricating them with synthetic grease.  NOTICE! Before inserting the replacement O-rings, clean the retaining slots with a cleaning solution.
17	Insert rod guide (505) together with O-rings (537, 538, 539).
18	Insert and secure the knob (506).
19	Remove the washer (532).



LA slam-shut valve 1" - 2" TR

Step	Action
20	Remove the rod guide (533) together with O-rings (535, 536, 633).
21	Remove and replace the O-rings (535, 536, 633), taking care to lubricate them with synthetic grease. NOTICE! Before inserting the replacement O-rings, clean the retaining slots with a cleaning solution.
22	Insert the rod guide (533) together with the O-rings (535, 536, 633).
23	Fit the washer (532).
24	Insert the rod (504) in the opposite direction to the reset.
25	Place the spring (534) in the washer (532). NOTICE! During this phase, keep the rod (504) still.
26	Position and secure the bushing (632) on the rod (504).
27	Position and secure the spacer (626). NOTICE! During this step, hold the bushing (632) in place.
28	Fit the plug (627).
29	Insert and secure the locking nut (628) according to the tightening torques: • “Tab. 9.59” NOTICE! Apply threadlocker glue
30	APPLICABLE TO SIZES 1” ½ - 2” ONLY Position the flange (623) in the body (501).
31	APPLICABLE TO SIZES 1” ½ - 2” ONLY Insert and fix the screws (625) according to the following tightening torques: • “Tab. 9.59” NOTICE! Screw in as shown in the diagram at “9.4.2.2 - Cross diagram for tightening screws”.
32	Insert and secure the locking nut (513) according to the tightening torques: • “Tab. 9.59”
33	Position the cap (516).
34	Insert and fix the cap (509).
35	Unscrew the cap (546) together with the O-ring (549).
36	Remove the O-ring (549) and replace it, taking care to lubricate it with synthetic grease. NOTICE! Before inserting the replacement O-ring, clean the retaining slots with a cleaning solution.
37	Unscrew the adjustment ring nut (545).
38	Pull out the maximum spring (542).
39	Remove spring holder (541).
40	Remove the spring guide (540). NOTICE! If fitted, remove the minimum spring (543).

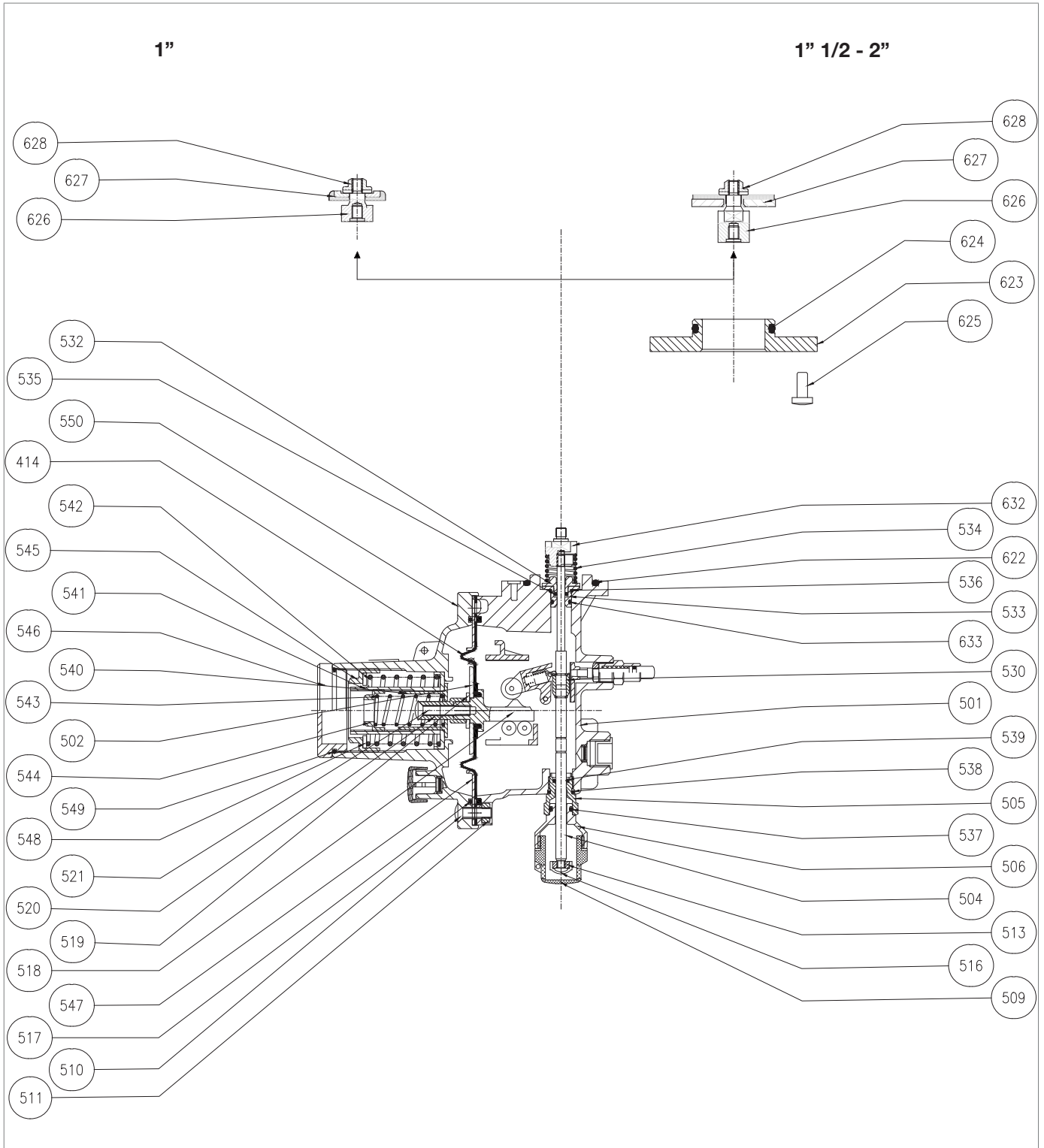

LA slam-shut valve 1" - 2" TR

Step	Action
41	Unscrew and remove the screws (510) together with the nuts (511).
42	Remove the cover (550) from the body (501).
43	Remove the diaphragm assembly: diaphragm (547), diaphragm protection disc (502), washer (519), diaphragm support (518), compression bushing (520), locking screw (521).
44	Undo and remove the locking screw (521). NOTICE! During this phase, keep the diaphragm support (518) still.
45	Unscrew and remove the compression bushing (520).
46	Remove the washer (519).
47	Remove the diaphragm protection disc (502).
48	Replace the diaphragm (547).
49	Fit the diaphragm protection disc (502).
50	Position washer (519).
51	Set compression bushing (520).
52	Insert and secure the clamping screw (521) in the diaphragm holder, according to the tightening torques: • “Tab. 9.59”
53	Place diaphragm assembly.
54	Insert cover (550) into body (501).
55	Insert and fix the screws (510) together with the nuts (511) according to the tightening torques: • “Tab. 9.59”
56	Insert spring guide (540).
57	Insert spring holder (541).
58	Insert the maximum spring (542).
59	Insert and fasten adjustment ring nut (545)
60	Insert and secure the cap (546) together with the O-ring (549).
61	ATTENTION! After maintenance, insert the LA slam-shut valve by fastening the screws (48) of the regulator (9.4.3), according to the tightening torques • “Tab. 9.59” NOTICE! Screw in as shown in the diagram at “9.4.2.2 - Cross diagram for tightening screws”.

Tab. 9.66

WARNING!

Ensure that all parts have been fitted correctly.

9.4.5 - PROCEDURE FOR RECOMMISSIONING AFTER MAINTENANCE

 **NOTICE!**

For the re-commissioning procedure, please follow the instructions in section “8.5 - Regulator commissioning procedure”

10 - TROUBLESHOOTING

Listed below are the cases (causes and tripping) that could occur in the form of malfunctions of various kinds over time. These situations depend on the conditions of the gas as well as on the natural ageing and wear of the materials.

10.1 - GENERAL WARNINGS

HAZARD!

Maintenance work must be carried out by qualified personnel:

- trained on workplace safety also based on the regulations in force in the place of installation of the work equipment;
- qualified and authorised to carry out activities related to the equipment.

WARNING!





PIETRO FIORENTINI S.p.A. shall not be held liable for any damage to people and property due to services:

- other than those described;
- performed according to methods other than those specified;
- carried out by unsuitable personnel.

NOTICE!

If an operating fault occurs and qualified personnel are not available for the specific service, call the PIETRO FIORENTINI S.p.A. Authorised Assistance Centre

10.2 - OPERATOR QUALIFICATION SPECIFICATION

Commissioning	
Operator qualification	<ul style="list-style-type: none"> • Mechanical maintenance technician; • Electrical maintenance technician; • Installer; • User's technician.
PPE required	<div style="display: flex; align-items: center; gap: 5px;">      </div> <div style="background-color: #f4a460; padding: 5px; margin-top: 5px;"> <p>⚠ WARNING!</p> <p>The PPE listed in this table is related to the risk associated with the equipment. For the PPE required to protect against risks associated with the workplace, installation or operating conditions, please refer to:</p> <ul style="list-style-type: none"> • the regulations in force in the country of installation; • <u>any information provided by the Safety Manager at the installation facility.</u> </div>
Equipment required	Please refer to the chapter "7 - Commissioning/maintenance equipment".

Tab. 10.67

10.3 - TROUBLESHOOTING PROCEDURES

For proper troubleshooting, proceed as follows:

- close the upstream and downstream shut-off valves;
- refer to the troubleshooting tables listed below.

10.4 - TROUBLESHOOTING TABLES

NOTICE!

See chapter “9 - Maintenance and functional checks” for pictures of the regulator DIVAL 600 and its accessories.

10.4.1 - TROUBLESHOOTING DIVAL 600 REGULATOR

Failure	Possible causes	Intervention
No sealing or zero flow rate	Valve seat (2) damaged	Replace
	Plug (211) damaged	Replace
	O-ring (202) damaged	Replace
	O-ring (213) damaged	Replace
	O-ring (215) damaged	Replace
	Diaphragm (209) damaged	Replace
	Dirt or presence of foreign bodies in the sealing area	Clean
Pumping	Plug rod assembly friction	Clean and replace if needed
	Blocked anti-pumping valves	Clean and replace if needed
	Reduced downstream volumes	Increase the volume
Downstream pressure increases on delivery	Broken or damaged diaphragm (321)	Replace
	Broken or damaged diaphragm (209)	Replace

Tab. 10.68

10.4.2 - LA SLAM-SHUT VALVE TROUBLESHOOTING

Failure	Possible causes	Intervention
Slam-shut valve failed to trip	Rod (501) locked in opening	Clean and reposition if needed
External leak	Broken diaphragm (517)	Replace
Downstream pressure (Pd) increases in open valve position	O-ring (521) not sealing	Replace
	O-ring (523) not sealing	Replace
	Rod (501) damaged	Replace
Downstream pressure (Pd) increases in closed valve position	O-ring (521) not sealing	Replace
	Rod (501) damaged	Replace
	Reinforced gasket (528) damaged	Replace
	Valve seat (102) damaged	Replace
	Damaged valve seat O-ring (104)	Replace
Slam-shut valve failed to trip due to pressure increase	Broken diaphragm (517)	Replace
Slam-shut valve failed to trip due to pressure decrease	Broken diaphragm (517)	Replace

Tab. 10.69

11 - UNINSTALLATION AND DISPOSAL

11.1 - GENERAL SAFETY WARNINGS

HAZARD!



Make sure that there are no potentially explosive ignition sources in the work area set up to uninstall and/or dispose of the equipment.

WARNING!

Before proceeding with uninstallation and disposal, make the equipment safe by disconnecting it from any power supply.

11.2 - QUALIFICATION OF THE OPERATORS IN CHARGE

Commissioning

Operator qualification	Installer
PPE required	 <p> WARNING!</p> <p>The PPE listed in this table is related to the risk associated with the equipment. For the PPE required to protect against risks associated with the workplace, installation or operating conditions, please refer to:</p> <ul style="list-style-type: none"> • the regulations in force in the country of installation; • any information provided by the Safety Manager at the installation facility.
Equipment required	Please refer to the chapter “7 - Commissioning/maintenance equipment”.

Tab. 11.70

11.3 - UNINSTALLATION

ATTENTION!

Before uninstalling the equipment, completely drain the fluid in the reduction line and inside the equipment.

NOTICE!

For equipment uninstallation procedures, please refer to the installation procedures (see chapter “6 - installation”), proceeding in reverse order.

11.4 - INFORMATION REQUIRED IN CASE OF RE-INSTALLATION

NOTICE!

Should the equipment be reused after uninstallation, refer to chapters:

- “6 - installation”;
- “8 - Commissioning”.

11.5 - DISPOSAL INFORMATION

NOTICE!

Bear in mind that the laws in force in the country of installation must be complied with. Illegal or improper disposal involves the application of the penalties provided for by the legislation in force in the country of installation.

NOTICE!

Proper disposal prevents damage to humans and the environment and promotes the reuse of precious raw materials.

The equipment was manufactured with materials that can be recycled by specialised companies. For proper disposal of the equipment, proceed as specified in “Tab. 11.71”:

Step	Action
1	Set up a large work area free from obstacles where to safely dismantle the equipment.
2	Sort the various components by type of material for easier recycling through separate collection.
3	Send the materials obtained in Step 2 to a specialised company.

Tab. 11.71

The equipment in any configuration consists of the following materials:

Material	Disposal/recycling indications
Plastic	It must be dismantled and disposed of separately.
Lubricants/Oils	They must be collected and delivered to the appropriate specialised and authorised collection and disposal centres.
Steel/Cast Iron	Disassemble and collect separately. It must be recycled through the specific collection centres.
Stainless steel	Disassemble and collect separately. It must be recycled through the specific collection centres.
Aluminium	Disassemble and collect separately. It must be recycled through the specific collection centres.
Pneumatic/electric components	They must be dismantled in order to be reused if they are still in good condition or, if possible, overhauled and recycled.

Tab. 11.72

NOTICE!

Please refer to the chapter “9 - Maintenance and functional checks” to better identify the composition of the equipment and its parts.

12 - RECOMMENDED SPARE PARTS

12.1 - GENERAL WARNINGS

 **NOTICE!**

If non-original spare parts are used, PIETRO FIORENTINI S.p.A. their declared performance cannot be guaranteed.

It is recommended to use PIETRO FIORENTINI S.p.A. original spare parts

PIETRO FIORENTINI S.p.A. shall not be held liable for any damage caused by using non-original parts.

12.2 - HOW TO REQUEST SPARE PARTS

 **NOTICE!**

For specific information, please refer to the sales network of PIETRO FIORENTINI S.p.A.

13 - CALIBRATION TABLES

13.1 - CALIBRATION TABLES DIVAL 600 REGULATOR

DIVAL 600 BP 1" DN 25							
Pos.	Spring item code	Spring colour	d	Lo	De	Min.	Max.
1	2701345	Yellow	3.5	180	65	0.012	0.017
	2700525	Orange	2	40	22		
2	2701620	Orange	4	180	65	0.018	0.028
	2700525	Orange	2	40	22		
3	2701860	Red	4.5	180	65	0.029	0.045
	2700525	Orange	2	40	22		
4	2702190	Green	5	180	65	0.046	0.07
	2700645	Red	2.3	40	22		
5	2702370	Black	5.5	180	65	0.071	0.115
	2700645	Red	2.3	40	22		
6	2702540	Blue	6	180	65	0.116	0.165
	2700645	Red	2.3	40	22		
7	2702730	Sky blue	6.5	180	65	0.166	0.26
	2700645	Red	2.3	40	22		
8	2702950	Brown	7	180	65	0.261	0.34
	2700645	Red	2.3	40	22		

d = Wire Diameter (mm) **Lo** = Spring Length (mm) **De** = External Diameter (mm) **Min./Max.** = pressure (bar)

Tab. 13.73

DIVAL 600 BP 1" DN 25 (INVERTED)							
Pos.	Spring item code	Spring colour	d	Lo	De	Min.	Max.
1	2701345	Yellow	3.5	180	65	0.009	0.013
	2700525	Orange	2	40	22		
2	2701620	Orange	4	180	65	0.014	0.024
	2700525	Orange	2	40	22		
3	2701860	Red	4.5	180	65	0.025	0.041
	2700525	Orange	2	40	22		
4	2702190	Green	5	180	65	0.042	0.065
	2700645	Red	2.3	40	22		
5	2702370	Black	5.5	180	65	0.066	0.11
	2700645	Red	2.3	40	22		
6	2702540	Blue	6	180	65	0.111	0.165
	2700645	Red	2.3	40	22		
7	2702730	Sky blue	6.5	180	65	0.166	0.26
	2700645	Red	2.3	40	22		
8	2702950	Brown	7	180	65	0.261	0.34
	2700645	Red	2.3	40	22		

d = Wire Diameter (mm) **Lo** = Spring Length (mm) **De** = External Diameter (mm) **Min./Max.** = pressure (bar)

Tab. 13.74

DIVAL 600 BP | 1" ½ ; 2" | DN 40; 50

Pos.	Spring item code	Spring colour	d	Lo	De	Min.	Max.
1	2701345	Yellow	3.5	180	65	0.012	0.017
	2700525	Orange	2	40	22		
2	2701620	Orange	4	180	65	0.018	0.028
	2700525	Orange	2	40	22		
3	2701860	Red	4.5	180	65	0.029	0.045
	2700525	Orange	2	40	22		
4	2702190	Green	5	180	65	0.046	0.07
	2700645	Red	2.3	40	22		
5	2702370	Black	5.5	180	65	0.071	0.085
	2700645	Red	2.3	40	22		

d = Wire Diameter (mm) **Lo** = Spring Length (mm) **De** = External Diameter (mm) **Min./Max.** = pressure (bar)

Tab. 13.75

DIVAL 600 BP | 1" ½; 2" | DN 40; 50 (INVERTED)

Pos.	Spring item code	Spring colour	d	Lo	De	Min.	Max.
1	2701345	Yellow	3.5	180	65	0.009	0.015
	2700525	Orange	2	40	22		
2	2701620	Orange	4	180	65	0.014	0.024
	2700525	Orange	2	40	22		
3	2701860	Red	4.5	180	65	0.025	0.041
	2700525	Orange	2	40	22		
4	2702190	Green	5	180	65	0.042	0.065
	2700645	Red	2.3	40	22		
5	2702370	Black	5.5	180	65	0.066	0.085
	2700645	Red	2.3	40	22		

d = Wire Diameter (mm) **Lo** = Spring Length (mm) **De** = External Diameter (mm) **Min./Max.** = pressure (bar)

Tab. 13.76

DIVAL 600 MP | 1" ½; 2" | DN 40; 50

Pos.	Spring item code	Spring colour	d	Lo	De	Min.	Max.
1	2702370	Black	5.5	180	65	0.8	0.11
	2700645	Red	2.3	40	22		
2	2702540	Blue	6	180	65	0.116	0.165
	2700645	Red	2.3	40	22		
3	2702730	Sky blue	6.5	180	65	0.166	0.26
	2700645	Red	2.3	40	22		
4	2702950	Brown	7	180	65	0.261	0.34
	2700645	Red	2.3	40	22		

d = Wire Diameter (mm) **Lo** = Spring Length (mm) **De** = External Diameter (mm) **Min./Max.** = pressure (bar)

Tab. 13.77

DIVAL 600 MP | 1" ½; 2" | DN 40; 50 (INVERTED)

Pos.	Spring item code	Spring colour	d	Lo	De	Min.	Max.
1	2702370	Black	5.5	180	65	0.08	0.11
	2700645	Red	2.3	40	22		
2	2702540	Blue	6	180	65	0.111	0.165
	2700645	Red	2.3	40	22		
3	2702730	Sky blue	6.5	180	65	0.166	0.26
	2700645	Red	2.3	40	22		
4	2702950	Brown	7	180	65	0.261	0.314
	2700645	Red	2.3	40	22		

d = Wire Diameter (mm) **Lo** = Spring Length (mm) **De** = External Diameter (mm) **Min./Max.** = pressure (bar)

Tab. 13.78

DIVAL 600 TR | 1" ; 1" ½ ; 2" | DN 25; 40; 50

Pos.	Spring item code	Spring colour	d	Lo	De	Min.	Max.
1	2702940	Sky blue	7	150	65	0.3	0.65
	2700999		3	37	22		
2	2703125	White/yellow	7.5	150	65	0.651	0.92
	2700999		3	37	22		
3	2703325	White/orange	8	150	65	0.921	1.15
	2700999		3	37	22		
4	2703685	White/Green	9	150	65	1.151	2.2
	2700999		3	37	22		
5	2704180	White/Black	10.5	147	65	2.201	4.2
	2700999		3	37	22		

d = Wire Diameter (mm) **Lo** = Spring Length (mm) **De** = External Diameter (mm) **Min./Max.** = pressure (bar)

Tab. 13.79

DIVAL 600 TR | 1" ; 1" ½; 2" | DN 25; 40; 50 (INVERTED)

Pos.	Spring item code	Spring colour	d	Lo	De	Min.	Max.
1	2702940	Sky blue	7	150	65	0.3	0.65
	2700999		3	37	22		
2	2703125	White/yellow	7.5	150	65	0.651	0.92
	2700999		3	37	22		
3	2703325	White/orange	8	150	65	0.921	1.15
	2700999		3	37	22		
4	2703685	White/Green	9	150	65	1.151	2.2
	2700999		3	37	22		
5	2704180	White/Black	10.5	147	65	2.201	4.2
	2700999		3	37	22		

d = Wire Diameter (mm) **Lo** = Spring Length (mm) **De** = External Diameter (mm) **Min./Max.** = pressure (bar)

Tab. 13.80

13.2 - CALIBRATION TABLE FOR SLAM-SHUT VALVE

LA/BP "Max pressure"							
Pos.	Spring item code	Spring colour	d	Lo	De	Min.	Max.
1	64470112	Red	2.2	44	34	0.03	0.049
2	64470115	Grey	2.8	42	34	0.05	0.18

d = Wire Diameter (mm) **Lo** = Spring Length (mm) **De** = External Diameter (mm) **Min./Max.** = pressure (bar)

Tab. 13.81

LA/BP "Min pressure"							
Pos.	Spring item code	Spring colour	d	Lo	De	Min.	Max.
1	64470024	White	1.3	45	15	0.006	0.06

d = Wire Diameter (mm) **Lo** = Spring Length (mm) **De** = External Diameter (mm) **Min./Max.** = pressure (bar)

Tab. 13.82

LA/MP "Max pressure"							
Pos.	Spring item code	Spring colour	d	Lo	De	Min.	Max.
1	64470115	Grey	2.8	42	34	0.14	0.179
2	64470116	Yellow	3.2	40	34	0.18	0.279
3	64470051	White	3.2	50	34	0.28	0.45

d = Wire Diameter (mm) **Lo** = Spring Length (mm) **De** = External Diameter (mm) **Min./Max.** = pressure (bar)

Tab. 13.83

LA/MP "Min pressure"							
Pos.	Spring item code	Spring colour	d	Lo	De	Min.	Max.
1	64470024	White	1.3	45	15	0.01	0.059
2	64470038	Yellow	2	40	15	0.06	0.24

d = Wire Diameter (mm) **Lo** = Spring Length (mm) **De** = External Diameter (mm) **Min./Max.** = pressure (bar)

Tab. 13.84

LA/TR "Max pressure"							
Pos.	Spring item code	Spring colour	d	Lo	De	Min.	Max.
1	64470116	Yellow	3.2	40	34	0.25	0.549
2	64470051	White	3.2	50	34	0.55	0.849
3	64470057	Blue	3.5	50	34	0.85	1.399
4	64470058	Orange	4	50	34	1.4	2.499
5	64470059	Light blue	4.5	50	34	2.5	3.999
6	64470060	Black	5	48	34	4	5.5

d = Wire Diameter (mm) **Lo** = Spring Length (mm) **De** = External Diameter (mm) **Min./Max.** = pressure (bar)

Tab. 13.85

LA/TR "Min pressure"							
Pos.	Spring item code	Spring colour	d	Lo	De	Min.	Max.
1	64470038	Yellow	2	40	34	0.1	0.499
2	64470045	Brown	2.4	41	34	0.5	0.999
3	64470046	Blue	3	40	34	1	1.999
4	64470149	Black	3.2	43	34	2	3.5

d = Wire Diameter (mm) **Lo** = Spring Length (mm) **De** = External Diameter (mm) **Min./Max.** = pressure (bar)

Tab. 13.86

LA/BP (LP) "Max pressure"							
Pos.	Spring item code	Spring colour	d	Lo	De	Min.	Max.
1	64470112	Red	2.2	44	34	0.02	0.49
2	64470115	Grey	2.8	42	34	0.05	0.18

d = Wire Diameter (mm) **Lo** = Spring Length (mm) **De** = External Diameter (mm) **Min./Max.** = pressure (bar)

Tab. 13.87

LA/BP (LP) "Min pressure"							
Pos.	Spring item code	Spring colour	d	Lo	De	Min.	Max.
1	64470024	White	1.3	45	15	0.006	0.06

d = Wire Diameter (mm) **Lo** = Spring Length (mm) **De** = External Diameter (mm) **Min./Max.** = pressure (bar)

Tab. 13.88

TM0023ENG

